

PIO-DA16/DA8/DA4

User's Manual

Warranty

All products manufactured by ICP DAS are warranted against defective materials for a period of one year from the date of delivery to the original purchaser.

Warning

ICP DAS assume no liability for damages consequent to the use of this product. ICP DAS reserves the right to change this manual at any time without notice. The information furnished by ICP DAS is believed to be accurate and reliable. However, no responsibility is assumed by ICP DAS for its use, nor for any infringements of patents or other rights of third parties resulting from its use.

Copyright

Copyright 1999 by ICP DAS. All rights are reserved.

Trademark

The names used for identification only maybe registered trademarks of their respective companies.

Tables of Contents

1. INTRODUCTION.....	4
1.1 FEATURES.....	4
1.2 SPECIFICATIONS.....	5
1.3 ORDER DESCRIPTION.....	6
1.3.1 Options.....	6
1.4 PCI DATA ACQUISITION FAMILY.....	6
1.5 PRODUCT CHECK LIST.....	7
2. HARDWARE CONFIGURATION.....	8
2.1 BOARD LAYOUT.....	8
2.2 COUNTER ARCHITECTURE.....	9
2.3 INTERRUPT OPERATION.....	10
2.3.1 Interrupt Block Diagram of PIO-DA16/8/4.....	11
2.3.2 INT_CHAN_0/1.....	12
2.3.3 Initial_high, active_low Interrupt source.....	13
2.3.4 Initial_low, active_high Interrupt source.....	14
2.3.5 Multiple Interrupt Source.....	15
2.4 D/I/O BLOCK DIAGRAM.....	17
2.4.1 DI Port Architecture (CON2).....	18
2.4.2 DO Port Architecture (CON1).....	19
2.5 D/A ARCHITECTURE.....	20
2.6 D/A CONVERT OPERATION.....	21
2.6.1 Output Range and Resolution.....	23
2.6.2 The $\pm 10V$ Voltage Output.....	24
2.6.3 The $\pm 5V$ Voltage Output.....	24
2.6.4 The 0~10V Voltage Output.....	24
2.6.5 The 0~5V Voltage Output.....	24
2.6.6 The 0~20mA Current Output.....	25
2.6.7 The 4~20mA Current Output.....	25
2.6.8 No VR & No Jumper Design.....	26
2.6.9 Factory Software Calibration.....	27
2.6.10 User Software Calibration.....	28
2.6.10 Voltage Output Connection.....	29
2.6.11 Current Output Connection.....	29
2.7 THE CONNECTORS.....	30
2.8 DAUGHTER BOARDS.....	32
2.8.1 DB-37.....	32

2.8.2	<i>DN-37</i>	32
2.8.3	<i>DB-8125</i>	32
2.8.4	<i>DB-16P Isolated Input Board</i>	33
2.8.5	<i>DB-16R Relay Board</i>	34
2.8.6.	<i>DB-24PR, DB-24POR, DB-24C</i>	35
2.8.7.	<i>Daughter Board Comparison Table</i>	36
3.	I/O CONTROL REGISTER	37
3.1	HOW TO FIND THE I/O ADDRESS.....	37
3.1.1	<i>PIO_DriverInit</i>	38
3.1.2	<i>PIO_GetConfigAddressSpace</i>	39
3.1.3	<i>Show_PIO_PISO</i>	40
3.2	THE ASSIGNMENT OF I/O ADDRESS.....	42
3.3	THE I/O ADDRESS MAP.....	43
3.3.1.	<i>RESET\ Control Register</i>	44
3.3.2	<i>AUX Control Register</i>	44
3.3.3	<i>AUX data Register</i>	45
3.3.4	<i>INT Mask Control Register</i>	45
3.3.5	<i>Aux Status Register</i>	46
3.3.6	<i>Interrupt Polarity Control Register</i>	46
3.3.7	<i>Digital Input</i>	47
3.3.8	<i>Digital Output</i>	47
3.3.9	<i>Read/Write 8254</i>	48
3.3.10	<i>D/A Select</i>	49
3.3.11	<i>D/A Data Output</i>	50
4.	DEMO PROGRAM	51
4.1	<i>PIO_PISO</i>	53
4.1.1	<i>PIO_PISO.EXE for Windows</i>	54
4.2	<i>DEMO1</i>	55
4.3	<i>DEMO2</i>	55
4.4	<i>DEMO3</i>	57
4.5	<i>DEMO5</i>	59
4.6	<i>DEMO8</i>	61
4.7	<i>DEMO9</i>	62

1. INTRODUCTION

The PIO-DA16, PIO-DA8 and PIO-DA4 are multi-channel D/A boards for the PCI bus for IBM or compatible PC.

The PIO-DA16/8/4 offer 16/8/4 channels double-buffered analog output. The output range may be configured in different ranges: $\pm 10V$, $\pm 5V$, $0\sim 10V$, $0\sim 5V$ voltage output or $4\sim 20mA$, $0\sim 20mA$ current loop sink.

The innovative design improves several drawbacks of the conventional D/A boards. For examples: 1. Jumperless and without trim-pot. 2. The calibration is performed under software control eliminating manual trim-pot adjustments. The calibration data is stored in EEPROM. 3. Each channel can be selected as voltage or current output. 4. High channel count output can be implemented in half size.

Note: This card need $\pm 12V$ power supply. It can be found in regular PC or Industrial PC.

1.1 Features

- PCI bus
- 16/8/4 channels, 14-bits analog output
- Unipolar or bipolar outputs available from each converter
- Output type (Unipolar or bipolar) and output range ($0\sim 5V$, $\pm 5V$, $0\sim 10V$, $\pm 10V$) can be software programmable
- $4\sim 20mA$ or $0\sim 20mA$ current sink to ground for each converter
- Two pacer timer interrupt source
- Double-buffered D/A latches
- Software calibration
- 16 channels DI, 16 channels DO
- SMD, short card.
- One D-Sub connector, two 20-pin flat cable connectors
- Connects directly to DB-16P, DB-16R, DB-24C, DB-24PR and DB-24POR
- Automatically detected by Windows 95/98/NT
- No base address or IRQ jumper need to set

1.2 Specifications

Digital Inputs/Outputs

- All inputs/outputs are TTL compatible
- Logic high Voltage V_{IH} : 2.4V(Min.)
- Logic low Voltage V_{IL} : 0.8V(Max.)
- Sink current I_{OL} : 8mA(Max.)
- Source current I_{OH} : 0.4mA(Max.)

Analog Outputs

- D/A converter: Quad 14 bits MDAC
- Channels: 16/8/4 independent
- Resolution: 14 bits
- Type: double-buffered, multiplying
- Integral linearity: 0.006% FSR (typical)
- Differential linearity: 0.006% FSR (typical)

Voltage Output Range:

- Unipolar: 0~5V or 0~10V
- Bipolar: $\pm 10V$ or $\pm 5V$
- Current drive: $\pm 5mA$
- Absolute accuracy : 0.01% FSR (typical)

Current Output Range:

- 0~20mA or 4~20mA
- Absolute accuracy: 0.1% FSR (typical)
- Excitation voltage range: +7V to +40V

Power Consumption:

- PIO-DA4: +5VDC @ 600mA
- PIO-DA8: +5VDC @ 800mA
- PIO-DA16: +5VDC @ 1400mA

Environmental:

- Operating Temp.: 0~60°C
- Storage Temp.: -20°C~80°C
- Humidity : 0~90% non-condensing

Dimension:

- 180 mm \times 115mm

1.3 Order Description

- PIO-DA16 : PCI bus 16 channel D/A board
- PIO-DA8 : PCI bus 8 channel D/A board
- PIO-DA4 : PCI bus 4 channel D/A board

1.3.1 Options

- DB-16P: 16 channel isolated D/I board
- DB-16R: 16 channel relay board
- DB-24PR: 24 channel power relay board
- DB-24POR: 24 channel PhotoMos output board
- DB-24C: 24-channel open-collector output board
- ADP-20/PCI : extender, 20-pin header to 20-pin header for PCI Bus I/O
- NAPPCI/win: DLLs for Windows 95/98
- NAPPCI/wnt: DLLs for Windows NT 4.0
- NAPVIEW/1: LabVIEW driver for Windows 95/98
- NAPVIEW/2: LabVIEW driver for Windows NT

1.4 PCI Data Acquisition Family

We provide a family of PCI-BUS data acquisition cards. These cards can be divided into three groups as follows:

1. PCI-series: first generation, isolated or non-isolated cards

PCI-1002/1202/1800/1802/1602: multi-function family, non-isolated

PCI-P16R16/P16C16/P16POR16/P8R8: D/I/O family, isolated

PCI-TMC12: timer/counter card, non-isolated

2. PIO-series: cost-effective generation, non-isolated cards

PIO-823/821: multi-function family

PIO-D144/D96/D64/D56/D48/D24: D/I/O family

PIO-DA16/DA8/DA4: D/A family

3. PISO-series: cost-effective generation, isolated cards

PISO-813: A/D card

PISO-P32C32/P64/C64: D/I/O family

PISO-P8R8/P8SSR8AC/P8SSR8DC: D/I/O family

PISO-730: D/I/O card

PISO-DA2: D/A card

1.5 Product Check List

In addition to this manual, the package includes the following items:

- One piece of PIO-DA16/8/4 card
- One piece of company floppy diskette or CD
- One piece of release note

It is recommended to read the release note firstly. All important information will be given in release note as follows:

1. Where you can find the software driver & utility
2. How to install software & utility
3. Where is the diagnostic program
4. FAQ

Attention!

If any of these items is missing or damaged, contact the dealer from whom you purchased the product. Save the shipping materials and carton in case you want to ship or store the product in the future.

2. Hardware configuration

2.1 Board Layout

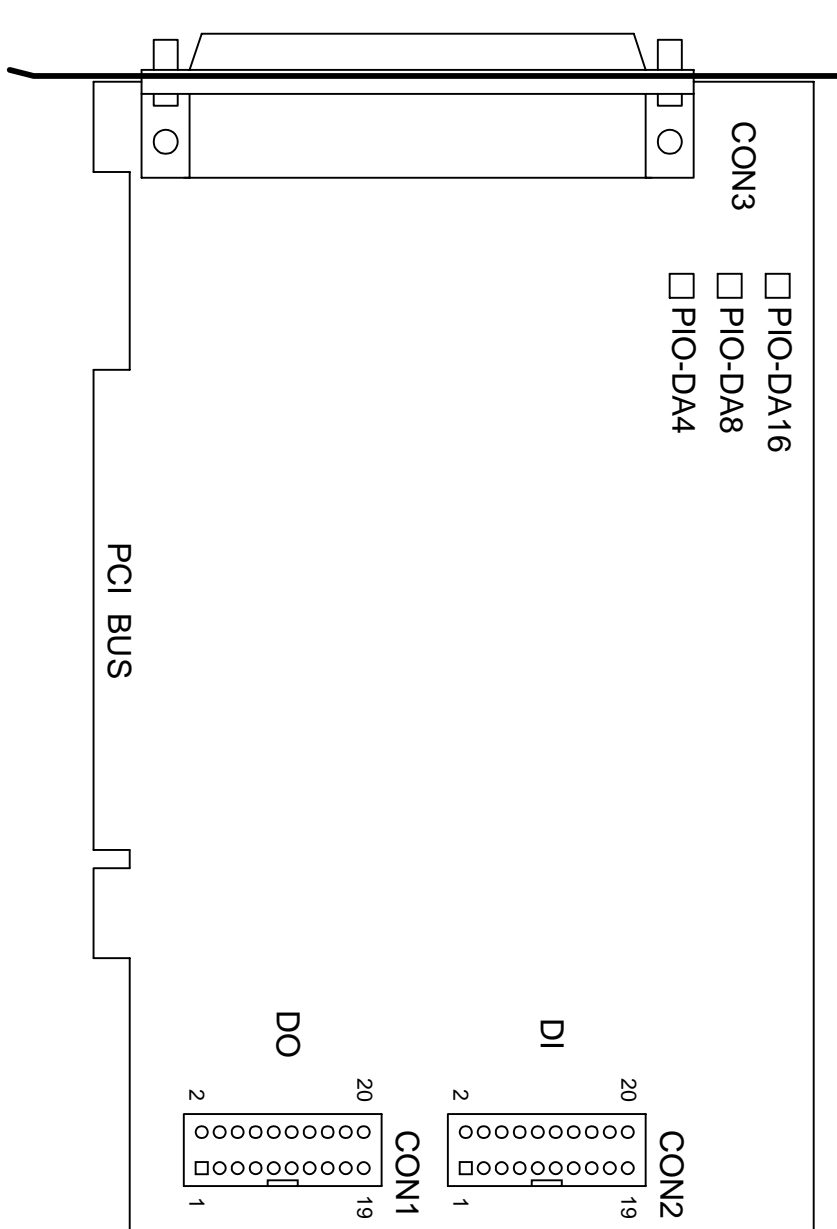

CON1: 16 channels D/O

CON2: 16 channels D/I

CON3: 16/8/4 channels D/A converter voltage/current output

2.2 Counter Architecture

There is one 8254(Timer/Counter) chip on the PIO-DA16/8/4 card. The block diagram is given as follows:

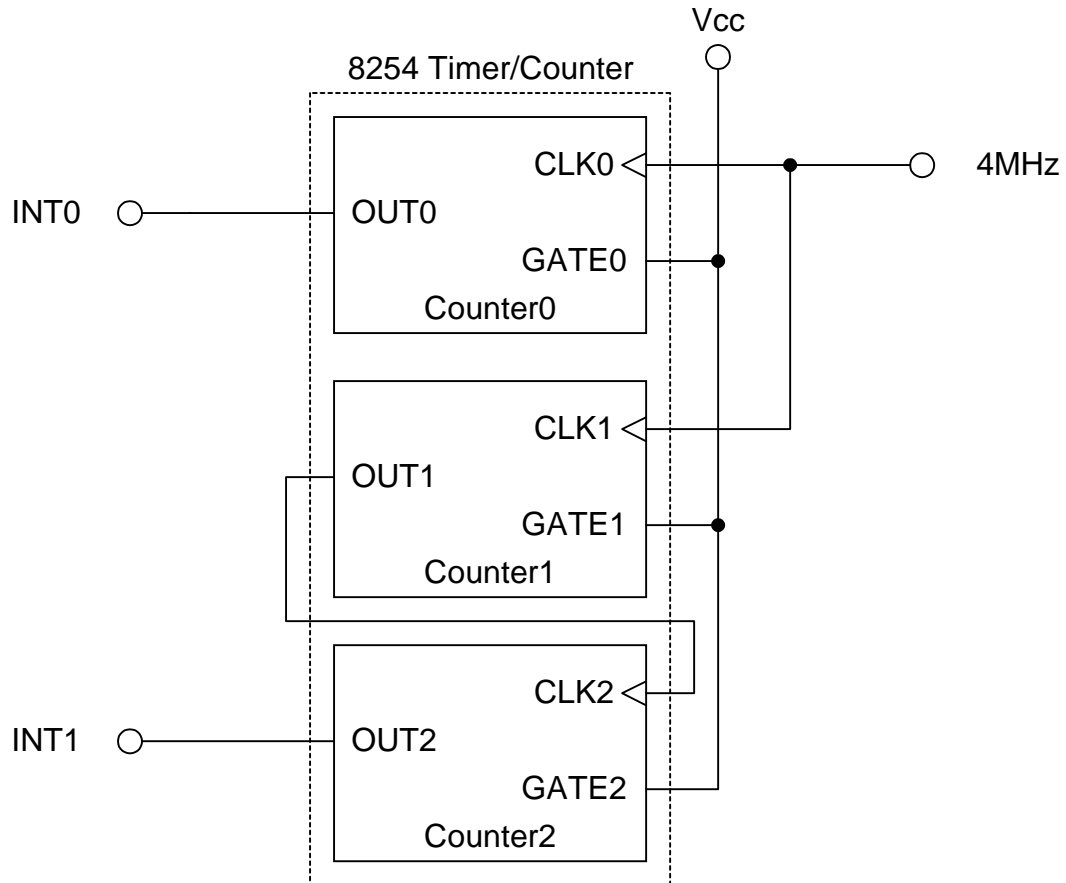

It provides two interrupt source, one is 16 bits timer output (INT0) and the other one is 32 bits timer output (INT1).

2.3 Interrupt Operation

There are two interrupt sources in PIO-DA16/8/4. These two signals are named as INT0 and INT1. Their signal sources are given as follows:

INT0: 8254 counter0 output (Refer to Sec. 2.2)

INT1: 8254 counter2 output (Refer to Sec. 2.2)

If only one interrupt signal source is used, the interrupt service routine doesn't have to identify the interrupt source. Refer to DEMO3.C and DEMO4.C for more information.

If there are more than one interrupt source, the interrupt service routine has to identify the active signals as follows: (Refer to DEMO5.C and DEMO6.C)

1. Read the new status of all interrupt signal source
2. Compare the new status with old status to identify the active signals
3. If INT0 is active, service it
4. If INT1 is active, service it
5. Save the new status to old status

Note: If the interrupt signal is too short, the new status may be as same as old status. In that condition the interrupt service routine can not identify which interrupt source is active. So the interrupt signal must be hold_active long enough until the interrupt service routine is executed. This hold_time is different for different O.S. The hold_time can be as short as micro-second or as long as second. In general, 20mS is enough for all O.S.

2.3.1 Interrupt Block Diagram of PIO-DA16/8/4

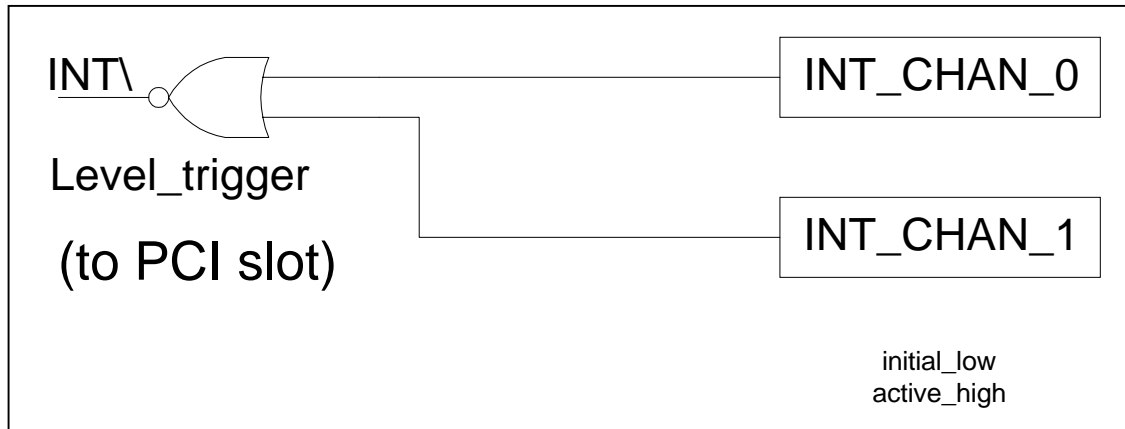

The interrupt output signal of PIO-DA16/8/4, **INT\'**, is **Level-Trigger & Active_Low**. If the INT\' generate a low_pulse, the PIO-DA16/8/4 will interrupt the PC once a time. If INT\' is fixed in low_level, the PIO-DA16/8/4 will interrupt the PC continuously. So the **INT_CHAN_0/1 must be controlled in a pules_type signals. They must be fixed in low_level statue normally and generated a high_pulse to interrupt the PC.**

The priority of INT_CHAN_0/1 is the same. If all these two signals are active at the same time, then INT\' will be active only once a time. So the interrupt service routine has to read the status of all interrupt channels for multi channels interrupt. Refer to Sec. 2.3 for more information.

DEMO5.C → for INT_CHAN_0 & INT_CHAN_1

If only one interrupt source is used, the interrupt service routine doesn't have to read the status of interrupt source. The demo program, DEMO3.C to DEMO4.C are designed for single channel interrupt demo as follows:

DEMO3.C → for INT_CHAN_1 only (initial high)

DEMO4.C → for INT_CHAN_1 only (initial low)

2.3.2 INT_CHAN_0/1

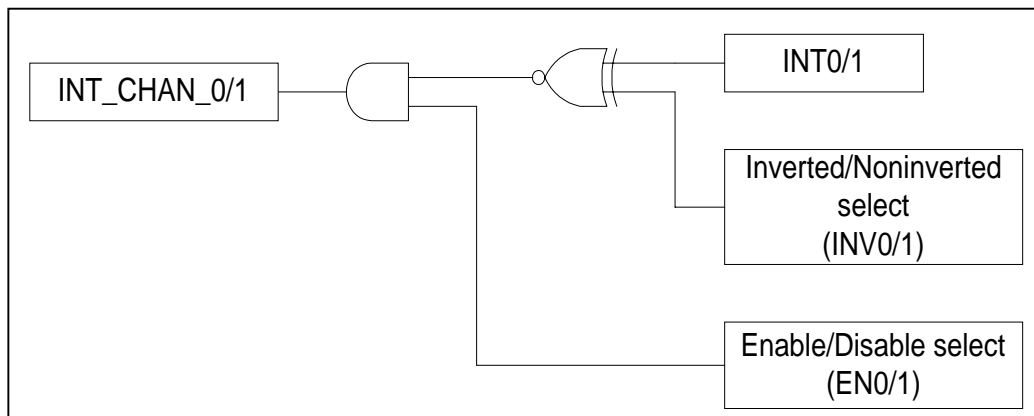

The architecture of INT_CHAN_0 and INT_CHAN_1 is the same as above figure. The only difference between INT0 and INT1 is that INT_CHAN_0 signal source from 8254 counter0 output and INT_CHAN_1 signal source from 8254 counter2 output.

The INT_CHAN_0/1 must be fixed in low level state normally and generated a high_pulse to interrupt the PC.

The EN0/1 can be used to enable/disable the INT_CHAN_0/1 as follows: (Refer to Sec.3.3.4)

EN0/1 = 0 → INT_CHAN_0/1 = disable

EN0/1 = 1 → INT_CHAN_0/1 = enable

The INV0/1 can be used to invert/non-invert the INT0/1 as follows: (Refer to Sec.3.3.6)

INV0/1 = 0 → INT_CHAN_0/1 = inverted state of INT0/1

INV0/1 = 1 → INT_CHAN_0/1 = non-inverted state of INT0/1

As above discussion, **if the INT\ fixed in low level state, the PIO-DA16/8/4 will interrupt the PC continuous. So interrupt service routine should use INV0/1 to invert/non-invert the INT0/1 to generate high_pulse** (Refer to next section)

2.3.3 Initial_high, active_low Interrupt source

If the INTO (8254 counter0 output) is an initial_high, active_low signal (depend on 8254 counter mode), the interrupt service routine should use INV0 to invert/ non-invert the INTO for high_pulse generation as follows: (Refer to DEMO3.C)

Initial set:

```
now_int_state=1;          /* initial state for INTO    */
outportb(wBase+0x2a,0);  /* select the inverted INTO */
```

```
void interrupt irq_service()
{
if (now_int_state==1)      /* now INTO is changed to LOW      */(a)
{
/* --> INT_CHAN_0=!INT0=HIGH now */
COUNT_L++;              /* find a LOW_pulse (INT0)        */
If((inport(wBase+7)&1)==0)/* the INTO is still fixed in LOW */
{
/* → need to generate a high_pulse */
outportb(wBase+0x2a,1);/* INV0 select the non-inverted input */(b)
/* INT_CHAN_0=INT0=LOW --> */
/* INT_CHAN_0 generate a high_pulse */
now_int_state=0;        /* now INTO=LOW */
}
else now_int_state=1;    /* now INTO=HIGH */
/* don't have to generate high_pulse */
}
else                        /* now INTO is changed to HIGH      */(c)
{
/* --> INT_CHAN_0=INT0=HIGH now */
COUNT_H++;              /* find a HIGH_pulse (INT0)       */
If((inport(wBase+7)&1)==1)/* the INTO is still fixed in HIGH */
{
/* need to generate a high_pulse */
outportb(wBase+0x2a,0);/* INV0 select the inverted input  */(d)
/* INT_CHAN_0=!INT0=LOW --> */
/* INT_CHAN_0 generate a high_pulse */
now_int_state=1;        /* now INTO=HIGH */
}
else now_int_state=0;    /* now INTO=LOW */
/* don't have to generate high_pulse */
}
}
if (wIrq>=8) outportb(A2_8259,0x20);
outportb(A1_8259,0x20);
}
```

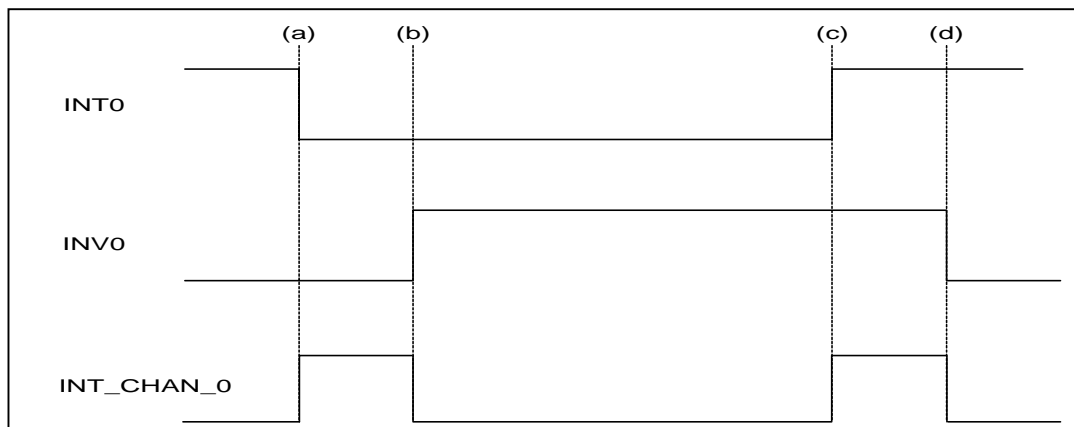

2.3.4 Initial_low, active_high Interrupt source

If the INTO (8254 counter0 output) is an initial_low, active_high signal (depend on 8254 counter mode), the interrupt service routine should use INVO to invert/non-invert the INTO for high_pulse generation as follows: (Refer to DEMO4.C)

Initial set:

```
now_int_state=0; /* initial state for INTO */
outportb(wBase+0x2a,1); /* select the non-inverted INTO */
```

```
void interrupt irq_service()
{
if (now_int_state==1) /* now INTO is changed to LOW */(c)
{
/* --> INT_CHAN_0=!INT0=HIGH now */
COUNT_L++; /* find a LOW_pulse (INT0) */
If((inport(wBase+7)&1)==0)/* the INTO is still fixed in LOW */
{
/* → need to generate a high_pulse */
outportb(wBase+0x2a,1);/* INVO select the non-inverted input */(d)
/* INT_CHAN_0=INT0=LOW --> */
/* INT_CHAN_0 generate a high_pulse */
now_int_state=0; /* now INTO=LOW */
}
else now_int_state=1; /* now INTO=HIGH */
/* don't have to generate high_pulse */
}
else /* now INTO is changed to HIGH */(a)
{
/* --> INT_CHAN_0=INT0=HIGH now */
COUNT_H++; /* find a High_pulse (INT0) */
If((inport(wBase+7)&1)==1)/* the INTO is still fixed in HIGH */
{
/* need to generate a high_pulse */
outportb(wBase+0x2a,0);/* INVO select the inverted input */(b)
/* INT_CHAN_0=!INT0=LOW --> */
/* INT_CHAN_0 generate a high_pulse */
now_int_state=1; /* now INTO=HIGH */
}
else now_int_state=0; /* now INTO=LOW */
/* don't have to generate high_pulse */
}
}
if (wIrq>=8) outportb(A2_8259,0x20);
outportb(A1_8259,0x20);
}
```

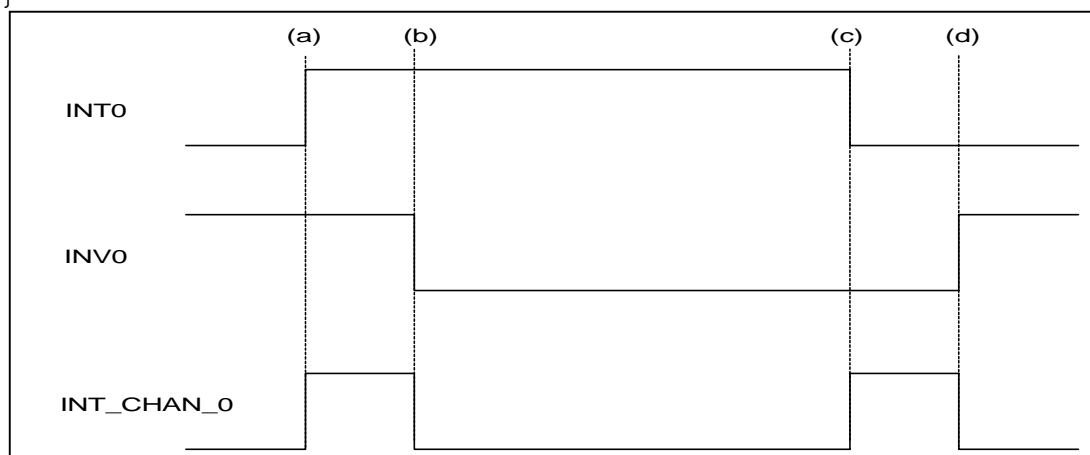

2.3.5 Multiple Interrupt Source

Assume : INT0 is initial Low, active High,

INT1 is initial High, active Low

as follows:

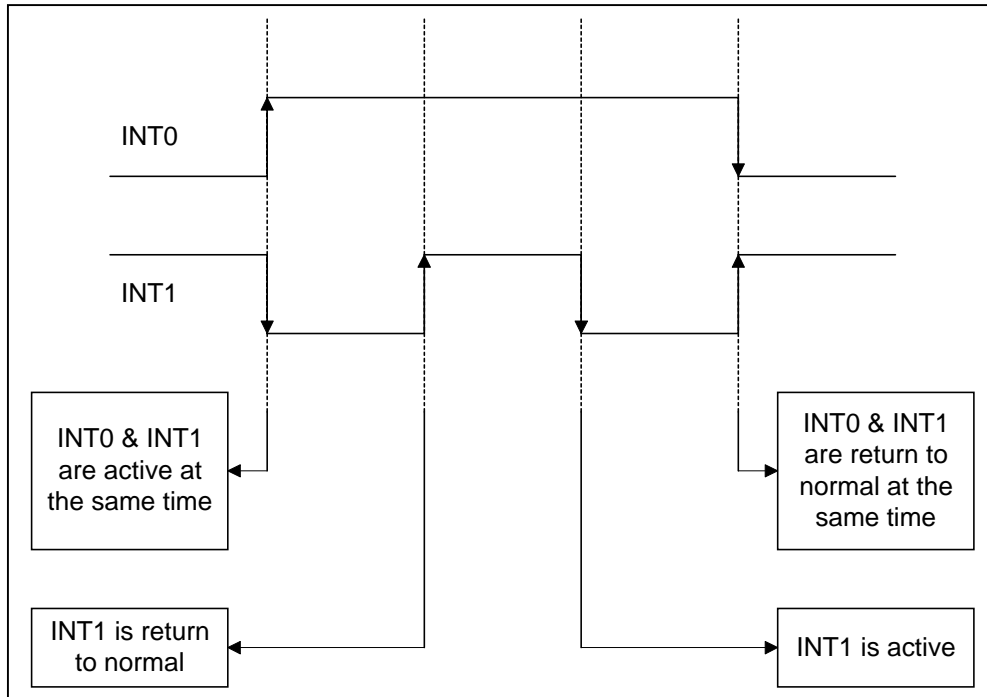

Refer to DEMO5.C for source program. **All of these falling-edge & rising-edge can be detected by DEMO5.C.**

Note: when the interrupt is active, the user program has to identify the active signals. These signals maybe active at the same time. So the interrupt service routine has to service all active signals at the same time.

```

/* ----- */
/* Note : 1.The hold_time of INT_CHAN_0 & INT_CHAN_1 must long */
/*          enough. */
/*          2.The ISR must read the interrupt status again to */
/*          identify the active interrupt source. */
/*          3.The INT_CHAN_0 & INT_CHAN_1 can be active at the same */
/*          time. */
/* ----- */
void interrupt irq_service()
{
/* now ISR can not know which interrupt is active */
new_int_state=inportb(wBase+7)&0x03; /* read all interrupt */
/* signal state */
int_c=new_int_state^now_int_state; /* compare new_state to */
/* old_state */

if ((int_c&0x01)==1) /* INT_CHAN_0 is active */
{
if ((new_int_state&1)==0) /* INT0 change to low now */
{
INT0_L++;
}
else /* INT0 change to high now */
{
INT0_H++;
}
invert=invert^1; /* generate high_pulse */
}

if ((int_c&0x02)==2) /* INT_CHAN_1 is active */
{
if ((new_int_state&2)==0) /* INT1 change to low now */
{
INT1_L++;
}
else /* INT1 change to high now */
{
INT1_H++;
}
invert=invert^2; /* generate high_pulse */
}

now_int_state=new_int_state; /* update interrupt status */
outportb(wBase+0x2a,invert); /* generate a high pulse */

if (wIrq>=8) outportb(A2_8259,0x20);
outportb(A1_8259,0x20);
}

```

2.4 D/I/O Block Diagram

The PIO-DA16/8/4 provides 16 channels digital input and 16 channels digital output. All signal levels are TTL compatible. The connection diagram and block diagram are given as follows:

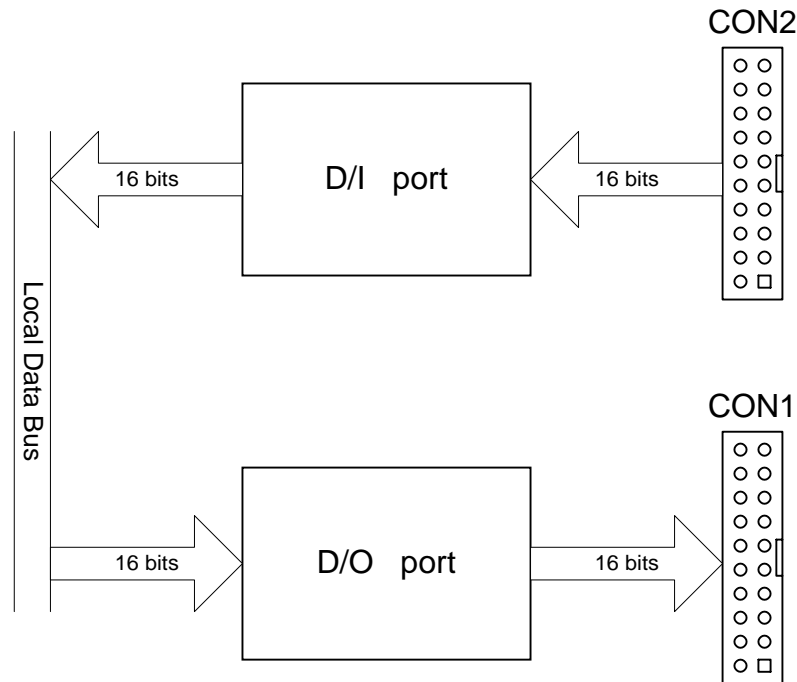

The D/I port can be connected to the DB-16P. The DB-16P is a 16 channels isolated digital input daughter board. The D/O port can be connected to the DB-16R or DB-24PR. The DB-16R is a 16 channels relay output board. The DB-24PR is a 24 channels power relay output board.

2.4.1 DI Port Architecture (CON2)

When the PC is power-up, all operation of DI port (CON2) is disable. The enable/disable of DI port is controlled by the RESET\ signal. Refer to Sec. 3.3.1 for more information about RESET\ signal.

- The RESET\ is in Low-state → all DI operation is disable
- The RESET\ is in High-state → all DI operation is enable

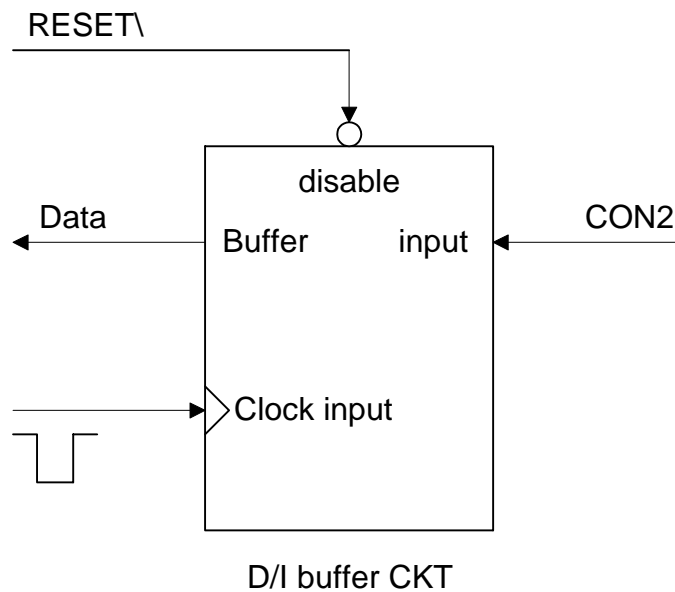

2.4.2 DO Port Architecture (CON1)

When the PC is power-up, all of DO states are clear to low state. The RESET\ signal is used to clear DO states. Refer to Sec. 3.3.1 for more information about RESET\ signal.

- The RESET\ is in Low-state → all DOs are clear to low state

The block diagram of DO is given as follows:

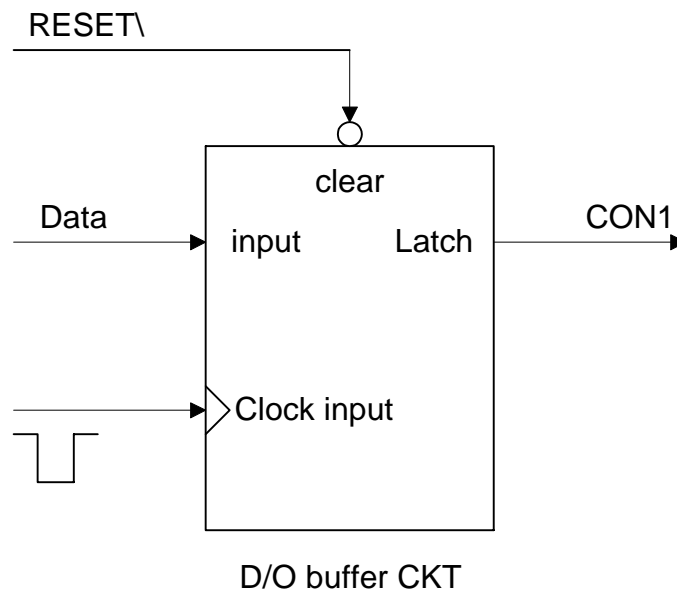

2.5 D/A Architecture

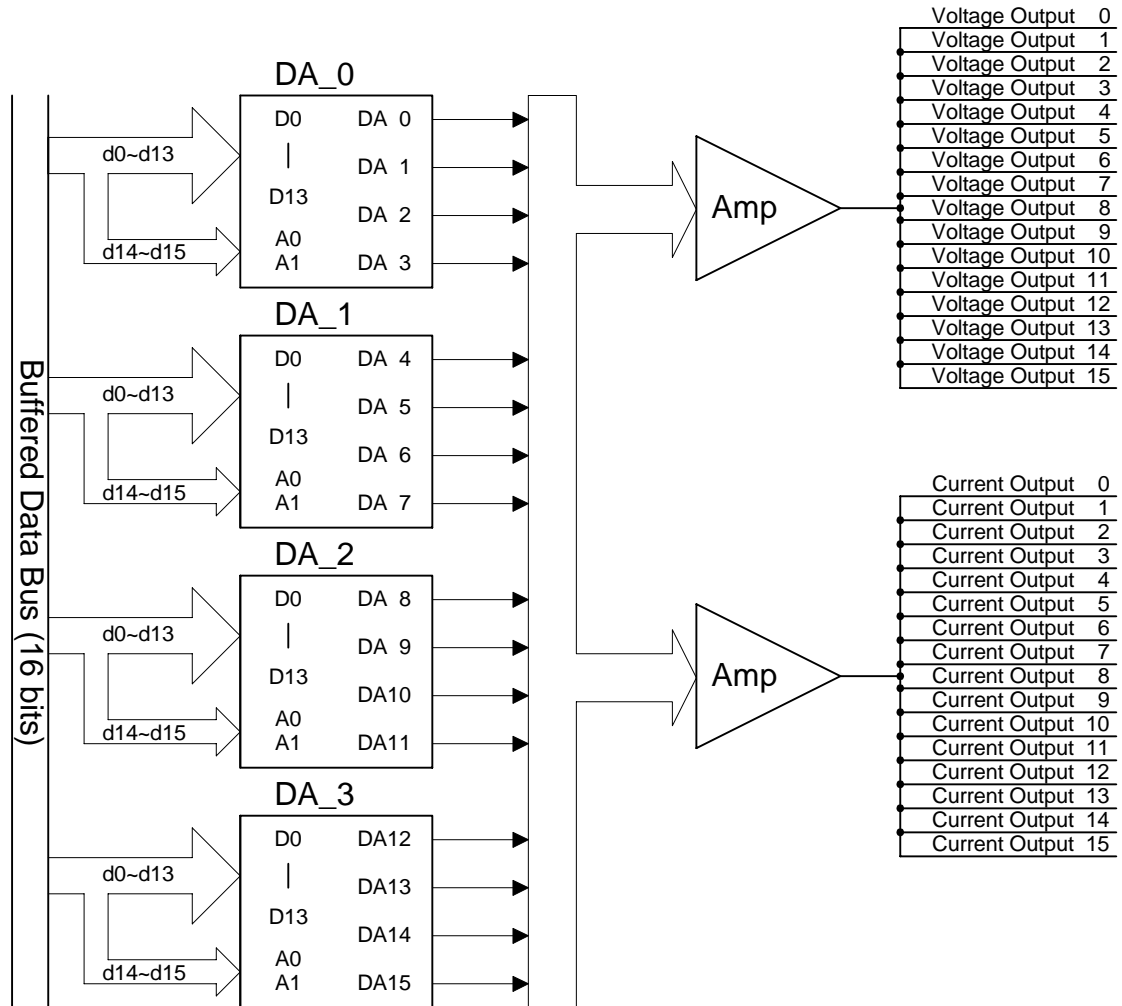

The PIO-DA16/8/4 offers 16/8/4 channels double-buffered digital to analog output and provide voltage output & current output simultaneous.

2.6 D/A Convert Operation

The D/A converters on PIO-DA16/8/4 have 14 bits resolution, so the digital data value range from 0x0000 to 0x3fff. And the hardware is designed to output voltage range from -10.1~+10.1 as follows:

0x0000 → about -10.1 volt

0x3FFF → about +10.1 volt

In the conventional design, there will be some VRs to adjust to let 0x0000=-10.0V & 0x3fff=+10.0V for voltage output. Also these VRs have to be adjusted to let 0x1fff=0mA & 0x3fff=20mA for current output. In the conventional design, these VRs are common for voltage/current output. So the user has to perform calibration when change from voltage to current. Also If these VRs are changed, the user has to perform calibration again. This procedure is complex & heavy load. The PIO-DA16/8/4 use software calibration to replace this complex procedure as following:

- for each voltage output channel we find two hex value MaxV[n] and MinV[n] (stored to on board EEPROM). MaxV[n] mapping to accurate +10V and MinV[n] mapping to accurate -10V.
- For each current output channel we also find two hex value MaxI[n] and MinI[n] (stored to on board EEPROM). MaxI[n] mapping to accurate 20mA and MinI[n] mapping to accurate 0mA.

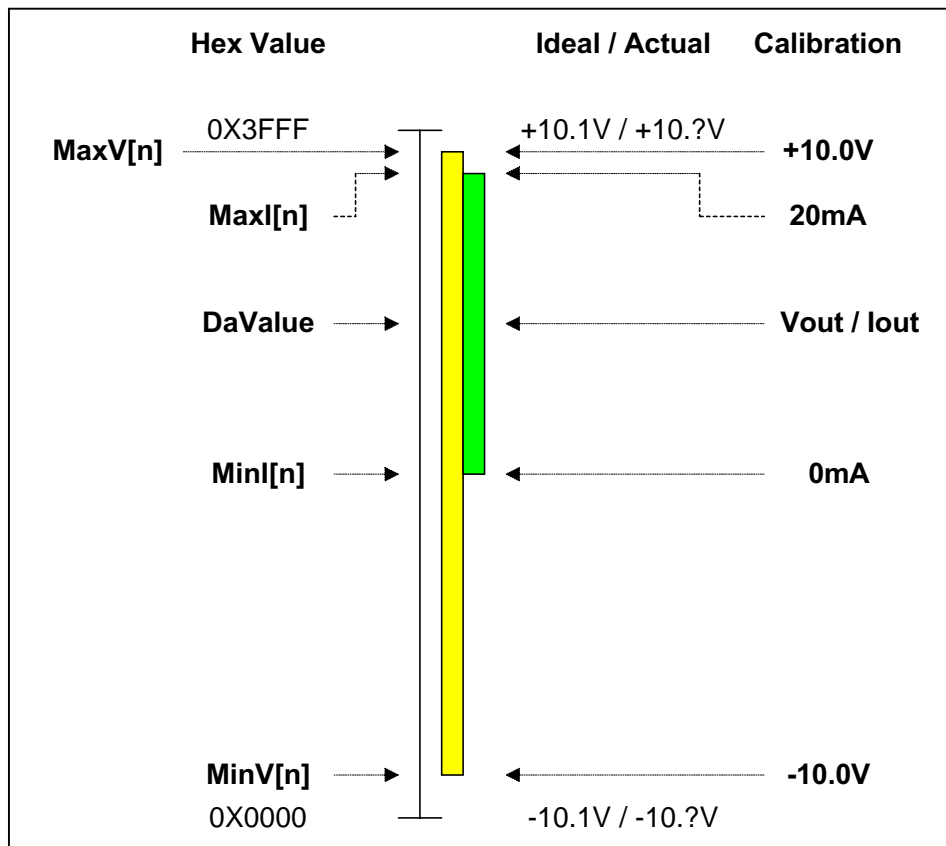

Therefore the software can calibrate the analog output without any hardware Trim-pot adjustment. For example,

channel n	MinV[n]	MaxV[n]	MinI[n]	MaxI[n]
0	134	16297	8180	15943
1	137	16293	8172	15976
2	132	16296	8199	15949
3	134	16391	8177	15963
4	135	16298	8165	15955
5	131	16292	8150	15947
6	136	16295	8172	15968
7	134	16297	8163	15961
8	134	16294	8188	15959
9	132	16295	8169	15948
10	135	16298	8172	15946
11	133	16296	8177	15975
12	131	16292	8159	15942
13	134	16297	8173	15973
14	132	16293	8168	15949
15	133	16295	8175	15965

If the user want to send Vout(volt) to channel n, the calibrated hex value, DaValue, sent to D/A converter is give as follows:

```
DeltaV[n]=20.0/(MaxV[n]-MinV[n]); /* DeltaV[n]=volt per count at channel_n */
DaValue=(Vout+10.0)/DeltaV[n]+MinV[n]; /* DaValue=Hex value send to D/A */
pio_da16_da(n, DaValue); /* send DaValue to channel n */
```

If the user want to send Iout(mA) to channel n, the calibrated hex value, DaValue, sent to D/A converter is give as follows: (Refer to DEMO9.C)

```
DeltaI[n]=20.0/(MaxI[n]-MinI[n]); /* DeltaI[n]=mA per count at channel_n */
DaValue=Iout/DeltaI[n]+MinI[n]; /* DaValue=Hex value send to D/A */
pio_da16_da(n, DaValue); /* send DaValue to channel n */
```

Refer to DEMO7.C and DEMO9.C for more information.

2.6.1 Output Range and Resolution

The voltage output range of PIO-DA16/8/4 is always in $\pm 10.1V$ and the current output range is always in 0~22mA as following:

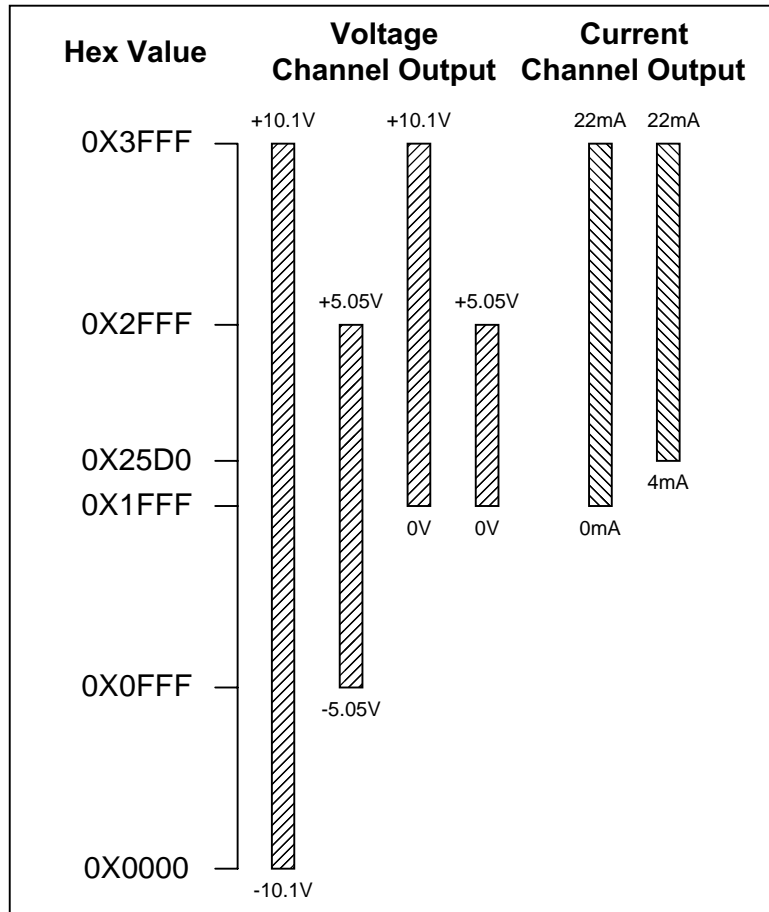

The resolution of each range is given as follows:

Configuration	Equivalent Bit	Resolution
-10V ~ +10V	14 bit	1.22mV
0V ~ 10V	13 bit	1.22mV
-5V ~ +5V	13 bit	1.22mV
0V ~ +5V	12 bit	1.22mV
0mA ~ 20mA	13 bit	2.70uA
4mA ~ 20mA	13 bit	2.70uA

2.6.2 The $\pm 10V$ Voltage Output

The voltage output of PIO-DA16/8/4 is always in $\pm 10.1V$ range. If the user need to output $\pm 10V$ range, the software is same as described in Sec.2.6. Because the user want to output $\pm 10V$ range, V_{out} will be in $\pm 10V$ range, the DaValue will be about from 0x0000 to 0x3fff. This means the resolution is about 14 bit.

2.6.3 The $\pm 5V$ Voltage Output

The voltage output of PIO-DA16/8/4 is always in $\pm 10.1V$ range. If the user need to output $\pm 5V$ range, the software is same as described in Sec.2.6. Because the user want to output $\pm 5V$ range, V_{out} will be in $\pm 5V$ range, the DaValue will be about from 0x0fff to 0x2fff. This means the resolution is about 13 bit.

2.6.4 The 0~10V Voltage Output

The voltage output of PIO-DA16/8/4 is always in $\pm 10.1V$ range. If the user need to output 0~10V range, the software is same as described in Sec.2.6. Because the user want to output 0~10V range, V_{out} will be in 0~10V range, the DaValue will be about from 0x1fff to 0x3fff. This means the resolution is about 13 bit.

2.6.5 The 0~5V Voltage Output

The voltage output of PIO-DA16/8/4 is always in $\pm 10.1V$ range. If the user need to output 0~5V range, the software is same as described in Sec.2.6. Because the user want to output 0~5V range, V_{out} will be in 0~5V range, the wDaValue will be about from 0x1fff to 0x2fff. This means the resolution is about 12 bit.

2.6.6 The 0~20mA Current Output

The current output of PIO-DA16/8/4 is always in 0~22mA range. If the user need to output 0~20mA, the software is the same as described in Sec.2.6. Because the user want to output 0~20mA, Iout will be in the 0~20mA range. So the DaValue will be about from 0x1fff to 0x3fff. This means the resolution is about 13 bit.

2.6.7 The 4~20mA Current Output

The current output of PIO-DA16/8/4 is always in 0~22mA range. If the user need to output 4~20mA, the software is the same as described in Sec.2.6. Because the user want to output 4~20mA, Iout will be in the 4~20mA range. So the DaValue will be about from 0x2600 to 0x3fff. This means the resolution is about 13 bit.

2.6.8 No VR & No Jumper Design

In the conventional 12-bit D/A board, for example A-626/A-628, there are many jumpers for the following functions:

- (1) select the reference voltage (internal $-10/-5$ /or external)
- (2) select unipolar/bipolar (0-10V or ± 10 V)
- (3) select different output range (0-10V or 0-5V)

And there are many VRs for the following functions:

- (1) voltage output offset adjustment
- (2) voltage output full-scale adjustment
- (3) current output offset adjustment
- (4) current output full-scale adjustment

There are so many VRs and jumpers, this make the QC and re-calibration very difficult. Every step must be handle by human hand. It is not a happy job for people to calibrate these D/A boards.

When we design the PIO-DA/16/8/4, we try to remove all these terrible VRs and jumpers but still maintain the same precision and performance. In the long run, we select a 14-bit D/A converter and adapt the software calibration to provide at least the same performance & precision as A-626/A-628 as follows:

Configuration	Equivalent Bit	Resolution
-10V ~ +10V	14 bit	1.22mV
0V ~ 10V	13 bit	1.22mV
-5V ~ +5V	13 bit	1.22mV
0V ~ +5V	12 bit	1.22mV
0mA ~ 20mA	13 bit	2.70uA
4mA ~ 20mA	13 bit	2.70uA

- All these VRs and jumpers are removed.
- All calibrations can be done by software.
- All channel configurations can be selected by software, no need to change any hardware.
- The Precision is at least the same as A-626/A628.
- All these 16 channels can be configured and used in the different configuration at the same time. (For example, channel_0= ± 10 V, channel_1=4~20mA, channel_2=0~5V, ...).
- All these features can be implemented in a small, compact, reliable and half-size PCB.

2.6.9 Factory Software Calibration

It is recommended to use a 16-bit A/D card to calibration the PIO-DA16/8/4. The I-7000 series is a set of precision remote control modules. The I-7017 is 8-channel 16-bit precision A/D module (24-bit sigma-delta A/D converter), we use two I-7017 for voltage output calibration and another two I-7017 for current output calibration.

The steps for channel_n voltage calibration are given as follows:

Step 1: DaValue=0
Step 2: send DaValue to PIO-DA16/8/4 channel_n
Step 3: measure the I-7017 channel_n,
 If this value is just $\geq -10V$, than goto step 5
Step 4: increment DaValue, goto step 2
Step 5: MinV[n]=DaValue-1
Step 6: DaValue=0x3fff
Step 7: send DaValue to PIO-DA16/8/4 channel_n
Step 8: measure the I-7017 channel_n,
 If this value is just $\geq +10V$, than goto step 10
Step 9: increment DaValue, goto step 7
Step 10: MaxV[n]=DaValue
Note: MinV[n] & MaxV[n] are discribed in Sec.2.6

The steps for channel_n current calibration are given as follows:

Step 1: DaValue=0x1fff
Step 2: send DaValue to PIO-DA16/8/4 channel_n
Step 3: measure the I-7017 channel_n,
 If this value is just $\geq 0mA$, than goto step 5
Step 4: increment DaValue, goto step 2
Step 5: MinI[n]=DaValue-1
Step 6: DaValue=0x3fff
Step 7: send DaValue to PIO-DA16/8/4 channel_n
Step 8: measure the I-7017 channel_n,
 If this value is just $\geq 20mA$, than goto step 10
Step 9: increment DaValue, goto step 7
Step 10: MaxI[n]=DaValue
Note: MinI[n] & MaxI[n] are discribed in Sec.2.6

2.6.10 User Software Calibration

User can perform calibration himself with a voltage meter and a current meter.

Step1: Run DEMO12.EXE

Step2: Select card number (PIO-DA16/PIO-DA8/PIO-DA4) that you want to calibrate

Step3: Select which item (MinV[n]/MaxV[n]/MinI[n]/MaxI[n]) that you want to calibrate

Step4: To measure the analog output by voltage meter or current meter and decide to increment or decrement DaValue. The DaValue will send to D/A converter at once. By the measured result user can find the proper value of DaValue that mapping to accurate output value.

Step5: Repeat step4 for each channel

After this procedure, the new data of MinV[n]/MaxV[n]/MinI[n]/MaxI[n] will be stored to on board EEPROM.

User can run DEMO10.EXE to back-up the old calibration data to "A:\DA16.DAT" before new calibration.

If something error during the new calibration, user can run DEMO11.EXE to download data from "A:\DA16.DAT" to EEPROM.

Note :

DEMO10.EXE → save old calibration data

DEMO11.EXE → download old calibration data

DEMO12.EXE → perform new calibration

2.6.10 Voltage Output Connection

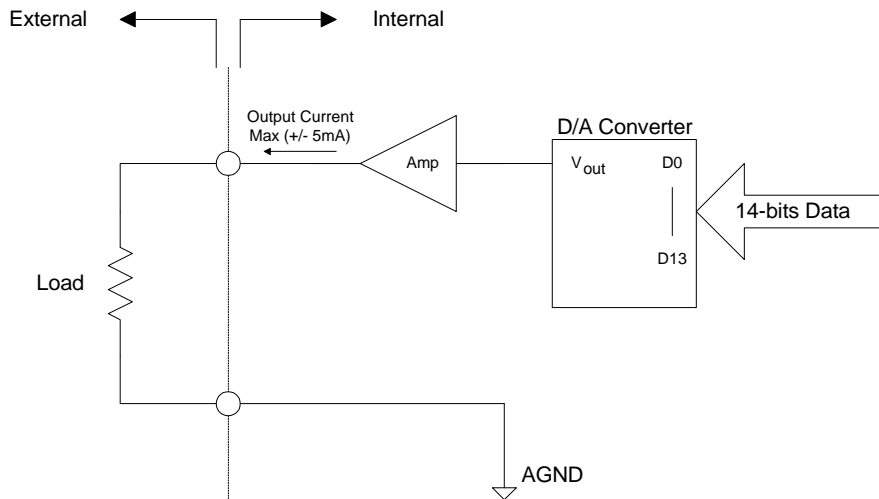

2.6.11 Current Output Connection

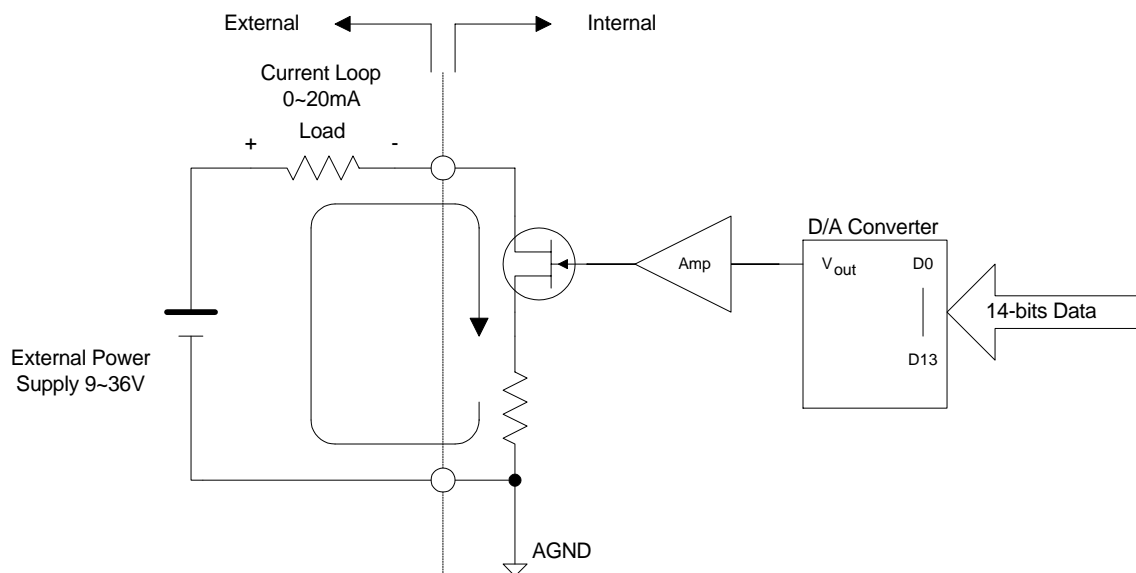

2.7 The Connectors

CON1: Digital Output Connector

Pin Assignment:

Pin	Name	Pin	Name
1	Digital Output 0	2	Digital Output 1
3	Digital Output 2	4	Digital Output 3
5	Digital Output 4	6	Digital Output 5
7	Digital Output 6	8	Digital Output 7
9	Digital Output 8	10	Digital Output 9
11	Digital Output 10	12	Digital Output 11
13	Digital Output 12	14	Digital Output 13
15	Digital Output 14	16	Digital Output 15
17	PCB ground	18	PCB ground
19	PCB +5V	20	PCB +12V

All signals are TTL compatible.

CON2: Digital input connector

Pin assignment:

Pin	Name	Pin	Name
1	Digital Input 0	2	Digital Input 1
3	Digital Input 2	4	Digital Input 3
5	Digital Input 4	6	Digital Input 5
7	Digital Input 6	8	Digital Input 7
9	Digital Input 8	10	Digital Input 9
11	Digital Input 10	12	Digital Input 11
13	Digital Input 12	14	Digital Input 13
15	Digital Input 14	16	Digital Input 15
17	PCB ground	18	PCB ground
19	PCB +5V	20	PCB +12V

All signals are TTL compatible.

CON3: Analog Output Connector

Pin Assignment:

Pin	Name	Pin	Name
1	Voltage Output 0	20	Current Output 0
2	Voltage Output 1	21	Current Output 1
3	Voltage Output 2	22	Current Output 2
4	Voltage Output 3	23	Current Output 3
5	Analog ground	24	Analog ground
6	Voltage Output 4	25	Current Output 4
7	Voltage Output 5	26	Current Output 5
8	Voltage Output 6	27	Current Output 6
9	Voltage Output 7	28	Current Output 7
10	Analog ground	29	Analog ground
11	Voltage Output 8	30	Current Output 8
12	Voltage Output 9	31	Current Output 9
13	Voltage Output 10	32	Current Output 10
14	Voltage Output 11	33	Current Output 11
15	Analog ground	34	Current Output 12
16	Voltage Output 12	35	Current Output 13
17	Voltage Output 13	36	Current Output 14
18	Voltage Output 14	37	Current Output 15
19	Voltage Output 15		

2.8 Daughter Boards

2.8.1 DB-37

The DB-37 is a general purpose daughter board for D-sub 37 pins. It is designed for easy wire connection.



2.8.2 DN-37

The DN-37 is a general purpose daughter board for DB-37 with DIN-Rail Mounting. This board is designed for easy wire connection.

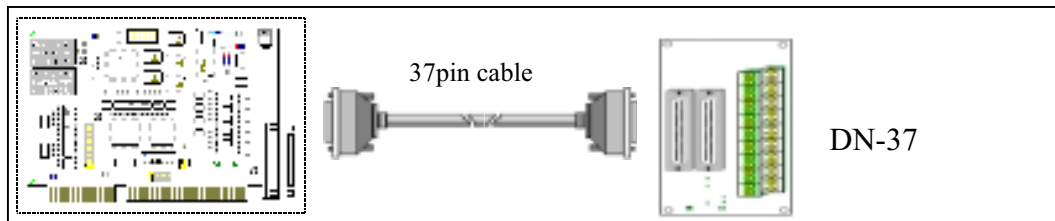

2.8.3 DB-8125

The DB-8125 is a general purpose screw terminal board. It is designed for easy wire connection. There are one DB-37 & two 20-pin flat-cable headers in the DB-8125.

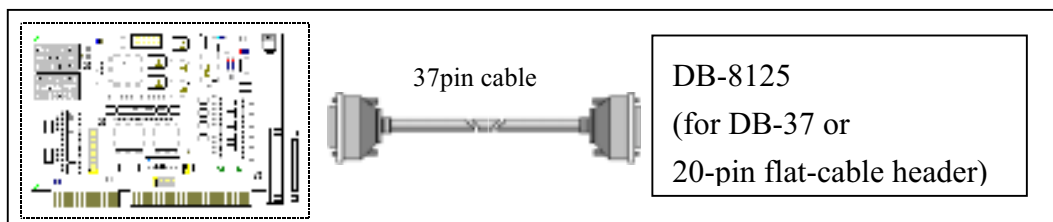

2.8.4 DB-16P Isolated Input Board

The DB-16P is a 16-channels isolated digital input daughter board. The optically isolated inputs of the DB-16P consist of a bi-directional opto-coupler with a resistor for current sensing. You can use the DB-16P to sense DC signal from TTL levels up to 24V or use the DB-16P to sense a wide range of AC signals. You can use this board to isolated the computer from large common-mode voltage, ground loops and transient voltage spike that often occur in industrial environments.

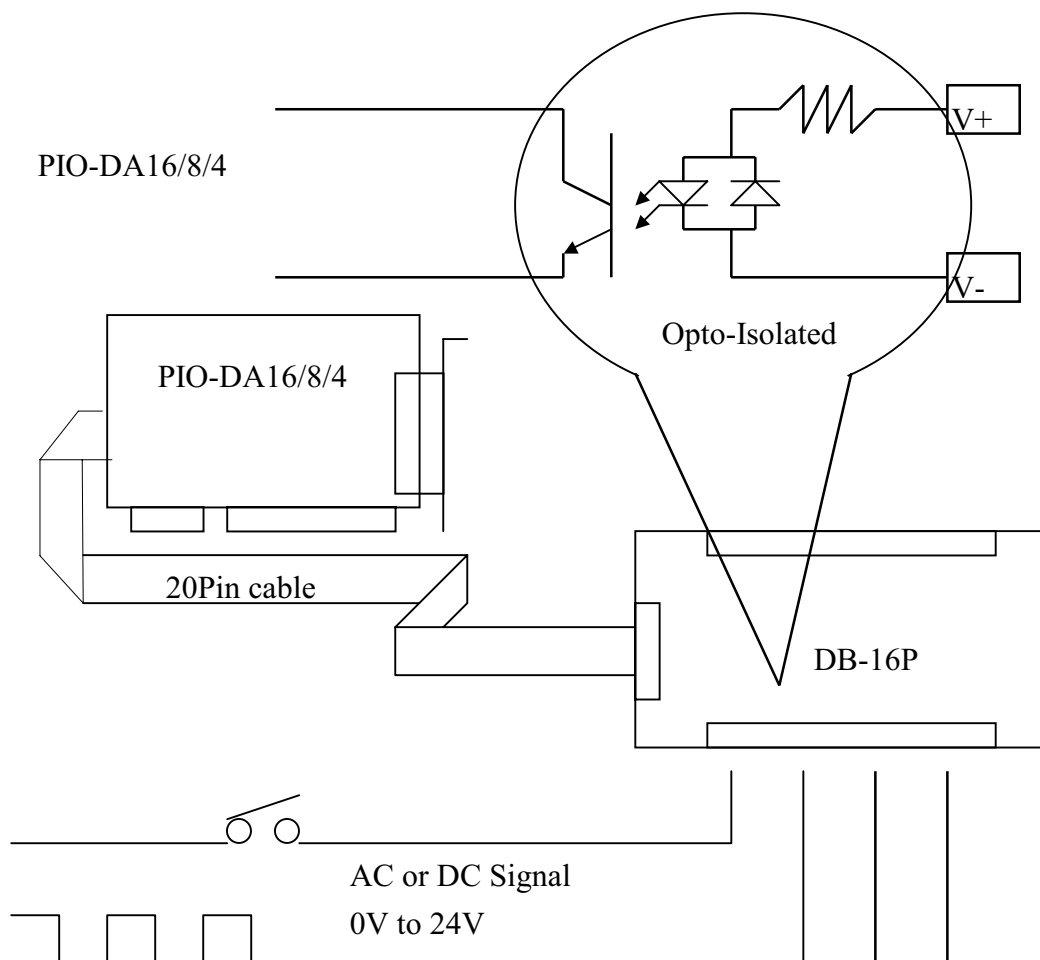

2.8.5 DB-16R Relay Board

The DB-16R, 16-channel relay output board, consists of 16 form C relays for efficient switch of load by programmed control. It is connector and functionally compatible with 785 series board but with industrial type terminal block. The relay are energized by apply 5 voltage signal to the appropriated relay channel on the 20-pin flat connector. There are 16 enunciator LEDs for each relay, light when their associated relay is activated. To avoid overloading your PC's power supply, this board provides a screw terminal for external power supply.

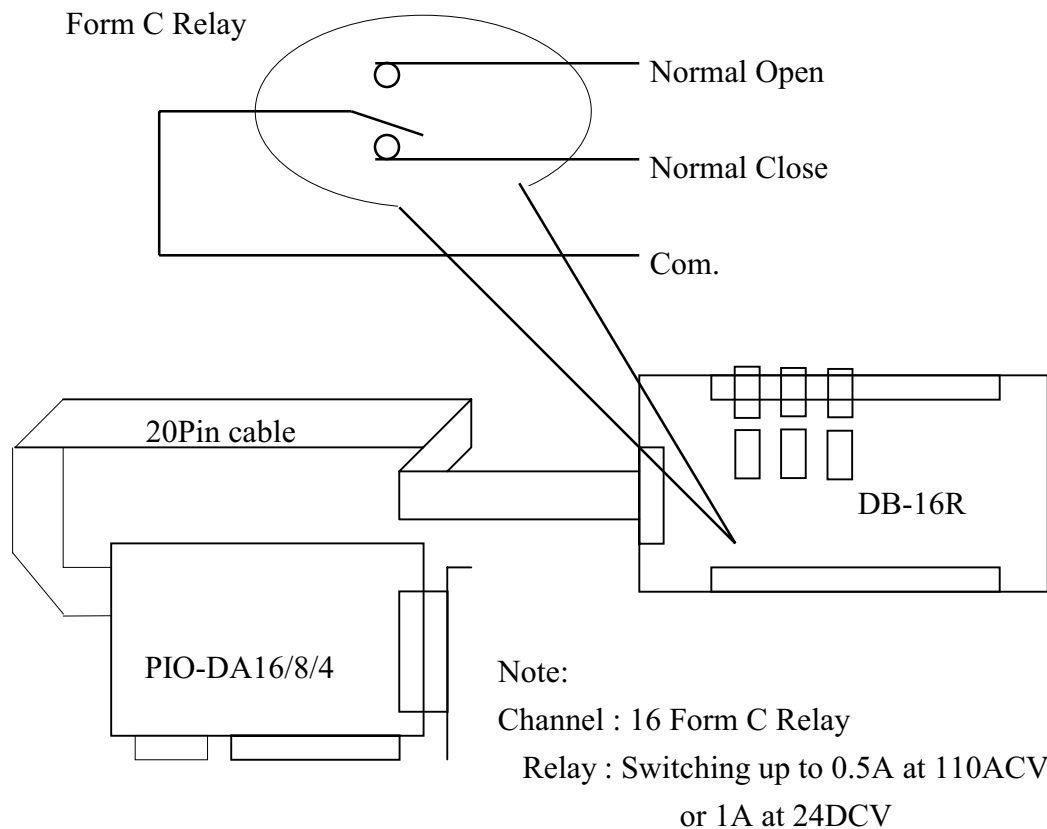

2.8.6. DB-24PR, DB-24POR, DB-24C

DB-24PR	24*power relay, 5A/250V
DB-24POR	24*PhotoMOS relay, 0.1A/350VAC
DB-24C	24*open collector, 100mA per channel, 30V max.

The DB-24PR, 24-channel power relay output board, consists of 8 form C and 16 form A electromechanical relays for efficient switching of load programmed control. The contact of each relay can control a 5A load at 250ACV/30VDCV. The relay is energized by applying a 5 voltage signal to the appropriate relay channel on the 20-pin flat cable connector (just used 16 relays) or 50-pin flat cable connector. (OPTO-22 compatible, for DIO-24 series). Twenty-four enunciator LEDs, one for each relay, light when their associated relay is activated. To avoid overloading your PC' s power supply , this board needs a +12VDC or +24VDC external power supply.

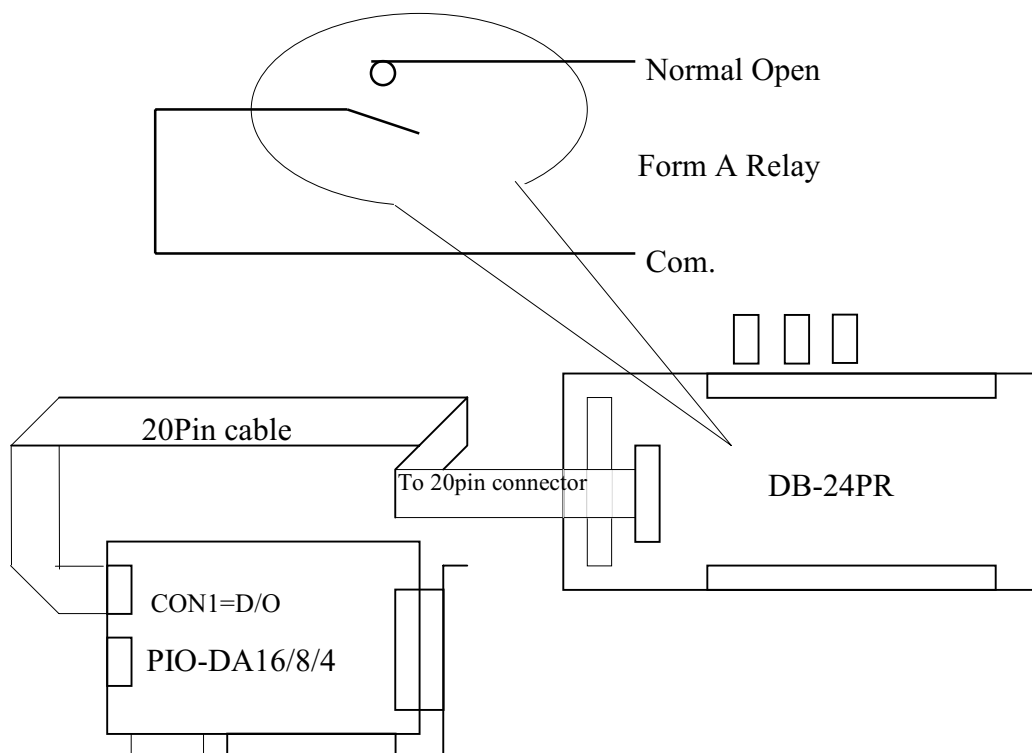

Note:

50-Pin connector (OPTO-22 compatible), for DIO-24, DIO-48, DIO-144, PIO-D144, PIO-D96, PIO-D56, PIO-D48, PIO-D24

20-Pin connector for 16 channel digital output, A-82X, A-62X, DIO-64, ISO-DA16/DA8, PIO-D56, PIO-DA16/8/4

Channel : 16 Form A Relay , 8 Form C Relay

Relay : switching up to 5A at 110ACV / 5A at 30DCV

2.8.7. Daughter Board Comparison Table

	20-pin flat-cable header	50-pin flat-cable header	DB-37 Header
DB-37	No	No	Yes
DN-37	No	No	Yes
ADP-37/PCI	No	Yes	Yes
ADP-50/PCI	No	Yes	No
DB-24P	No	Yes	No
DB-24PD	No	Yes	Yes
DB-16P8R	No	Yes	Yes
DB-24R	No	Yes	No
DB-24RD	No	Yes	Yes
DB-24C	Yes	Yes	Yes
DB-24PR	Yes	Yes	No
Db-24PRD	No	Yes	Yes
DB-24POR	Yes	Yes	Yes
DB-24SSR	No	Yes	Yes

Note : There is no 50 pin flat-cable header in PIO-DA16/8/4. The PIO-DA16/8/4 has one DB-37 connector and two 20-pin flat-cable headers.

3. I/O Control Register

3.1 How to Find the I/O Address

The plug & play BIOS will assign a proper I/O address to every PIO/PISO series card in the power-up stage. The fixed IDs of PIO/PISO series card are given as following:

- **Vendor ID = E159**
- **Device ID = 0002**

The sub IDs of **PIO-DA16/8/4** are given as following:

- **Sub-vendor ID= 80**
- **Sub-device ID = 04**
- **Sub-aux ID = 00**

We provide all necessary functions as follows:

1. **PIO_DriverInit(&wBoard, wSubVendor, wSubDevice, wSubAux)**
2. **PIO_GetConfigAddressSpace(wBoardNo,*wBase,*wIrq, *wSubVendor, *wSubDevice, *wSubAux, *wSlotBus, *wSlotDevice)**
3. **Show_PIO_PISO(wSubVendor, wSubDevice, wSubAux)**

All functions are defined in PIO.H. Refer to Chapter 4 for more information. The important driver information is given as follows:

1. Resource-allocated information:

- wBase : BASE address mapping in this PC
- wIrq: IRQ channel number allocated in this PC

2. PIO/PISO identification information:

- wSubVendor: subVendor ID of this board
- wSubDevice: subDevice ID of this board
- wSubAux: subAux ID of this board

3. PC's physical slot information:

- wSlotBus: hardware slot ID1 in this PC's slot position
- wSlotDevice: hardware slot ID2 in this PC's slot position

The utility program, **PIO_PISO.EXE**, will detect & show all PIO/PISO cards installed in this PC. Refer to Sec. 4.1 for more information.

3.1.1 PIO_DriverInit

PIO_DriverInit(&wBoards, wSubVendor, wSubDevice, wSubAux)

- wBoards=0 to N → number of boards found in this PC
- wSubVendor → subVendor ID of board to find
- wSubDevice → subDevice ID of board to find
- wSubAux → subAux ID of board to find

This function can detect all PIO/PISO series card in the system. It is implemented based on the PCI plug & play mechanism-1. It will find all PIO/PISO series cards installed in this system & save all their resource in the library.

Sample program 1: find all PIO-DA16/8/4 in this PC

```
wSubVendor=0x80; wSubDevice=4; wSubAux=0x00; /* for PIO_DA16/8/4 */
wRetVal=PIO_DriverInit(&wBoards, wSubVendor, wSubDevice, wSubAux);
printf("Threr are %d PIO-DA16 Cards in this PC\n", wBoards);

/* step2: save resource of all PIO-DA16/8/4 cards installed in this PC */
for (i=0; i<wBoards; i++)
{
    PIO_GetConfigAddressSpace(i, &wBase, &wIrq, &wID1, &wID2, &wID3, &wID4,
        &wID5);
    printf("\nCard_%d: wBase=%x, wIrq=%x", i, wBase, wIrq);
    wConfigSpace[i][0]=wBaseAddress; /* save all resource of this card */
    wConfigSpace[i][1]=wIrq; /* save all resource of this card */
}
```

Sample program 2: find all PIO/PISO in this PC (refer to Sec. 4.1 for more information)

```
wRetVal=PIO_DriverInit(&wBoards, 0xff, 0xff, 0xff); /*find all PIO_PISO*/
printf("\nThrer are %d PIO_PISO Cards in this PC", wBoards);
if (wBoards==0 ) exit(0);

printf("\n-----");
for(i=0; i<wBoards; i++)
{
    PIO_GetConfigAddressSpace(i, &wBase, &wIrq, &wSubVendor,
        &wSubDevice, &wSubAux, &wSlotBus, &wSlotDevice);

    printf("\nCard_%d: wBase=%x, wIrq=%x, subID=[%x, %x, %x],
        SlotID=[%x, %x]", i, wBase, wIrq, wSubVendor, wSubDevice,
        wSubAux, wSlotBus, wSlotDevice);
    printf(" --> ");
    ShowPioPiso(wSubVendor, wSubDevice, wSubAux);
}
```

The sub-IDs of PIO/PISO series card are given as follows:

PIO/PISO series card	Description	Sub_vendor	Sub_device	Sub_AUX
PIO-D144	144 * D/I/O	80	01	00
PIO-D96	96 * D/I/O	80	01	10
PIO-D64	64 * D/I/O	80	01	20
PIO-D56	24* D/I/O + 16*D/I + 16*D/O	80	01	40
PIO-D48	48*D/I/O	80	01	30
PIO-D24	24*D/I/O	80	01	40
PIO-823	Multi-function	80	03	00
PIO-821	Multi-function	80	03	10
PIO-DA16	16*D/A	80	04	00
PIO-DA8	8*D/A	80	04	00
PIO-DA4	4*D/A	80	04	00
PISO-C64	64 * isolated D/O	80	08	00
PISO-P64	64 * isolated D/I	80	08	10
PISO-P32C32	32 + 32	80	08	20
PISO-P8R8	8* isolated D/I + 8 * 220V relay	80	08	30
PISO-P8SSR8AC	8* isolated D/I + 8 * SSR /AC	80	08	30
PISO-P8SSR8DC	8* isolated D/I + 8 * SSR /DC	80	08	30
PISO-730	16*DI + 16*D/O + 16* isolated D/I + 16* isolated D/O	80	08	40
PISO-813	32 * isolated A/D	80	0A	00
PISO-DA2	2 * isolated D/A	80	0B	00

Note: the sub-IDs will be added more & more without notice. The user can refer to PIO.H for the newest information.

3.1.2 PIO_GetConfigAddressSpace

**PIO_GetConfigAddressSpace(wBoardNo,*wBase,*wIrq, *wSubVendor,
*wSubDevice,*wSubAux,*wSlotBus, *wSlotDevice)**

- wBoardNo=0 to N → totally N+1 boards found by PIO_DriveInit(...)
- wBase → base address of the board control word
- wIrq → allocated IRQ channel number of this board
- wSubVendor → subVendor ID of this board
- wSubDevice → subDevice ID of this board
- wSubAux → subAux ID of this board
- wSlotBus → hardware slot ID1 of this board
- wSlotDevice → hardware slot ID2 of this board

The user can use this function to save resource of all PIO/PISO cards installed in this system. Then the application program can control all functions of PIO/PISO series card directly.

The sample program source is given as follows:

```
/* step1: detect all PIO-DA16/8/4 cards first */
wSubVendor=0x80; wSubDevice=4; wSubAux=0x00; /* for PIO_DA16/8/4 */
wRetVal=PIO_DriverInit(&wBoards, wSubVendor,wSubDevice,wSubAux);
printf("Threr are %d PIO-DA16/8/4 Cards in this PC\n",wBoards);

/* step2: save resource of all PIO-DA16/8/4 cards installed in this PC */
for (i=0; i<wBoards; i++)
{
PIO_GetConfigAddressSpace(i,&wBase,&wIrq,&t1,&t2,&t3,&t4,&t5);
printf("\nCard_ %d: wBase=%x, wIrq=%x", i,wBase,wIrq);
wConfigSpace[i][0]=wBaseAddress; /* save all resource of this card */
wConfigSpace[i][1]=wIrq; /* save all resource of this card */
}

/* step3: control the PIO-DA16/8/4 directly */
wBase=wConfigSpace[0][0];/* get base address the card_0 */
output(wBase,1); /* enable all D/I/O operation of card_0 */

wBase=wConfigSpace[1][0];/* get base address the card_1 */
output(wBase,1); /* enable all D/I/O operation of card_1 */
```

3.1.3 Show_PIO_PISO

Show_PIO_PISO(wSubVendor,wSubDevice,wSubAux)

- wSubVendor → subVendor ID of board to find
- wSubDevice → subDevice ID of board to find
- wSubAux → subAux ID of board to find

This function will show a text string for this special subIDs. This text string is the same as that defined in PIO.H

The demo program is given as follows:

```
wRetVal=PIO_DriverInit(&wBoards,0xff,0xff,0xff); /*find all PIO_PISO*/
printf("\nThrer are %d PIO_PISO Cards in this PC",wBoards);
if (wBoards==0 ) exit(0);

printf("\n-----");
for(i=0; i<wBoards; i++)
{
    PIO_GetConfigAddressSpace(i,&wBase,&wIrq,&wSubVendor,
        &wSubDevice,&wSubAux,&wSlotBus,&wSlotDevice);

    printf("\nCard_%d:wBase=%x,wIrq=%x,subID=[%x,%x,%x],
        SlotID=[%x,%x]",i,wBase,wIrq,wSubVendor,wSubDevice,
        wSubAux,wSlotBus,wSlotDevice);
    printf(" --> ");
    ShowPioPiso(wSubVendor,wSubDevice,wSubAux);
}
```

3.2 The Assignment of I/O Address

The plug & play BIOS will assign the proper I/O address to PIO/PISO series card. If there is only one PIO/PISO board, the user can identify the board as card_0. If there are two PIO/PISO boards in the system, the user will be very difficult to identify which board is card_0 ? The software driver can support 16 boards max. Therefore the user can install 16 boards of PIO/PSIO series in one PC system. How to find the card_0 & card_1 ?

It is difficult to find the card NO. The simplest way to identify which card is card_0 is to use wSlotBus & wSlotDevice as following:

1. Remove all PIO-DA16/8/4 from this PC
2. Install one PIO-DA16/8/4 into the PC's PCI_slot1, run PIO_PISO.EXE & record the wSlotBus1 & wSlotDevice1
3. Remove all PIO-DA16/8/4 from this PC
4. Install one PIO-DA16/8/4 into the PC's PCI_slot2, run PIO_PISO.EXE & record the wSlotBus2 & wSlotDevice2
5. repeat (3) & (4) for all PCI_slot?, record all wSlotBus? & wSlotDevice?

The records may be as follows:

PC's PCI slot	WslotBus	WSlotDevice
Slot_1	0	0x07
Slot_2	0	0x08
Slot_3	0	0x09
Slot_4	0	0x0A
PCI-BRIDGE		
Slot_5	1	0x0A
Slot_6	1	0x08
Slot_7	1	0x09
Slot_8	1	0x07

The above procedure will record all wSlotBus? & wSlotDevice? in this PC. These values will be mapped to this PC's physical slot. This mapping will not be changed for any PIO/PISO cards. So it can be used to identify the specified PIO/PISO card as following:

Step 1: Record all wSlotBus? & wSlotDevice?

Step2: Use PIO_GetConfigAddressSpace(...) to get the specified card's wSlotBus & wSlotDevice

Step3: The user can identify the specified PIO/PISO card if he compare the wSlotBus & wSlotDevice in step2 to step1.

3.3 The I/O Address Map

The I/O address of PIO/ PISO series card are automatically assigned by the main board ROM BIOS. The I/O address can also be re-assigned by user. **It is strongly recommended not to change the I/O address by user. The plug & play BIOS will assign proper I/O address to each PIO/PISO series card very well.** The I/O address of PIO-DA16/8/4 are given as follows:

Address	Read	Write
wBase+0	RESET\ control register	Same
wBase+2	Aux control register	Same
wBase+3	Aux data register	Same
wBase+5	INT mask control register	Same
wBase+7	Aux pin status register	Same
wBase+0x2a	INT polarity control register	Same
wBase+0xc0	Read 8254-counter0	Write 8254-counter0
wBase+0xc4	Read 8254-counter1	Write 8254-counter1
wBase+0xc8	Read 8254-counter2	Write 8254-counter2
wBase+0xcc	Read 8254 control word	Write 8254 control word
wBase+0xe0	Read low byte of D/I	DA_0 chip select
wBase+0xe4	Read high byte of D/I	DA_1 chip select
wBase+0xe8	Read low byte of D/I	DA_2 chip select
wBase+0xec	Read high byte of D/I	DA_3 chip select
wBase+0xf0	Read low byte of D/I	Write low byte of D/A
wBase+0xf4	Read high byte of D/I	Write high byte of D/A
wBase+0xf8	Read low byte of D/I	Write low byte of D/O
wBase+0xfc	Read high byte of D/I	Write high byte of D/O

Note. Refer to Sec. 3.1 for more information about wBase.

3.3.1. RESET\ Control Register

(Read/Write): wBase+0

Bit 7	Bit 6	Bit 5	Bit 4	Bit 3	Bit 2	Bit 1	Bit 0
Reserved	Reserved	0	1	Reserved	Reserved	Reserved	Disable\ Enable

Note. Refer to Sec. 3.1 for more information about wBase.

When the PC is first power-up, the Disable\Enable signal is in Low-state. **This will disable all D/I/O operations.** The user has to set the Disable\Enable signal to High-state before any D/I/O command.

The combination of bit5 and bit4 control the PIB cycle operation for DAC. To enable the PIO-DA16/8/4 with DAC operation, we should write 0x11 into this register.

```
outportb(wBase,11); /* all D/I/O are enable and DAC are enable now */  
outportb(wBase,10); /* all D/I/O are disable and DAC are enable now */
```

3.3.2 AUX Control Register

(Read/Write): wBase+2

Bit 7	Bit 6	Bit 5	Bit 4	Bit 3	Bit 2	Bit 1	Bit 0
Aux7	Aux6	Aux5	Aux4	Aux3	Aux2	Aux1	Aux0

Note. Refer to Sec. 3.1 for more information about wBase.

Aux?=0 → this Aux is used as a D/I

Aux?=1 → this Aux is used as a D/O

When the PC is first power-on, All Aux? signal are in Low-state. All Aux? are designed as D/I for all PIO/PISO series. Please set all Aux? in D/I state.

3.3.3 AUX data Register

(Read/Write): wBase+3

Bit 7	Bit 6	Bit 5	Bit 4	Bit 3	Bit 2	Bit 1	Bit 0
Aux7	Aux6	Aux5	Aux4	Aux3	Aux2	Aux1	Aux0

Note. Refer to Sec. 3.1 for more information about wBase.

When the Aux? is used as D/O, the output state is controlled by this register. This register is designed for feature extension, so don't control this register now.

3.3.4 INT Mask Control Register

(Read/Write): wBase+5

Bit 7	Bit 6	Bit 5	Bit 4	Bit 3	Bit 2	Bit 1	Bit 0
0	0	0	0	0	0	EN1	EN0

Note. Refer to Sec. 3.1 for more information about wBase.

EN0=0 → disable INT0 as a interrupt signal (default)

EN0=1 → enable INT0 as a interrupt signal

EN1=0 → disable INT1 as a interrupt signal (default)

EN1=1 → enable INT1 as a interrupt signal

```
outportb(wBase+5,0);    /* disable all interrupts */
outportb(wBase+5,1);    /* enable interrupt of INT0 */
outportb(wBase+5,2);    /* enable interrupt of INT1 */
outportb(wBase+5,3);    /* enable all two channels of interrupt */
```

Refer to the following demo program for more information:

DEMO3.C & DEMO4.C → single interrupt source

DEMO5.C & DEMO6.C → multi interrupt source

3.3.5 Aux Status Register

(Read/Write): wBase+7

Bit 7	Bit 6	Bit 5	Bit 4	Bit 3	Bit 2	Bit 1	Bit 0
Aux7	Aux6	Aux5	Aux4	Aux3	Aux2	Aux1	Aux0

Note. Refer to Sec. 3.1 for more information about wBase.

Aux0=INT0, Aux1=INT1, Aux2~3=control EEPROM, Aux7~4=Aux-ID. Refer to Sec. 4.1 for more information. The Aux 0~1 are used as interrupt sources. The interrupt service routine has to read this register for interrupt source identification. Refer to Sec. 2.3 for more information.

3.3.6 Interrupt Polarity Control Register

(Read/Write): wBase+0x2A

Bit 7	Bit 6	Bit 5	Bit 4	Bit 3	Bit 2	Bit 1	Bit 0
0	0	0	0	×	×	INV1	INV0

Note. Refer to Sec. 3.1 for more information about wBase.

INV0/1=0 → select the inverted signal from INT0/1

INV0/1=1 → select the non-inverted signal from INT0/1

```
outportb(wBase+0x2a,0); /* select the inverted input from all 2 channels */
```

```
outportb(wBase+0x2a,3); /* select the non-inverted input from all 2 channels */
```

```
outportb(wBase+0x2a,2); /* select the inverted input of INT0 */
```

```
/* select the non-inverted input from the others */
```

Refer to Sec. 2.3 for more information.

Refer to DEMO3/4/5/6.C for more information.

3.3.7 Digital Input

(Read): wBase+0xf8 → Low byte of D/I port

Bit7	Bit6	Bit5	Bit4	Bit3	Bit2	Bit1	Bit0
DI7	DI6	DI5	DI4	DI3	DI2	DI1	DI0

(Read): wBase+0xfc → High byte of D/I port

Bit7	Bit6	Bit5	Bit4	Bit3	Bit2	Bit1	Bit0
DI15	DI14	DI13	DI12	DI11	DI10	DI9	DI8

Note. Refer to Sec. 3.1 for more information about wBase.

```
wDiLoByte = inportb(wBase+0xf8);          /* read D/I states (DI 7~DI0) */
wDiHiByte = inportb(wBase+0xfc);          /* read D/I states (DI15~DI8) */
wDiValue = (wDiHiByte<<8)|wDiLoByte;
```

Refer to DEMO2.C for more information.

3.3.8 Digital Output

(Write): wBase+0xf8 → Low byte of D/O port

Bit7	Bit6	Bit5	Bit4	Bit3	Bit2	Bit1	Bit0
DO7	DO6	DO5	DO4	DO3	DO2	DO1	DO0

(Write): wBase+0xfc → High byte of D/O port

Bit7	Bit6	Bit5	Bit4	Bit3	Bit2	Bit1	Bit0
DO15	DO14	DO13	DO12	DO11	DO10	DO9	DO8

Note. Refer to Sec. 3.1 for more information about wBase.

```
outportb(wBase+0xf8,wDoValue);           /* Control the DO state (DO 7~DO0) */
outportb(wBase+0xfc,wDoValue>>8);       /* Control the DO state (DO15~DO8) */
```

Refer to DEMO1/2.C for more information.

3.3.9 Read/Write 8254

(Read/Write): wBase+0xc0=8254-counter-0

(Read/Write): wBase+0xc4=8254-counter-1

(Read/Write): wBase+0xc8=8254-counter-2

(Read/Write): wBase+0xcc=8254 control word

8254 control word

SC1	SC0	RL1	RL0	M2	M1	M0	BCD
-----	-----	-----	-----	----	----	----	-----

BCD: 0: binary count 1: BCD count

M2,M1,M0: 000:mode0 interrupt on terminal count
001:mode1 programmable one-shot
010:mode2 rate generator
011:mode3 square-wave generator
100:mode4 software triggered pulse
101:mode5 hardware triggered pulse

RL1,RL0: 00: counter latch instruction
01: read/write low counter byte only
10: read/write high counter byte only
11: read/write low counter byte first, then high counter byte

SC1,SC0: 00: counter0
01: counter1
10: counter2
11: read -back command

```
WORD pio_da16_c0(char cConfig, char cLow, char cHigh)/*COUNTER_0 */
{
    outportb(wBase+0xcc,cConfig);
    outportb(wBase+0xc0,cLow);
    outportb(wBase+0xc0,cHigh);
    return(NoError);
}
WORD pio_da16_c1(char cConfig, char cLow, char cHigh)/*COUNTER_1 */
{
    outportb(wBase+0xcc,cConfig);
    outportb(wBase+0xc4,cLow);
    outportb(wBase+0xc4,cHigh);
    return(NoError);
}
WORD pio_da16_c2(char cConfig, char cLow, char cHigh)/*COUNTER_2 */
{
    outportb(wBase+0xcc,cConfig);
    outportb(wBase+0xc8,cLow);
    outportb(wBase+0xc8,cHigh);
    return(NoError);
}
```

3.3.10 D/A Select

There are 4/2/1 D/A converters in PIO-DA16/8/4 card. It is necessary to select which D/A converter is desired after D/A data had be sent. D/A channels allocate as follows:

Write	A1	A0	
WBase+0xe0 DA_0	0	0	D/A output channel 0
	0	1	D/A output channel 1
	1	0	D/A output channel 2
	1	1	D/A output channel 3
Wbase+0xe4 DA_1	0	0	D/A output channel 4
	0	1	D/A output channel 5
	1	0	D/A output channel 6
	1	1	D/A output channel 7
Wbase+0xe8 DA_2	0	0	D/A output channel 8
	0	1	D/A output channel 9
	1	0	D/A output channel10
	1	1	D/A output channel11
Wbase+0xec DA_3	0	0	D/A output channel12
	0	1	D/A output channel13
	1	0	D/A output channel14
	1	1	D/A output channel15

Note: Refer to Sec.3.3.11 for more information about A1, A0

```

outportb(wBase+0xf0,wDaValue);          /* output low byte of D/A data */
outportb(wBase+0xf4,(wDaValue>>8)|0x02); /* output high byte of D/A data and */
                                          /* select channel 2 on this converter */
outportb(wBase+0xe0,0);                 /* select DA_0 */
                                          /* after this procedure wDaValue will */
                                          /* be sent to channel_2 */

```

Refer to DEMO6.C, DEMO7.C, DEMO8.C and DEMO9.C for more information.

3.3.11 D/A Data Output

(write):wBase+0xf0

Bit7	Bit6	Bit5	Bit4	Bit3	Bit2	Bit1	Bit0
D7	D6	D5	D4	D3	D2	D1	D0

(write):wBase+0xf4

Bit7	Bit6	Bit5	Bit4	Bit3	Bit2	Bit1	Bit0
A1	A0	D13	D12	D11	D10	D9	D8

Note: Refer to Sec.3.3.10 For more information about A1,A2

Each D/A converter has four channels analog output. When write data to D/A converter has to indicate which channel is desire by A1 and A0.

D/A programming sequence:

1. Send data to D/A converter. (This data will be buffered)
2. Select D/A converter. (Start convert)

```
outputb(wBase+0xf0,wDaValue);          /* output low byte of D/A data */
outputb(wBase+0xf4,(wDaValue>>8)|0x02); /* output high byte of D/A data and */
                                          /* select channel 2 on this converter */
outputb(wBase+0xe0,0);                  /* select DA_0 */
                                          /* after this procedure wDaValue will */
                                          /* be sent to channel_2 */

pio_da16_da(2,wDaValue);                /* send wDaValue to channel_2 */

void pio_da16_da(char cChannel_no,int iVal)
{
iVal=iVal+(cChannel_no%4)*0x4000;      /* cChannel_no : 0 - 15 */
outputb(wBase+0xf0,iVal);               /* iVal : 0x0000 - 0x3fff */
outputb(wBase+0xf4,(iVal>>8));
outputb(wBase+0xe0+4*(cChannel_no/4),0xff);
}
```

Refer to DEMO6.C, DEMO7.C, DEMO8.C and DEMO9.C for more information.

4. Demo Program

It is recommended to read the release note first. All importance information will be given in release note as follows:

1. where you can find the software driver & utility
- 2. how to install software & utility**
3. where is the diagnostic program
4. FAQ

There are many demo programs given in the company floppy disk or CD. After the software installation, the driver will be installed into disk as follows:

- \TC*. * → for Turbo C 2.xx or above
- \MSC*. * → for MSC 5.xx or above
- \BC*. * → for BC 3.xx or above

- \TC\LIB*. * → for TC library
- \TC\DEMO*. * → for TC demo program

- \TC\LIB\Large*. * → TC large model library
- \TC\LIB\Huge*. * → TC huge model library
- \TC\LIB\Large\PIO.H → TC declaration file
- \TC\LIB\Large\TCPIO_L.LIB → TC large model library file
- \TC\LIB\Huge\PIO.H → TC declaration file
- \TC\LIB\Huge\TCPIO_H.LIB → TC huge model library file

- \MSC\LIB\Large\PIO.H → MSC declaration file
- \MSC\LIB\Large\MSCPIO_L.LIB → MSC large model library file
- \MSC\LIB\Huge\PIO.H → MSC declaration file
- \MSC\LIB\Huge\MSCPIO_H.LIB → MSC huge model library file

- \BC\LIB\Large\PIO.H → BC declaration file
- \BC\LIB\Large\BCPIO_L.LIB → BC large model library file
- \BC\LIB\Huge\PIO.H → BC declaration file
- \BC\LIB\Huge\BCPIO_H.LIB → BC huge model library file

NOTE: The library is validate for all PIO/PISO series cards.

Demo program list :

DEMO1.EXE: D/O demo program

DEMO2.EXE: D/I/O demo program

DEMO3.EXE: Single interrupt source (initial high)

DEMO4.EXE: Single interrupt source (initial low)

DEMO5.EXE: Two interrupt source

DEMO6.EXE: Waveform generator without calibration

DEMO7.EXE: Waveform generator with calibration

DEMO8.EXE: D/A hex value output without calibration

DEMO9.EXE: D/A hex value output with calibration

DEMO10.EXE: Save EEPROM data to file

DEMO11.EXE: Download EEPROM data from file

DEMO12.EXE: User software calibration

DEMO13.EXE: Factory calibration

Note: Some demo programs do not list in this manual. Please refer to company floppy disk or CD.

4.1 PIO_PISO

```
/* ----- */
/* Find all PIO_PISO series cards in this PC system */
/* step 1 : plug all PIO_PISO cards into PC */
/* step 2 : run PIO_PISO.EXE */
/* ----- */

#include "PIO.H"

WORD wBase,wIrq;
WORD wBase2,wIrq2;

int main()
{
int i,j,j1,j2,j3,j4,k,jj,dd,j11,j22,j33,j44;
WORD wBoards,wRetVal;
WORD wSubVendor,wSubDevice,wSubAux,wSlotBus,wSlotDevice;
char c;
float ok,err;

clrscr();
wRetVal=PIO_DriverInit(&wBoards,0xff,0xff,0xff); /*for PIO-PISO*/
printf("\nThrer are %d PIO_PISO Cards in this PC",wBoards);
if (wBoards==0 ) exit(0);

printf("\n-----");
for(i=0; i<wBoards; i++)
{
PIO_GetConfigAddressSpace(i,&wBase,&wIrq,&wSubVendor,
&wSubDevice,&wSubAux,&wSlotBus,&wSlotDevice);

printf("\nCard_%d:wBase=%x,wIrq=%x,subID=[ %x,%x,%x],
SlotID=[ %x,%x]",i,wBase,wIrq,wSubVendor,wSubDevice,
wSubAux,wSlotBus,wSlotDevice);
printf(" --> ");
ShowPioPiso(wSubVendor,wSubDevice,wSubAux);
}

PIO_DriverClose();
}
```

NOTE: the PIO_PISO.EXE is valid for all PIO/PISO cards. The user can execute the PIO_PISO.EXE to get the following information:

- List all PIO/PISO cards installed in this PC
 - List all resources allocated to every PIO/PISO cards
 - List the wSlotBus & wSlotDevice for specified PIO/PISO card identification.
- (Refer to Sec. 3.2 for more information)

4.1.1 PIO_PISO.EXE for Windows

User can find this utility in the company CD or floppy disk. It is useful for all PIO/PISO series card.

After executing the utility, every detail information for all PIO/PISO cards that installed in the PC will be show as follows:



4.2 DEMO1

```
/* DEMO1 : D/O demo for PIO-DA16/8/4 */
/* step1 : Run DEMO1.EXE */
/* step2 : Check the LEDs of DB-24C will turn on sequentially */
/* ----- */
#include "PIO.H"
void pio_da16_do(WORD wDo);
WORD wBase,wIrq;
int main()
{
int i,j;
WORD wBoards,wRetVal,t1,t2,t3,t4,t5,t6;
WORD wSubVendor,wSubDevice,wSubAux,wSlotBus,wSlotDevice;
clrscr();

/* step1 : find address-mapping of PIO/PISO cards */
wRetVal=PIO_DriverInit(&wBoards,0x80,0x04,0x00);/*for PIO-DA16/8/4*/
printf("\n(1) Threr are %d PIO-DA16/8/4 Cards in this PC",wBoards);
if ( wBoards==0 ) exit(0);

printf("\n\n----- The Configuration Space -----");
for(i=0;i<wBoards;i++)
{
PIO_GetConfigAddressSpace(i,&wBase,&wIrq,&wSubVendor,&wSubDevice,
&wSubAux,&wSlotBus,&wSlotDevice);

printf("\nCard_%d: wBase=%x,wIrq=%x,subID=[%x,%x,%x],
SlotID=[%x,%x]",i,wBase,wIrq,wSubVendor,wSubDevice,wSubAux,
wSlotBus,wSlotDevice);

printf(" --> ");
ShowPioPiso(wSubVendor,wSubDevice,wSubAux);
}

PIO_GetConfigAddressSpace(0,&wBase,&wIrq,&t1,&t2,&t3,&t4,&t5);
/* select card_0 */
/* step2 : enable all D/I/O port */
outportb(wBase,1); /* /RESET -> 1 */
printf("\n\n(2) DEMO1 D/O test");
j=1;
for(;;)
{
gotoxy(1,8);
pio_da16_do(j);
printf("\nDO ==> %4x",j);
delay(10000);
if (kbhit()!=0) break;
j=j<<1; j=j&0x0ffff;if (j==0) j=1;
}
PIO_DriverClose();
}
/* ----- */
void pio_da16_do(WORD wDo)
{
outportb(wBase+0xf8,wDo); /* 0xf8 : low byte of DO port */
outportb(wBase+0xfc,(wDo>>8)); /* 0xfc : high byte of DO port */
}
}
```

4.3 DEMO2

```
/* DEMO2 : D/I/O demo for PIO-DA16/8/4 */
/* step1 : Connect CON1 & CON2 with a 20-pin 1 to 1 flot cable */
/* step2 : Run DEMO2.EXE */
```

```

/* ----- */
#include "PIO.H"

void pio_da16_di(WORD *wDi);
void pio_da16_do(WORD wDo);
WORD wBase,wIrq;

int main()
{
int i,j,k;
WORD wBoards,wRetVal,t1,t2,t3,t4,t5,t6;
WORD wSubVendor,wSubDevice,wSubAux,wSlotBus,wSlotDevice;

clrscr();

/* step1 : find address-mapping of PIO/PISO cards */
.
.
/* step2 : enable all D/I/O port */
outportb(wBase,1); /* /RESET -> 1 */

printf("\n\n(2) DEMO2 D/I/O test");
j=1;
for(;;)
{
pio_da16_do(j);
pio_da16_di(&k);
gotoxy(1,9);
printf("DO = %4x , DI = %4x",j,k);
if (k!=j) printf(" <-- Test Error ");
else printf(" <-- Test Ok ");
j++; j=j&0xffff;if (j==0) j=1;
if (kbhit()!=0) break;
}
PIO_DriverClose();
}
/* ----- */
void pio_da16_di(WORD *wDi)
{
int in_l,in_h;
in_l=inportb(wBase+0xe0)&0xff;
in_h=inportb(wBase+0xe4)&0xff;
(*wDi)=(in_h<<8)+in_l;
}
/* ----- */
void pio_da16_do(WORD wDo)
{
outportb(wBase+0xf8,wDo); /* 0xf8 : low byte of DO port */
outportb(wBase+0xfc,(wDo>>8)); /* 0xfc : high byte of DO port */
}
}

```

4.4 DEMO3

```
/* DEMO3 : INT_CHAN_1, timer interrupt demo (initial high) */
/*          (It is designed to be a machine independent timer) */
/* step1 : Run DEMO3.EXE */
/* ----- */
#include "PIO.H"
#define A1_8259 0x20
#define A2_8259 0xA0
static void interrupt irq_service();
void pio_da16_c0(char cConfig, char cLow, char cHigh);
void pio_da16_c1(char cConfig, char cLow, char cHigh);
void pio_da16_c2(char cConfig, char cLow, char cHigh);
void init_int1_high();
WORD wBase,wIrq;
int COUNT_L,COUNT_H,irqmask,now_int_state;
int main()
{
    int i,j;
    WORD wBoards,wRetVal,t1,t2,t3,t4,t5,t6;
    WORD wSubVendor,wSubDevice,wSubAux,wSlotBus,wSlotDevice;
    clrscr();
    /* step1 : find address-mapping of PIO/PISO cards */
    .
    .
    /* step2 : enable all D/I/O port */
    outportb(wBase,1); /* /RESET -> 1 */
    printf("\n\n(2) DEMO3 Interrupt (1Hz) test");
    init_int1_high(); /* interrupt initialize, INT1 is high now */
    COUNT_L=0;COUNT_H=0;
    printf("\n\n*** Show the count of Low_pulse ***\n");
    for (;;)
    {
        gotoxy(1,10);
        printf("\nINT count = %d",COUNT_L);
        if (kbhit()!=0) break;
    }
    outportb(wBase+5,0); /* disable all interrupt */
    PIO_DriverClose();
}
/* Use INT_CHAN_1 as internal interrupt signal */
void init_int1_high()
{
    DWORD dwVal;
    disable();
    outportb(wBase+5,0); /* disable all interrupt */
    if (wIrq<8)
    {
        irqmask=inportb(A1_8259+1);
        outportb(A1_8259+1,irqmask & (0xff ^ (1 << wIrq)));
        setvect(wIrq+8, irq_service);
    }
    else
    {
        irqmask=inportb(A1_8259+1);
        outportb(A1_8259+1,irqmask & 0xfb); /* IRQ2 */
        irqmask=inportb(A2_8259+1);
        outportb(A2_8259+1,irqmask & (0xff ^ (1 << (wIrq-8))));
        setvect(wIrq-8+0x70, irq_service);
    }
}
/* CLK source = 4 MHz */
pio_da16_c1(0x76,0x90,0x01); /* COUNTER1, mode3, div 400 */
pio_da16_c2(0xb6,0x10,0x27); /* COUNTER2, mode3, div 10000 */
/* program Cout2 1Hz */
```

```

/* note : the 8254 need extra 2-clock for initialization */
for (;;)
{
    if ((inportb(wBase+7)&2)==2) break; /* wait Cout2 = high */
}
/* note : Cout2 = high, INV1 must select the inverted Cout2 */
/* --> INT_CHAN_1 = !Cout2 = init_low, active_high */
outportb(wBase+0x2a,0); /* INV1 = 0, inverted Cout2 */

now_int_state=1; /* now Cout2 is high */
outportb(wBase+5,2); /* EN1 = 1, enable INT_CHAN_1 */
/* as interrupt source */
enable();
}
/* ----- */
void interrupt irq_service()
{
    if (now_int_state==1) /* now INT1(Cout2) changed to low */
    { /* --> INT_CHAN_1=!INT1=high now */
        COUNT_L++; /* find a low pulse (INT1) */
        if((inportb(wBase+7)&2)==0) /* INT1 is still fixed in low -> */
        { /* need to generate a high pulse */
            outportb(wBase+0x2a,2); /* INV1 select non-inverted input */
            /* INT_CHAN_1=INT1=low --> */
            /* INT_CHAN_1 generate high pulse */
            now_int_state=0; /* now INT1=low */
        }
        else now_int_state=1; /* now INT1=high */
        /* don't have to gen. high pulse */
    }
    else /* now INT1(Cout2) changed to high */
    { /* --> INT_CHAN_1=INT1=high now */
        COUNT_H++; /* find a low pulse (INT1) */
        if((inportb(wBase+7)&2)==2) /* INT1 is still fixed in high -> */
        { /* need to generate a high pulse */
            outportb(wBase+0x2a,0); /* INV1 select inverted input */
            /* INT_CHAN_1=!INT1=low --> */
            /* INT_CHAN_1 generate high_pulse */
            now_int_state=1; /* now INT1=high */
        }
        else now_int_state=0; /* now INT1=low */
        /* don't have to gen. high pulse */
    }
}
if (wIrq>=8) outportb(A2_8259,0x20);
outportb(A1_8259,0x20);
}
/* ----- */
void pio_da16_c0(char cConfig, char cLow, char cHigh) /* COUNTER0 */
{
    outportb(wBase+0xcc,cConfig);
    outportb(wBase+0xc0,cLow);
    outportb(wBase+0xc0,cHigh);
}

```

4.5 DEMO5

```
/* DEMO5 : INT_CHAN_0 & INT_CHAN_1 timer interrupt demo          */
/*           (It is designed to be a machine independent timer)  */
/* step1 : Run DEMO5.EXE                                         */
/* ----- */
#include "PIO.H"
#define A1_8259 0x20
#define A2_8259 0xA0
static void interrupt irq_service();
WORD wBase,wIrq;
int  irqmask,now_int_state,new_int_state,int_c;
int  INT0_L,INT0_H,INT1_L,INT1_H;
int  b0,b1,invert;
int  main()
{
  int  i,j;
  WORD  wBoards,wRetVal,t1,t2,t3,t4,t5,t6;
  WORD  wSubVendor,wSubDevice,wSubAux,wSlotBus,wSlotDevice;
  clrscr();
  /* step1 : find address-mapping of PIO/PISO cards              */
  .
  .
  /* step2 : enable all D/I/O port                               */
  outportb(wBase,1);                                           /* /RESET -> 1 */
  printf("\n\n(2) DEMO5 Interrupt test");
  init_high(); /* interrupt initialize, INT_CHAN_0/1 is high now */
  printf("\n\n*** Show the count of Low_pulse ***\n");
  INT0_L=INT0_H=INT1_L=INT1_H=0;
  for (;;)
  {
    gotoxy(1,10);
    printf("\nINT0[%x,%x],INT1[%x,%x]",INT0_H,INT0_L,INT1_H,INT1_L);
    if (kbhit()!=0) break;
  }
  outportb(wBase+5,0); /* disable all interrupt */
  PIO_DriverClose();
}
/* Use INT_CHAN_0 & INT_CHAN_1 as internal interrupt signal    */
void init_high()
{
  DWORD dwVal;
  disable();
  outportb(wBase+5,0); /* disable all interrupt */
  if (wIrq<8)
  {
    irqmask=inportb(A1_8259+1);
    outportb(A1_8259+1,irqmask & (0xff ^ (1 << wIrq)));
    setvect(wIrq+8, irq_service);
  }
  else
  {
    irqmask=inportb(A1_8259+1);
    outportb(A1_8259+1,irqmask & 0xfb); /* IRQ2 */
    irqmask=inportb(A2_8259+1);
    outportb(A2_8259+1,irqmask & (0xff ^ (1 << (wIrq-8))));
    setvect(wIrq-8+0x70, irq_service);
  }
}
/* CLK source = 4 MHz */
pio_da16_c0(0x36,0x20,0x4e); /* COUNTER0, mode3, div 20000 */
/* program Cout0 200Hz */
pio_da16_c1(0x76,0x90,0x01); /* COUNTER1, mode3, div 400 */
pio_da16_c2(0xb6,0x64,0x00); /* COUNTER2, mode3, div 100 */
/* program Cout2 100Hz */
```

```

/* note : the 8254 need extra 2-clock for initialization */
for (;;)
{
    if ((inportb(wBase+7)&3)==3) break; /* wait Cout0&Cout2 = high */
}
/* note : Cout0/2 = high, INV0/1 must select the inverted Cout0/2 */
/* --> INT_CHAN_0 = !Cout0 = init_low, active_high */
/* --> INT_CHAN_1 = !Cout2 = init_low, active_high */
outportb(wBase+0x2a,0); /* INV0=0, INV1=0 inverted */
now_int_state=3; /* now Cout0 & Cout2 is high */
outportb(wBase+5,3); /* enable INT_CHAN_0/1 interrupt */
enable();
}
/* ----- */
/* Note : 1.The hold_time of INT_CHAN_0 & INT_CHAN_1 must long */
/* enough. */
/* 2.The ISR must read the interrupt status again to */
/* identify the active interrupt source. */
/* 3.The INT_CHAN_0 & INT_CHAN_1 can be active at the same */
/* time. */
/* ----- */
void interrupt irq_service()
{
    /* now ISR can not know which interrupt is active */
    new_int_state=inportb(wBase+7)&0x03; /* read all interrupt */
    /* signal state */
    int_c=new_int_state^now_int_state; /* compare new_state to */
    /* old_state */
    if ((int_c&0x01)==1) /* INT_CHAN_0 is active */
    {
        if ((new_int_state&1)==0) /* INT0 change to low now */
        {
            INT0_L++;
        }
        else /* INT0 change to high now */
        {
            INT0_H++;
        }
        invert=invert^1; /* generate high_pulse */
    }
    if ((int_c&0x02)==2) /* INT_CHAN_1 is active */
    {
        if ((new_int_state&2)==0) /* INT1 change to low now */
        {
            INT1_L++;
        }
        else /* INT1 change to high now */
        {
            INT1_H++;
        }
        invert=invert^2; /* generate high_pulse */
    }
    now_int_state=new_int_state; /* update interrupt status */
    outportb(wBase+0x2a,invert); /* generate a high pulse */
    if (wIrq>=8) outportb(A2_8259,0x20);
    outportb(A1_8259,0x20);
}

```

4.6 DEMO8

```
/* DEMO8 : D/A Output without calibration */
/* step1 : Run DEMO8.EXE */
/* ----- */
#include "PIO.H"

void pio_da16_da(int cChannel_no,int iVal);

WORD wBase,wIrq;

int main()
{
int i,j,k;
WORD wBoards,wRetVal,t1,t2,t3,t4,t5,t6;
WORD wSubVendor,wSubDevice,wSubAux,wSlotBus,wSlotDevice;

clrscr();

/* step1 : find address-mapping of PIO/PISO cards */
.
.
/* step2 : enable all D/I/O port */
outportb(wBase,0x11); /* /RESET -> 1 */

printf("\n\n(2) A/D Output without calibration test");

printf("\n\n (a) 1.23V Voltage output to each channel");
for (i=0; i<16; i++)
{
j=1.23*16383/20.0+8192;
pio_da16_da(i,j);
}
getch();
printf("\n\n (b) 1.23mA Current output to each channel");
for (i=0; i<16; i++)
{
j=1.23*8192/20+8191;
pio_da16_da(i,j);
}
getch();

outportb(wBase+5,0); /* disable all interrupt */
outportb(wBase+3,0); /* all D/O are Low */
outportb(wBase+2,0); /* all AUX as D/I */
PIO_DriverClose();
}
/* ----- */
void pio_da16_da(int iChannel_no,int iVal)
{
iVal=iVal+(iChannel_no%4)*0x4000; /* iChannel_no : 0 - 15 */
outportb(wBase+0xf0,iVal); /* iVal : 0x0000 - 0x3fff */
outportb(wBase+0xf4,(iVal>>8));
outportb(wBase+0xe0+4*(iChannel_no/4),0xff);
}
}
```

4.7 DEMO9

```
/* DEMO9 : D/A Output with calibration */
/* step1 : Run DEMO9.EXE */
/* ----- */
#include "PIO.H"
void pio_da16_da(int cChannel_no,int iVal);
WORD wBase,wIrq;
WORD wN10V[16],wP10V[16],w00mA[16],w20mA[16],EEP;
float fDeltaV[16],fDeltaI[16];
int main()
{
int i,j,k;
WORD wBoards,wRetVal,t1,t2,t3,t4,t5,t6;
WORD wSubVendor,wSubDevice,wSubAux,wSlotBus,wSlotDevice;

clrscr();

/* step1 : find address-mapping of PIO/PISO cards */
.
.
/* step2 : enable all D/I/O port */
outportb(wBase,0x11); /* /RESET -> 1 */
outportb(wBase+2,0x1c); /* AUX 4/3/2 are D/O, othes D/I */
outportb(wBase+3,0); /* all D/O are Low */

printf("\n\n(2) A/D Output with calibration test");

for (i=0; i<64;i++)
{
if (i<16)
{
EEP_READ(i,&j,&k);
wN10V[i]=(j<<8)+k;
}
if ((i>=16)&&(i<32))
{
EEP_READ(i,&j,&k);
wP10V[i-16]=(j<<8)+k;
}
if ((i>=32)&&(i<48))
{
EEP_READ(i,&j,&k);
w00mA[i-32]=(j<<8)+k;
}
if (i>=48)
{
EEP_READ(i,&j,&k);
w20mA[i-48]=(j<<8)+k;
}
}

for (i=0; i<16; i++)
{
fDeltaV[i]=20.0/(wP10V[i]-wN10V[i]);
fDeltaI[i]=20.0/(w20mA[i]-w00mA[i]);
}

printf("\n\n (a) 1.23V Voltage output to each channel");
for (i=0; i<16; i++)
{
j=(1.23+10.0)/fDeltaV[i]+wN10V[i];
pio_da16_da(i,j);
}
}
```

```

getch();
printf("\n\n      (b) 1.23mA Current output to each channel");
for (i=0; i<16; i++)
    {
        j=1.23/fDeltaI[i]+w00mA[i];
        pio_da16_da(i,j);
    }
getch();

outportb(wBase+5,0);          /* disable all interrupt */
outportb(wBase+3,0);          /* all D/O are Low      */
outportb(wBase+2,0);          /* all AUX as D/I       */
PIO_DriverClose();
}

```