

# PCI4520/DM7520/DM7540 User's Manual

## Version 1.1

*PCI4520 - High-speed Bus Master Analog Data Acquisition Slot Board for IBM PC AT with PCI bus*

*DM7520 - High-speed Bus Master Analog Data Acquisition PC/104plus Board for PC/104plus stack*

*DM7540 - High-speed Bus Master Analog Data Acquisition PC/104plus Board for PC/104plus stack with McBSPs for DSP communication*

*Confidential*

*RTD USA BME Laboratories*

*EPLD versions:*

*PCI4520 - V.7.*

*DM7520 - V.11.*

*DM7540 - V.11.*

*754010.doc*

*01.11.14 8:53*



**rttd**®  
USA

**Real Time Devices USA, Inc.**

*"Accessing the Analog World"®*



**REAL TIME DEVICES USA, INC.**

103 Innovation Blvd  
State College, PA 16803

Phone: +1-814-234-8087

FAX: +1-814-234-5218

E-mail

sales@rtdusa.com

techsupport@rtdusa.com

web site

<http://www.rtdusa.com>

Revision History

01.11.15 1.0 New  
01.11.27 1.1 with Ver 11 EPLD for free running D/A clock to be software compatible with the previous versions

Publication PCI4520/DM7520/DM7540 V1.0 2001.11.15

Published by:

Real Time Devices USA, Inc.  
103 Innovation Boulevard  
State College, PA 16803

Copyright 2001 by Real Time Devices, Inc.  
All rights reserved  
Printed in U.S.A.

The Real Time Devices USA Logo is a registered trademark of Real Time Devices USA. dspModule, cpuModule, and utilityModule are trademarks of Real Time Devices USA. PC/104 is a registered trademark of PC/104 Consortium. TMS320C62x, VelociTI, and C62x are trademarks of Texas Instruments. All other trademarks appearing in this document are the property of their respective owners.

|   |           |
|---|-----------|
| <b>1. OVERVIEW .....</b>  | <b>10</b> |
| 1.1. ANALOG-TO-DIGITAL CONVERSION.....  | 11        |
| 1.2. DIGITAL-TO-ANALOG CONVERSION.....  | 12        |
| 1.3. TIMER/COUNTERS .....   | 12        |
| 1.4. DIGITAL I/O.....   | 12        |
| 1.5. HIGH-SPEED DIGITAL INPUT .....   | 12        |
| 1.6. SYNCBUS .....  | 13        |
| 1.7. MCBSP MULTI-CHANNEL BUFFERED SERIAL PORT (DM7540 ONLY).....  | 13        |
| 1.8. WHAT COMES WITH YOUR BOARD.....  | 13        |
| 1.9. BOARD ACCESSORIES.....   | 13        |
| 1.10. HARDWARE ACCESSORIES.....   | 13        |
| 1.11. USING THIS MANUAL .....   | 13        |
| 1.12. WHEN YOU NEED HELP .....  | 13        |
| <b>2. INSTALLATION.....</b>   | <b>15</b> |
| 2.1. BOARD INSTALLATION.....  | 15        |
| 2.2. EXTERNAL I/O CONNECTIONS.....  | 16        |
| 2.3. CONNECTING THE ANALOG INPUT PINS.....  | 20        |
| 2.3.1. <i>Ground Referenced Single-Ended (GRSE) input mode</i> .....  | 21        |
| 2.3.2. <i>Non Referenced Single-Ended (NRSE) input mode</i> .....   | 23        |
| 2.3.3. <i>Differential (DIFF) input mode</i> .....  | 24        |
| 2.4. CONNECTING THE ANALOG OUTPUTS.....   | 25        |
| 2.5. CONNECTING THE TIMER/COUNTERS AND DIGITAL I/O.....   | 25        |
| 2.6. CONNECTING THE SYNCBUS.....  | 25        |
| TABLE 2.6.1 .....   | 25        |
| 2.7. CONNECTING THE MCBSP .....   | 26        |
| TABLE 2.6.1 .....   | 26        |
| <b>3. HARDWARE DESCRIPTION .....</b>  | <b>27</b> |
| 3.1. THE OPERATION OF ANALOG INPUT AND HIGH-SPEED DIGITAL INPUT SECTION .....   | 27        |
| 3.1.1. <i>Overall Description</i> .....   | 27        |
| 3.1.2. <i>Channel Gain Latch (CGL) and Channel Gain Table (CGT)</i> .....   | 27        |
| 3.1.3. <i>A/D Converter</i> .....   | 29        |
| 3.1.4. <i>A/D FIFO - Sample Buffer</i> .....  | 30        |
| 3.1.5. <i>Data Transfer</i> .....   | 30        |
| 3.1.6. <i>High-Speed Digital Input section</i> .....  | 31        |
| 3.2. THE OPERATION OF ANALOG OUTPUT.....  | 31        |
| 3.3. TIMER/ COUNTERS .....  | 32        |
| 3.4. DIGITAL I/O.....   | 32        |
| 3.5. SYNCBUS .....  | 32        |
| <b>4. REGISTER ADDRESS SPACES OF PCI4520/DM7520/DM7540 .....</b>  | <b>33</b> |
| 4.1. LOCAL ADDRESS SPACE 0 (LAS0) - RUNTIME AREA .....  | 34        |
| 4.1.1. <i>Local Address Space 0 + 000h: Read Master / Target Only mode jumper (JP1) / Firmware version number - DM7520 Only (Read only)</i> ..... | 37        |
| 4.1.2. <i>Local Address Space 0 + 008h: User Input read / User Output Write (Read/write)</i> .....  | 37        |
| 4.1.3. <i>Local Address Space 0 + 010h: FIFO Status Register / A/D Conversion Start (Read/write)</i> ..   | 39        |
| 4.1.4. <i>Local Address Space 0 + 014h: Software update D/A1 (Write only)</i> .....   | 40        |
| 4.1.5. <i>Local Address Space 0 + 018h: Software update D/A2 (Write only)</i> .....   | 40        |
| 4.1.6. <i>Local Address Space 0 + 024h: Simultaneous Software Update D/A1 and D/A2 (Write only)</i> 40  |           |

|   |    |
|---|----|
| 4.1.7. Local Address Space 0 + 028h: Pacer Clock Software Start trigger / Pacer Clock Software Stop trigger (Read/Write) .....                | 40 |
| 4.1.8. Local Address Space 0 + 02Ch: Pacer and Burst Clock Timer Status Register / Software High-speed Input Sample command (Read/Write)..... | 41 |
| 4.1.9. Local Address Space 0 + 030h: Interrupt Status/Mask Register Read/write) .....   | 42 |
| 4.1.10. Local Address Space 0 + 034h Interrupt Clear Register (Read/Write).....   | 45 |
| 4.1.11. Local Address Space 0 + 038h: Interrupt Overrun Register (Read/Write) .....   | 46 |
| 4.1.12. Local Address Space 0 + 040h, Pacer Clock Counter (Read/Write).....   | 47 |
| 4.1.13. Local Address Space 0 + 044h, Burst Clock Counter (Read/Write).....   | 47 |
| 4.1.14. Local Address Space 0 + 048h, A/D Sample Counter (Read/Write) .....   | 48 |
| 4.1.15. Local Address Space 0 + 04Ch, D/A1 Update Counter (Read/Write).....   | 48 |
| 4.1.16. Local Address Space 0 + 050h, D/A2 Update Counter (Read/Write) .....  | 48 |
| 4.1.17. Local Address Space 0 + 054h, Delay Counter (Read/Write).....   | 49 |
| 4.1.18. Local Address Space 0 + 058h, About Counter (Read/Write).....   | 49 |
| 4.1.19. Local Address Space 0 + 05Ch, DAC Clock Counter (Read/Write).....   | 49 |
| 4.1.20. Local Address Space 0 + 060h, 064h, 068h: User Timer/Counter 0, 1, 2 (Read/Write).....  | 50 |
| 4.1.21. Local Address Space 0 + 06Ch User Timer/Counter control word (Write Only) .....   | 51 |
| 4.1.22. Local Address Space 2 + 070h - Digital I/O chip Port 0, Bit Programmable Port (Read/Write) .....                                      | 51 |
| 4.1.23. Local Address Space 0 + 074h - Digital I/O chip Port 1, Byte Programmable Port (Read/Write) .....                                     | 52 |
| 4.1.24. Local Address Space 0 + 78h - Read/Program Port 0 Direction/ Mask/ Compare Registers (Read/Write) .....                               | 52 |
| 4.1.25. Local Address Space 0 + 07Ch - Read Digital IRQ Status/Program Digital Mode (Read/Write) .....  | 54 |
| 4. 2. LOCAL ADDRESS SPACE 0 (LAS0) - SETUP AREA.....  | 55 |
| 4.2.1. Software Reset of the board - LAS0 + 100h (WriteOnly) .....  | 65 |
| 4.2.2. DMA0 Request Source Select - LAS0 + 104h (WriteOnly).....  | 65 |
| 4.2.3. DMA1 Request Source Select - LAS0 + 108h (WriteOnly).....  | 65 |
| 4.2.4. Reset DMA0 Request machine - LAS0 + 1CCh (WriteOnly).....  | 65 |
| 4.2.5. Reset DMA1 Request machine - LAS0 + 1D0h (WriteOnly) .....   | 65 |
| 4.2.6. A/D Conversion Signal Select - LAS0 + 10Ch (WriteOnly) .....   | 66 |
| 4.2.7. A/D Burst Clock start trigger select - LAS0 + 110h (WriteOnly).....  | 66 |
| 4.2.8. Pacer Clock start trigger select - LAS0 + 114h (WriteOnly) .....   | 67 |
| 4.2.9. Pacer Clock Stop Trigger select - LAS0 + 118h (WriteOnly) .....  | 68 |
| 4.2.10. About Counter Stop Enable - LAS0 + 11Ch (WriteOnly).....  | 69 |
| 4.2.11. Pacer Start Trigger Mode select - LAS0 + 120h (WriteOnly).....  | 69 |
| 4.2.12. Sampling Signal for High Speed Digital Input Select - LAS0 + 124h (WriteOnly).....  | 69 |
| 4.2.13. Clear High Speed Digital Input FIFO - LAS0 + 128h (WriteOnly) .....   | 69 |
| 4.2.14. Clear A/D FIFO - LAS0 + 12Ch (WriteOnly) .....  | 69 |
| 4.2.15. Write ADC channel gain table - LAS0 + 130h (WriteOnly).....   | 70 |
| 4.2.16. Write ADC channel gain latch - LAS0 + 134h (WriteOnly) .....  | 70 |
| 4.2.17. Write Digital table - LAS0 + 138h (WriteOnly) .....   | 71 |
| 4.2.18. Enable Channel Gain Table - LAS0 + 13Ch (WriteOnly).....  | 71 |
| 4.2.19. Enable Digital Table - LAS0 + 140h (WriteOnly).....   | 71 |
| 4.2.20. Table Pause enable - LAS0 + 144h (WriteOnly).....   | 71 |
| 4.2.21. Reset Channel Gain Table - LAS0 + 148h (WriteOnly) .....  | 72 |
| 4.2.22. Clear Channel Gain Table - LAS0 + 14Ch (WriteOnly).....   | 72 |
| 4.2.23. D/A1 output type / range - LAS0 + 150h (WriteOnly).....   | 72 |
| 4.2.24. D/A1 update source - LAS0 + 154h (WriteOnly) .....  | 72 |
| 4.2.25. D/A1 Cycle Mode - LAS0 + 158h (WriteOnly).....  | 72 |
| 4.2.26. Reset D/A1 FIFO - LAS0 + 15Ch (WriteOnly).....  | 72 |
| 4.2.27. Clear D/A1 FIFO - LAS0 + 160h (WriteOnly).....  | 73 |
| 4.2.28. D/A2 output type / range - LAS0 + 164h (WriteOnly).....   | 73 |
| 4.2.29. D/A2 update source - LAS0 + 168h (WriteOnly) .....  | 73 |

|  |           |
|--|-----------|
| 4.2.30. D/A2 Cycle Mode - LAS0 + 16Ch (WriteOnly) .....  | 73        |
| 4.2.31. Reset D/A2 FIFO - LAS0 + 170h (WriteOnly) .....  | 73        |
| 4.2.32. Clear D/A2 FIFO - LAS0 + 174h (WriteOnly) .....  | 73        |
| 4.2.33. A/D Sample Counter Source Select - LAS0 + 178h (WriteOnly) .....   | 74        |
| 4.2.34. Pacer Clock Select - LAS0 + 180h (WriteOnly) .....   | 74        |
| 4.2.35. SyncBus 0 Source Select - LAS0 + 184h (WriteOnly) .....  | 74        |
| 4.2.36. Enable SyncBus 0 - LAS0 + 188h (WriteOnly) .....   | 74        |
| 4.2.37. SyncBus 1 Source Select - LAS0 + 18Ch (WriteOnly) .....  | 75        |
| 4.2.38. Enable SyncBus 1 - LAS0 + 190h (WriteOnly) .....   | 76        |
| 4.2.39. SyncBus 2 Source Select - LAS0 + 198h (WriteOnly) .....  | 76        |
| 4.2.40. Enable SyncBus 2 - LAS0 + 19Ch (WriteOnly) .....   | 76        |
| 4.2.41. External Trigger polarity select - LAS0 + 1A4h (WriteOnly) .....   | 76        |
| 4.2.42. External Interrupt polarity select - LAS0 + 1A8h (WriteOnly) .....   | 76        |
| 4.2.43. User Timer/Counter 0 Clock Select - LAS0 + 1ACh (WriteOnly) .....  | 77        |
| 4.2.44. User Timer/Counter 0 Gate Select - LAS0 + 1B0h (WriteOnly) .....   | 77        |
| 4.2.45. User Timer/Counter 1 Clock Select - LAS0 + 1B4h (WriteOnly) .....  | 77        |
| 4.2.46. User Timer/Counter 1 Gate Select - LAS0 + 1B8h (WriteOnly) .....   | 77        |
| 4.2.47. User Timer/Counter 2 Clock Select - LAS0 + 1BCh (WriteOnly) .....  | 78        |
| 4.2.48. User Timer/Counter 2 Gate Select - LAS0 + 1C0h (WriteOnly) .....   | 78        |
| 4.2.49. User Output 0 Signal Select - LAS0 + 1C4h (WriteOnly) .....  | 78        |
| 4.2.50. User Output 1 Signal Select - LAS0 + 1C8h (WriteOnly) .....  | 79        |
| 4.2.51. McBSP A/D FIFO control - LAS0 + 1E8h (WriteOnly) .....   | 79        |
| 4.2.52. McBSP D/A1 and D/A2 FIFO control - LAS0 + 1ECh (WriteOnly) .....   | 79        |
| 4.3. LOCAL ADDRESS SPACE 1 (LAS1) .....  | 80        |
| 4.3.1. Local Address Space 1 +0h: Read A/D FIFO (Read only) .....  | 80        |
| 4.3.2. Local Address Space 1 +4h: Read High Speed Digital Input FIFO (Read only) .....   | 80        |
| 4.3.3. Local Address Space 1 +8h: Write D/A1 FIFO (Write only) .....   | 81        |
| 4.3.4. Local Address Space 1+Ch: Write D/A2 FIFO (Write only) .....  | 81        |
| <b>5. A/D CONVERSION .....</b>   | <b>82</b> |
| 5.1. BEFORE STARTING CONVERSIONS: INITIALIZING THE BOARD .....   | 82        |
| 5.1.1. Before Starting Conversions (single-channel mode): Programming Channel, Gain, Input Range and Type using Channel Gain Latch (CGL) ..... | 82        |
| 5.1.2. Before Starting Conversions (multi-channel mode): Programming the Channel-Gain Table (CGT) .....  | 82        |
| 5.1.3. 16-Bit A/D Table .....  | 82        |
| 5.1.4. Channel Select, Gain Select, Input Range and Input Type .....   | 84        |
| 5.1.5. Pause bit .....   | 84        |
| 5.1.6. D/Ax update bits .....  | 84        |
| 5.1.7. Skip bit .....  | 84        |
| 5.1.8. 8-Bit Digital Table .....   | 85        |
| 5.1.9. Setting Up A/D part and Digital part of Channel Gain Table .....  | 85        |
| 5.1.10. Using the Channel Gain Table for A/D Conversions .....   | 85        |
| 5.1.11. Channel-gain Table and Throughput Rates .....  | 87        |
| 5.2. A/D CONVERSION MODES .....  | 88        |
| 5.2.1. Start A/D Conversion signal .....   | 88        |
| 5.2.2. Pacer Clock Start/Stop Trigger Select .....   | 88        |
| 5.2.3. Types of Conversions .....  | 90        |
| 5.3. READING THE CONVERTED DATA .....  | 92        |
| 5.4. USING THE A/D DATA MARKERS .....  | 92        |
| 5.5. PROGRAMMING THE PACER CLOCK .....   | 93        |
| 5.6. PROGRAMMING THE BURST CLOCK .....   | 93        |
| 5.7. PROGRAMMING THE ABOUT COUNTER .....   | 94        |
| 5.7.1. Using the About Counter to Create Large Data Arrays .....   | 94        |

|  |            |
|--|------------|
| <b>6. D/A CONVERSION .....</b>   | <b>96</b>  |
| 6.1. 1024 SAMPLE BUFFER.....   | 99         |
| 6.2. D/A CYCLED OR NOT CYCLED MODE .....                                     | 100        |
| 6.3. D/A UPDATE COUNTERS .....   | 100        |
| 6.4. D/A DATA MARKERS .....  | 100        |
| <b>7. DATA TRANSFER USING DMA .....</b>                                      | <b>101</b> |
| 7.1 NON-CHAINING MODE DMA .....  | 101        |
| 7.2 CHAINING MODE DMA .....  | 101        |
| 7.3 DMA DATA TRANSFERS .....   | 102        |
| 7.3.1 Demand Mode DMA.....   | 102        |
| 7.3.2. DMA Priority.....   | 102        |
| 7.4 DMA REGISTERS .....  | 103        |
| 7.4.1. (DMAMODE0; PCI:80h) DMA Channel 0 Mode Register.....                  | 104        |
| 7.4.2. (DMAPADR0; PCI:84h) DMA Channel 0 PCI Address Register .....          | 105        |
| 7.4.3. (DMALADR0; PCI:88h) DMA Channel 0 Local Address Register.....         | 105        |
| 7.4.4. (DMASIZ0; PCI:8Ch) DMA Channel 0 Transfer Size (Bytes) Register ..... | 105        |
| 7.4.5. (DMADPR0; PCI:90h) DMA Channel 0 Descriptor Pointer Register.....     | 105        |
| 7.4.6. (DMAMODE1; PCI:94h) DMA Channel 1 Mode Register.....                  | 106        |
| 7.4.7. (DMAPADR1; PCI:98h) DMA Channel 1 PCI Address Register .....          | 107        |
| 7.4.8. (DMALADR1; PCI:9Ch) DMA Channel 1 Local Address Register .....        | 107        |
| 7.4.9. (DMASIZ1; PCI:A0h) DMA Channel 1 Transfer Size (Bytes) Register ..... | 107        |
| 7.4.10. (DMADPR1; PCI:A4h) DMA Channel 0 Descriptor Pointer Register .....   | 107        |
| 7.4.11. (DMACSR0; PCI:A8h) DMA Channel 0 Command/Status Register.....        | 108        |
| 7.4.12. (DMACSR1; PCI:A9h) DMA Channel 1 Command/Status Register.....        | 108        |
| 7.4.13. (DMAARB; PCI:ACh) DMA Arbitration Register.....                      | 109        |
| 7.4.14. (DMATHR; PCI:B0h) DMA Threshold Register.....                        | 109        |
| <b>8. INTERRUPTS .....</b>   | <b>110</b> |
| 8.1. THE OVERALL INTERRUPT STRUCTURE OF PCI4520/DM7520/DM7540.....           | 110        |
| 8.1.1. The Interrupt Sources of PCI4520/DM7520 .....                         | 110        |
| 8.1.2. The Interrupt Registers of PCI4520/DM7520 .....                       | 111        |
| 8.2. THE OPERATION OF ON-BOARD PRIORITY INTERRUPT CONTROLLER .....           | 112        |
| 8.3. ADVANCED DIGITAL INTERRUPTS .....                                       | 113        |
| 8.3.1. Event Mode.....   | 113        |
| 8.3.2. Match Mode.....   | 113        |
| 8.3.3. Sampling Digital Lines for Change of State .....                      | 113        |
| <b>9. TIMER/COUNTERS .....</b>   | <b>114</b> |
| 9.1. THE INTERNAL TIMER TIMER/COUNTERS .....                                 | 114        |
| 9.2. USER TIMER TIMER/COUNTERS .....   | 114        |
| <b>10. DIGITAL I/O .....</b>   | <b>116</b> |
| 10.1. THE DIGITAL I/O CHIP.....  | 117        |
| 10.1.1 Port 0, Bit Programmable Digital I/O.....                             | 117        |
| 10.1.2. Advanced Digital Interrupts: Mask and Compare Registers.....         | 117        |
| 10.1.3. Port 1, Port Programmable Digital I/O .....                          | 118        |
| 10.1.4. Resetting the Digital Circuitry.....                                 | 118        |
| 10.1.5. Strobing Data into Port 0.....                                       | 118        |
| 10.2. HIGH-SPEED DIGITAL INPUT .....   | 118        |
| 10.3. DIGITAL INPUT DATA MARKERS.....  | 118        |
| <b>11. CALIBRATION.....</b>  | <b>119</b> |
| 11.1. REQUIRED EQUIPMENT.....  | 119        |

|   |            |
|---|------------|
| 11.2. A/D CALIBRATION .....   | 119        |
| 11.2.1. Bipolar Calibration .....   | 119        |
| 11.2.3. Unipolar Calibration.....   | 121        |
| 11.2.4. Gain Adjustment.....  | 122        |
| 11.3. D/A CALIBRATION .....   | 123        |
| <b>12. SPECIFICATIONS .....</b>   | <b>125</b> |
| 12.1. COMPUTER INTERFACE.....   | 125        |
| 12.2. ANALOG INPUT CIRCUITRY .....  | 125        |
| 12.3. A/D CONVERTER.....  | 125        |
| 12.4. A/D SAMPLE BUFFER .....   | 125        |
| 12.5. CHANNEL GAIN TABLE .....  | 126        |
| 12.6. CLOCKS AND COUNTERS .....   | 126        |
| 12.7. DIGITAL I/O.....  | 126        |
| 12.8. D/A CONVERTER AND D/A CIRCUITRY .....   | 126        |
| 12.9. D/A SAMPLE BUFFER.....  | 126        |
| <b>APPENDIX A - THE PCI CONFIGURATION REGISTERS, LOCAL CONFIGURATION<br/>REGISTERS, RUNTIME REGISTERS, DMA REGISTERS, LOCAL ADDRESS SPACE 0 AND 1<br/>.....</b> | <b>127</b> |
| A1. PCI CONFIGURATION REGISTERS.....  | 134        |
| A.1.1. PCIIDR - Device ID, Vendor ID (PCI CFG offset:00, EEPROM offset:00).....   | 136        |
| A.1.2. PCICCR - Class Code (PCI CFG offset:09- 0B, EEPROM offset:04).....   | 136        |
| A.1.3. PCICLSR, PCI LTR, PCI HTR, PCIIPR PCIILR - (PCI CFG offset:0C.. 0E, 3D, 3C, EEPROM<br>offset:08).....  | 136        |
| A.1.4. PCISVID - PCI Subsystem Vendor ID (PCI CFG offset:2C, EEPROM offset:44) .....  | 136        |
| A.1.5. PEROMBA - Expansion ROM PCI Base Address Register(PCI CFG offset:30, EEPROM<br>offset:54).....   | 136        |
| A.2. LOCAL CONFIGURATION REGISTERS .....  | 137        |
| A.2.1. Range for PCI-to-Local Address Space 0 Register (LAS0RR, PCI:00h, EEPROM offset: 14).....  | 138        |
| A.2.2 Local Base Address (Remap) for PCI-to-Local Address Space 0 Register (LAS0BA, PCI: 04,<br>EEPROM offset: 18).....   | 138        |
| A.2.3 Mode/Arbitration Register (MARBR, PCI: 08, EEPROM offset: 1C).....  | 138        |
| A.2.4 Big/Little Endian Descriptor Register (BIGEND, PCI:0Ch, EEPROM offset: 20h) .....   | 139        |
| A.2.5 Expansion ROM Range Register (EROMRR, PCI:10h, EEPROM offset: 24h).....   | 140        |
| A.2.6 Expansion ROM Local Base Address (Remap) Register and BREQo Control (EROMBA, PCI:14h,<br>EEPROM offset: 28h) .....  | 140        |
| A.2.7 Local Address Space 0/Expansion ROM Bus Region Descriptor Register (LBRD0; PCI:18h,<br>EEPROM offset: 2Ch) .....  | 141        |
| A.2.8 Local Range Register for Direct Master to PCI (DMRR; PCI:1Ch, EEPROM offset: 30h)...  | 142        |
| A.2.9 Local Bus Base Address Register for Direct Master to PCI Memory (DMLBAM; PCI:20h,<br>EEPROM offset: 34h).....   | 142        |
| A.2.10 Local Base Address Register for Direct Master to PCI IO/CFG (DMLBAI; PCI:24h, EEPROM<br>offset: 38h).....  | 142        |
| A.2.11 PCI Base Address (Remap) Register for Direct Master to PCI Memory(DMPBAM; PCI:28h,<br>EEPROM offset: 3Ch) .....  | 143        |
| A.2.12 PCI Configuration Address Register for Direct Master to PCI IO/CFG (DMCFGA; PCI:2Ch,<br>EEPROM offset: 40h).....   | 144        |
| A.2.13 PCI Local Address Space 1 Range Register for PCI-to-Local Bus (LAS1RR; PCI:F0h, EEPROM<br>offset: 48h).....  | 144        |
| A.2.14 Local Address Space 1 Local Base Address (Remap) Register(LAS1BA; PCI:F4h, EEPROM<br>offset: 4Ch).....   | 145        |
| A.2.15 Local Address Space 1 Bus Region Descriptor Register (LBRD1; PCI:F8h, EEPROM offset: 50h)<br>.....   | 145        |
| A.3. RUNTIME REGISTERS .....  | 146        |

*A.3.1 Serial EEPROM Control, PCI Command Codes, User I/O Control, Init Control ((CNTRL;  
PCI:6Ch, no EEPROM loadable) ..... 147*

A.4. DMA REGISTERS..... 147

A.5. LAS0 REGISTER AREA ..... 147

A.6. LAS1 REGISTER AREA ..... 147

**APPENDIX B - THE PLX9080 EEPROM CONTENT ..... 148**

**APPENDIX C - DIFFERENCIES BETWEEN THE PCI4520 AND THE DM7520, DM7540  
BOARDS ..... 149**

**LIMITED WARRANTY..... 150**

## 1. Overview

The PCI4520/DM7520/DM7540 boards turn your PC/104 stack into a high-speed, high-performance data acquisition and control system. The PCI4520/DM7520/DM7540 busmaster DAQ boards are basically equivalent systems. There are some differences which are discussed in the appropriate place of the manual. There is a list about the differences in Appendix C.

Boards features:

- 8 differential, 16 single-ended analog input channels,
- 12-bit, 1.25 Msample/s analog-to-digital converter ,
- Programmable input ranges: +-5, +-10, or 0 to +10 volts,
- Programmable gains of 1, 2, 4, 8, 16, 32, PCI4520 has 64 & 128 gain factors also,
- 1024 x 24 channel-gain scan memory with skip bit,
- Software, pacer clock and external trigger modes,
- Scan, burst and multiburst using the channel-gain table,
- 10-bit programmable high speed sample counter and 16-bit delay counter,
- 1024 sample A/D buffer for gap-free full-speed sampling under Windows™ and DOS
- Pre-, post- and about-trigger modes,
- 8-bit High-Speed Digital Input with 1KSample FIFO,
- 8 bit programmable digital I/O lines with Advanced Digital Interrupt modes,
- 8 bit port programmable digital I/O lines,
- 24.. 10-bit timer/counters (three software configurable available to user in well known 8254 chip) and on-board 8 MHz clock,
- Two 12-bit, 10 microsecond digital-to-analog output channels with 100 kHz throughput,
- +-5V, 0 to +5, +-10V, or 0 to +10 Volt analog output range,
- Two 1024 sample D/A buffers for gap-free full-speed output under Windows™ and DOS
- 2-bit analog output data trigger/marker,
- three-line SyncBus for synchronized multiboard operation
- Built-in interrupt priority controller for several simultaneous interrupt source handling,
- PCI Busmaster Interface with max. 20MSample/s Burst mode data transfer with built-in two-channel DMA controller

The following paragraphs briefly describe the major functions of the PCI4520/DM7520/DM7540. A detailed discussion of board functions is included in subsequent chapters. The Figure 1.1 shows the simplified block diagram of the board.

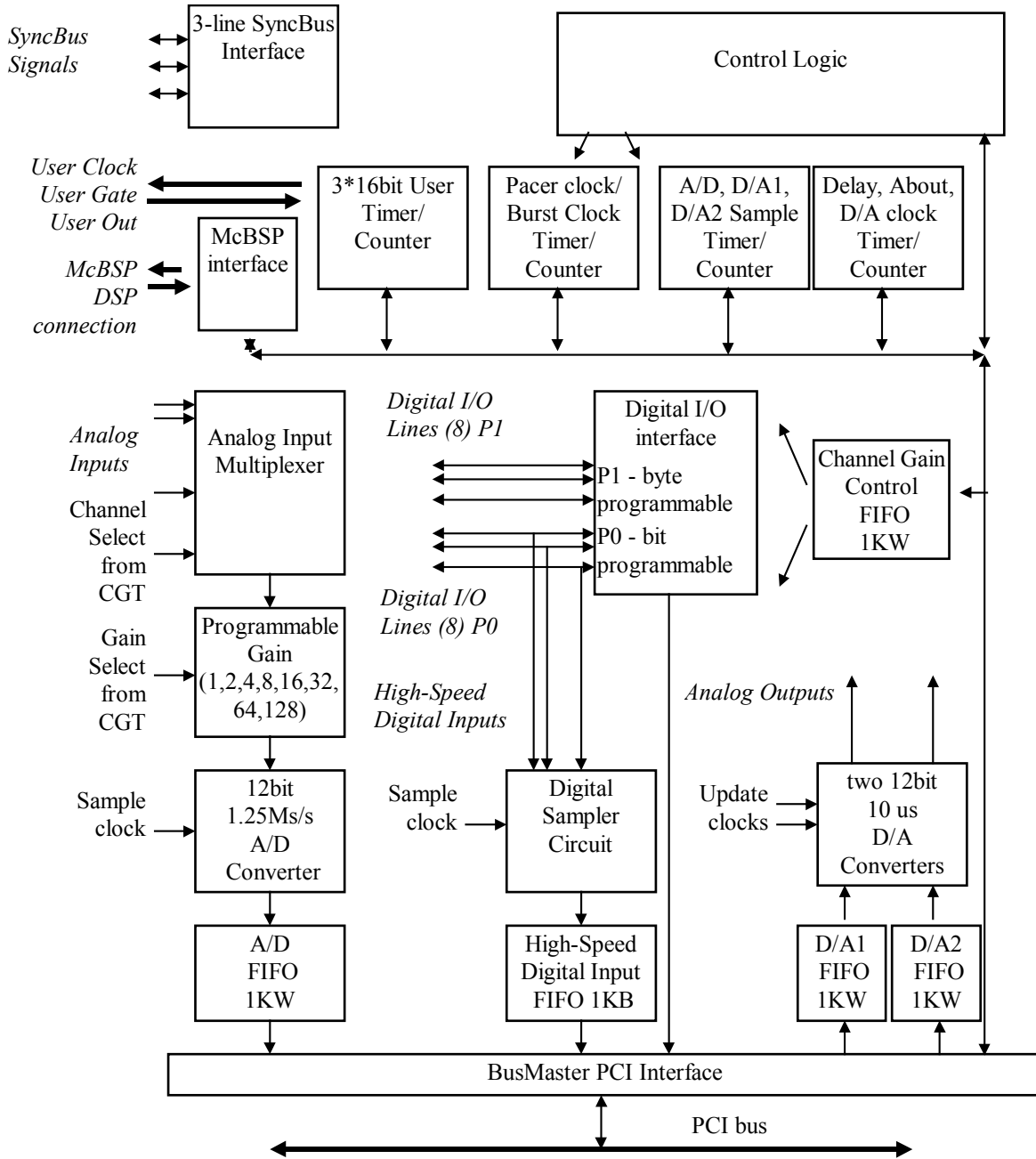

Figure 1.1.

### 1.1. Analog-to-Digital Conversion

The PCI4520/DM7520/DM7540 is software configurable on a channel-by-channel basis for up to 16 single-ended (Ground referenced or Non ground referenced) or 8 differential analog inputs. Software programmable unipolar and bipolar input ranges and gains allow easy interfacing to a wide range of sensors. Overvoltage protection to +12 volts is provided at the inputs. The common mode input voltage for differential operation is +10 volts.

A/D conversions are typically performed in 0.8 microseconds, and the maximum throughput rate of the board is 1.25 MHz. In the case of multi-channel operation the Channel Gain Table FIFO controls the

analog multiplexers, the gain, and The A/D conversion. Conversions can be controlled by software command, by an on-board pacer clock, by using triggers to start and stop sampling, or by using the sample counter to acquire a specified number of samples. Several trigger sources can be used to turn the pacer clock on and off, giving you exceptional flexibility in data acquisition. Scan, burst, and multiburst modes are supported by using the channel-gain scan memory. A first in, first out (FIFO) sample buffer helps your computer manage the high throughput rate of the A/D converter by acting as an elastic storage bin for the converted data. Even if the computer does not read the data as fast as conversions are performed, conversions can continue until the FIFO is full.

The converted data can be transferred using the programmed I/O mode or the interrupt mode, or using the on-board two-channel DMA controller. A special interrupt mode using a REP INS (Repeat Input String) instruction supports very high speed data transfers by generating an interrupt when the FIFO's half-full flag is set, or a specified number of data are converted, a REP INS instruction can be executed, transferring data to PC memory and emptying the FIFO buffer at the maximum rate allowed by the data bus. The data transfer can be done in burst mode of the PCI bus. The on-board DMA controller assures the highest efficiency data transfer between the board and the memory of the PC in burst mode without CPU intervention.

## **1.2. Digital-to-Analog Conversion**

The digital-to-analog (D/A) circuitry features two independent 12-bit analog output channels with individually programmable output ranges of -5 to +5 volts, 0 to +5 volts, -10 to +10 volts or 0 to +10 volts. Each channel has its own 1024 sample FIFO buffer for data storage before being output. Data can be continuously written to the buffer producing a non-repetitive output waveform or a set of data can be written into the buffer and continuously cycled to produce a repeating waveform. Data can be written into the output buffers by memory write instruction. Updating of the analog outputs can be done through software or by several different clocks and triggers. The outputs can be updated simultaneously or independently.

## **1.3. Timer/Counters**

Eight programmable internal timers 10.. 16-bit to support a wide range of board operations and an 8254 User TC for user timing and counting functions. One internal timer are used for the pacer clock (24bit), one is used for the burst clock (10bit), one is used for the A/D sample counter (10bit), one is used for the D/A1 sample counter (10bit), one is used for the D/A2 sample counter (10bit), one is used for the A/D delay counter (16bit), one is used for the A/D about counter (16bit), one is used for D/A output clock (16bit).. The three channel timer/counters of 8254 are available for user functions.

## **1.4. Digital I/O**

The PCI4520/DM7520/DM7540 has 16 buffered TTL/CMOS digital I/O lines with eight independent, bit programmable lines at Port 0, and an 8-bit programmable port Port 1. The bit programmable lines support RTD's two Advanced Digital Interrupt modes. An interrupt can be generated when any bit changes value (event interrupt), or when the lines match a programmed value (match interrupt). For either mode, masking can be used to monitor selected lines. Lines are pulled up by 10kOhm resistors. Port 0 and Port 1 are accessed through the rear CN2 Back-Plate 68 pin I/O connector.

## **1.5. High-Speed Digital Input**

The PCI4520/DM7520/DM7540 has 8bit buffered TTL/CMOS High speed digital Input lines with 1KSample FIFO buffer. These lines are shared with the Digital I/O P0 port. Lines are pulled up by 10kOhm resistors and can be accessed through the rear CN2 Back-Plate 68 pin I/O connector.

The sampling signal can be programmed, the FIFO status can be monitored, or the number of sampled data can be counted by User TC1.

## **1.6. SyncBus**

The three-line SyncBus assures the possibility of using multiply PCI4520/DM7520/DM7540 in one computer synchronously.

## **1.7. McBSP Multi-channel Buffered Serial Port (DM7540 only)**

The ten-line (including GNDs) McBSP assures the possibility of using a dspModule with DM7540 together. This means, that the connected DSP (f. e. RTD SPM 6020/6030) has a direct connection to the analog world using the DM7540 as a front-end board.

## **1.8. What Comes With Your Board**

You receive the following items in your board package:

- PCI4520/DM7520/DM7540 DAQ board
- Software Support (See Software Manual)
- Manual(s)

If any item is missing or damaged, please call Real Time Devices' Customer Service Department at (814) 234-8087. If you require service outside the US, contact your local distributor.

## **1.9. Board Accessories**

In addition to the items included in your PCI4520/DM7520/DM7540 package, Real Time Devices offers a full line of software and hardware accessories. Call your local distributor or our main office for more information about these accessories and for help in choosing the best items to support your board's application.

## **1.10. Hardware Accessories**

Hardware accessories for the PCI4520/DM7520/DM7540 include the TMX32 analog input expansion board with thermocouple compensation which can expand a single input channel on your PCI4520/DM7520/DM7540 to 16 differential or 32 single-ended input channels, the OP series opto-isolated digital input boards, the MR series mechanical relay output boards, the OR16 opto-isolated digital input/mechanical relay output board, the USF8 universal sensor interface with sensor excitation, the TS16 thermocouple sensor board, the TB68 terminal board and XB68 prototype/terminal board for easy signal access and prototype development, and XD68 wire flat ribbon cable assembly for external interfacing.

## **1.11. Using This Manual**

This manual is intended to help you install your new board and get it running quickly, while also providing enough detail about the board and its functions so that you can enjoy maximum use of its features even in the most complex applications. We assume that you already have an understanding of data acquisition principles and that you can customize the example software or write your own application programs.

## **1.12. When You Need Help**

This manual and the example programs in the software package included with your board provide enough information to properly use all of the board's features. If you have any problems installing or using this board, contact our Technical Support Department, (814) 234-8087, during regular business hours, eastern standard time or eastern daylight time, or send a FAX requesting assistance to (814) 234-5218. When sending a FAX request, please include your company's name and address, your name, your telephone number, and a brief description of the problem. You can also contact us through our E-mail address [techsupport@rtdusa.com](mailto:techsupport@rtdusa.com).

## 2. Installation

The PCI4520/DM7520/DM7540 is easy to install in your PC computer with PCI bus. This chapter tells you step-by-step how to install and connect the board.

After you have installed the board and made all of your connections, you can turn your system on and run the board diagnostics program included on your example software disk to verify that your board is working.

### 2.1. Board Installation

Keep the board in its antistatic bag until you are ready to install it in your computer. When removing it from the bag, hold the board at the edges and do not touch the components or connectors.

This section describes the PCI4520 installation.

Before installing the board in your computer, check the switch settings (SW1 and SW2) of analog input lines. There are no other switch or jumper on the board. Chapter 3 explains the role of switches (SW1), (SW2) and reviews the factory settings and how and why to change them.

To install the PCI4520 board:

1. Turn OFF the power to your PC.
  2. Remove the top cover of the computer housing (refer to your owner's manual if you do not already know how to do this).
  3. Select any unused PCI BusMaster expansion slot (rev. 2.0 or greater) and remove the slot bracket.
  4. Touch the metal housing of the computer to discharge any static buildup and then remove the board from its antistatic bag.
  5. Holding the board by its edges, orient it so that its card edge (bus) connectors line up with the expansion slot connectors in the bottom of the selected expansion slot.
  6. After carefully positioning the board in the expansion slot so that the card edge connectors are resting on the computer's bus connectors, gently and evenly press down on the board until it is secured in the slot.
- NOTE: Do not force the board into the slot. If the board does not slide into place, remove it and try again. Wiggling the board or exerting too much pressure can result in damage to the board or to the computer.
7. After the board is installed, secure the slot bracket back into place and put the cover back on your computer. The board is now ready to be connected via the external I/O connector at the rear panel of your computer. Be sure to observe the keying when connecting your external cable to the I/O connector.

To install the DM7520/DM7540 board:

1. Turn OFF the power to your PC/104plus stack power.
2. Remove the cover of the stack.
3. Touch the metal housing of the PC/104plus stack to discharge any static buildup and then remove the board from its antistatic bag.
4. Finding slot position and setting rotary switch and JP1 BusMaster/Target only mode jumper.
  - a.) JP1 installed – BusMaster mode. Select any unused PCI BusMaster board position and set the rotary switch (RSW1) on the DM7520 to the position number. The closest position to the cpuModule is the 0 the next is the 1 etc. Be careful, this DAQ board needs a busmaster position. If you use CMM7686GX RTD cpuModule you may have two BusMaster board in position 0 and 1.
  - b.) JP1 not installed – Target Only mode. If you are short of BusMaster positions or you have any other reason, why you want to use the DM7520 as target only mode follow these instructions. Select any unused PCI target only board position and set the rotary switch (RSW1) on the DM7520 to the proper position number. The closest position to the cpuModule is the 0 the next is the 1 etc.. If you use CMM7686GX RTD cpuModule you may have two BusMaster board in position 0 and 1 and you may have target only boards position 2 and 3.
5. Install the board into your PC/104 system. Use Metal holders to the keep the appropriate distances between the boards.

6. The board is now ready to be connected via the external I/O connector. Be sure to observe the keying when connecting your external cable to the I/O connector.

## 2.2. External I/O Connections

Figure 2.1. shows the PCI4520 Con2 68-pin male I/O connector at the backplate, and the Table 2.1. shows the pinouts while Table 2.2. gives the description of signals. Refer to these diagrams as you make your I/O connections.

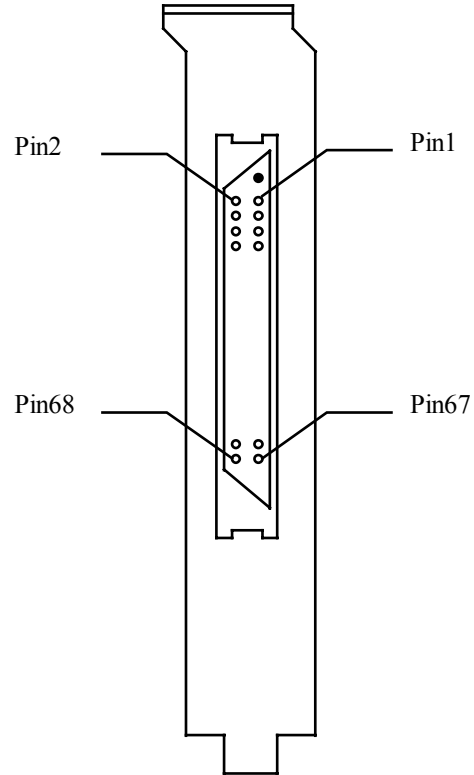

Figure 2.2.1

The type of the 68 pin male connector is:

AMP 2-174-341-5

or

HONDA PCS-E68LMD

Figure 2.1. shows the DM7520/DM7540 CN2 68-pin male I/O connector at the left side of the PC/104plus board, and the Table 2.1. shows the pinouts while Table 2.2. gives the description of signals. Refer to these diagrams as you make your I/O connections.

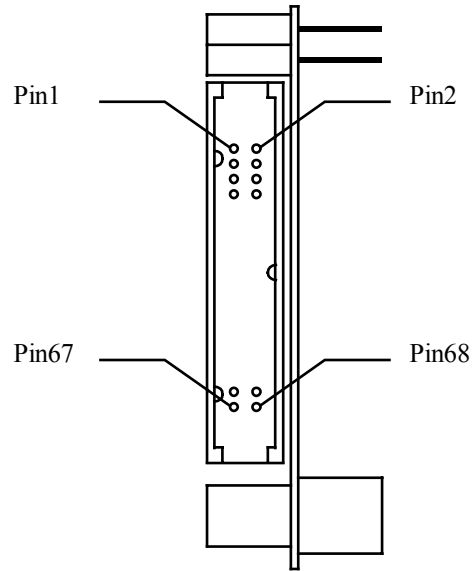

Figure 2.2.2

|                     |    |    |                            |
|---------------------|----|----|----------------------------|
| AIN 9 / AIN1-       | 2  | 1  | AIN 1 / AIN1+              |
| AIN 10 / AIN2-      | 4  | 3  | AIN 2 / AIN2+              |
| AIN 11 / AIN3-      | 6  | 5  | AIN 3 / AIN3+              |
| AIN 12 / AIN4-      | 8  | 7  | AIN 4 / AIN4+              |
| AGND                | 10 | 9  | AINSENSE                   |
| AIN 13 / AIN5-      | 12 | 11 | AIN 5 / AIN5+              |
| AIN 14 / AIN6-      | 14 | 13 | AIN 6 / AIN6+              |
| AIN 15 / AIN7-      | 16 | 15 | AIN 7 / AIN7+              |
| AIN 16 / AIN8-      | 18 | 17 | AIN 8 / AIN8+              |
| AGND                | 20 | 19 | AGND                       |
| Reserved            | 22 | 21 | AOUT 1                     |
| Reserved            | 24 | 23 | AOUT 2                     |
| AGND                | 26 | 35 | Reserved                   |
| AGND                | 28 | 27 | AGND                       |
| D/A 2 DATA MARKER 0 | 30 | 29 | D/A 1 DATA MARKER 0        |
| P1.7 / DIG TABLE 7  | 32 | 31 | HIGH SPEED INPUT 7 / P0.7  |
| P1.6 / DIG TABLE 6  | 34 | 33 | HIGH SPEED INPUT 6 / P0.6  |
| P1.5 / DIG TABLE 5  | 36 | 35 | HIGH SPEED INPUT 5 / P0.5  |
| P1.4 / DIG TABLE 4  | 38 | 37 | HIGH SPEED INPUT 4 / P0.4  |
| P1.3 / DIG TABLE 3  | 40 | 39 | HIGH SPEED INPUT 3 / P0.3  |
| P1.2 / DIG TABLE 2  | 42 | 41 | HIGH SPEED INPUT 2 / P0.2  |
| P1.1 / DIG TABLE 1  | 44 | 43 | HIGH SPEED INPUT 1 / P0.1  |
| P1.0 / DIG TABLE 0  | 46 | 45 | HIGH SPEED INPUT 0 / P0.0  |
| DGND                | 48 | 47 | TRIGGER INPUT              |
| RESET               | 50 | 49 | EXTERNAL PACER CLOCK INPUT |
| DGND                | 52 | 51 | EXTERNAL INTERRUPT INPUT   |
| USER INPUT 1        | 54 | 53 | USER INPUT 0               |
| USER OUTPUT 1       | 56 | 55 | USER OUTPUT 0              |
| DGND                | 58 | 57 | TC OUT 0                   |
| EXTERNAL TC GATE 1  | 60 | 59 | EXTERNAL TC CLOCK 1        |
| TC OUT 2            | 62 | 61 | TC OUT 1                   |
| EXTERNAL TC GATE 2  | 64 | 63 | EXTERNAL TC CLOCK 2        |
| DGND                | 66 | 65 | +5 VOLTS                   |
| DGND                | 68 | 67 | +5 VOLTS                   |

Table 2.2.1

|  |                        |   |
|--|------------------------|---|
| AIN <sub>x</sub> / AIN <sub>x+</sub> / AIN <sub>x-</sub> | Signal Type            | SE Analog input high sides / DIFF analog input high sides / DIFF analog inputs low sides.                                     |
| AGND   | Analog                 | Analog ground.  |
| AINSENSE   | Analog Input           | Reference Signal in Non ground referenced Single Ended (NRSE) input mode.   |
| AOUT x   | Analog Output          | Analog outputs.   |
| Reserved   | -                      | Not connected pins.   |
| D/A x DATA MARKER 0                                      | Digital Output         | D/A 1 and D/A 2 0 th.output data markers.   |
| HIGH SPEED INPUT x / P0.x / Digital Input Data Markers   | Digital Input / Output | High speed inputs to digital input FIFO / Bit programmable P0 lines from digital I/O Chip.                                    |
| P1.x / DIG TABLE x                                       | Digital Input / Output | Port programmable lines from digital I/O Chip. Outputs from digital part of channel gain table.                               |
| DGND   | Digital                | Digital ground.   |
| TRIGGER INPUT  | Digital Input          | External trigger input to trigger A/D pacer clock. (LS TTL)   |
| EXTERNAL PACER CLOCK INPUT                               | Digital Input          | External pacer clock to clock A/D. (LS TTL)   |
| EXTERNAL INTERRUPT INPUT                                 | Digital Input          | Programmable rising or falling edge external Interrupt source. (LS TTL)   |
| USER INPUT x   | Digital Input          | User Input 0 and User Input 1 can be read by the LAS0+04h I/O read instruction. . (LS TTL)                                    |
| USER OUTPUT x  | Digital Output         | The source of these buffered lines can be programmed. (LS TTL)  |
| TC OUT x   | Digital Output         | Buffered outputs from the user timer/counters. (LS TTL)   |
| EXTERNAL TC CLOCK x                                      | Digital Input          | External clock signals that go to the software programmable clock source select circuit for the user timer/counters. (LS TTL) |
| EXT GATE x   | Digital Input          | External gate signals that go to the software programmable clock source select circuit for the user timer/counters. (LS TTL)  |
| RESET  | Digital Output         | Active low reset output line asserted when the host PC is in hardware reset, or the Board Clear Command is active. (LS TTL)   |
| +5 VOLTS   | Power                  | +5 Volts from the computer power supply to power front end boards. (Max. 2A)  |

Table 2.2.2. - The I/O Connector Signal Description

### **2.3. Connecting the Analog Input Pins**

The PCI4520/DM7520/DM7540 provides flexible input connection capabilities to accommodate a wide range of sensors. You can mix several *input* modes:

- Ground Referenced Single-Ended (GRSE),
- Non Referenced Single-Ended (NRSE),
- Differential (DIFF) without ground reference, Differential with a dedicated ground, Differential with a separate ground reference through a 10 kOhm resistor.

All of three modes are software selectable. Inside the differential mode the no grounding, the grounding directly or via a 10kOhm resistor of low side of source can be done by setting the DIP switches on SW1 and SW2. The position of the SW1 and SW2 Switches can be seen in the Figure 2.3.1.

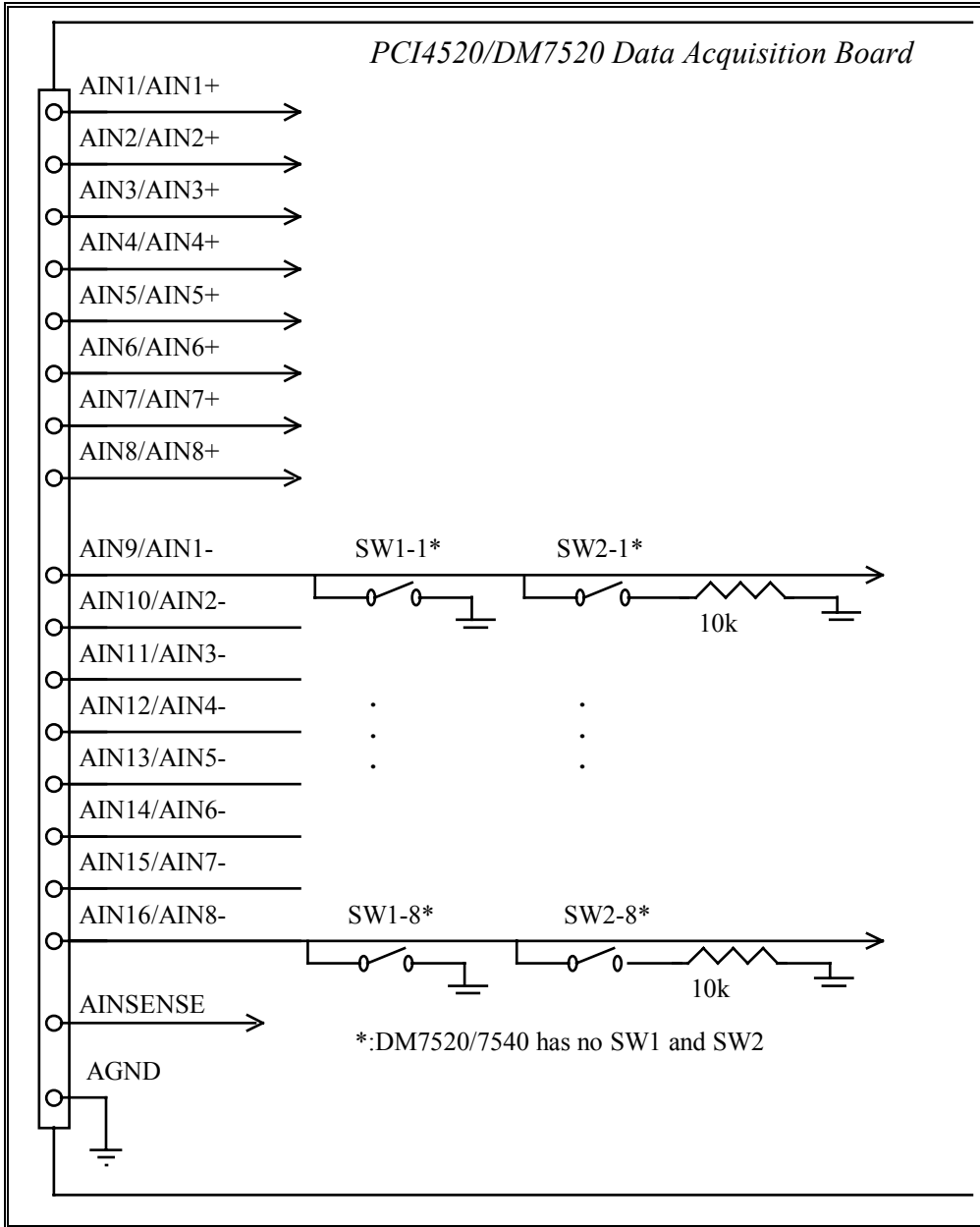

Figure 2.3.1.

The Differential with a dedicated ground mode is actually a single ended mode, but the channel number is only 8 channel and each channel have a dedicated ground pin and ground wire in the cable between the board and the signal conditioning card. This mode can be useful when the shielding of the signal is important.

In the followings the analog input modes are explained by text and Figures. In the Figures You can see the simplified block diagram of the analog input section of the Board. The NRSEH, ADCDIFFH INSTGNDH, AINSENSEH are the inside logic state variables for controlling the analog input operation. The switches are realized by analog multiplexers.

**2.3.1. Ground Referenced Single-Ended (GRSE) input mode**

*This mode is suggested only for floating signal sources to avoid the ground loops. To configure the GRSE analog input, connect the high side of the input signal to the selected analog input channel, AIN1*

through AIN16, and connect the low side to any of the ANALOG GND pins available at the connector. If you use the channels 9.. 16 switch the appropriate SW1-x and SW2-x off. (See Figure 2.3.1.)

In the Figure 2.3.2 you can see the switch states of this mode. The NRSEH bit is in low state which means that this is not NRSE mode. ADCDIFFH bit is in low state because this is not a differential mode. The INSTGNDH bit is in high state controlling the connection of low side of Instrumentation Amplifier to Analog Ground (AGND). The AINSENSEH bit is in low state because the reference signal of Instrumentation Amplifier is the Analog Ground.

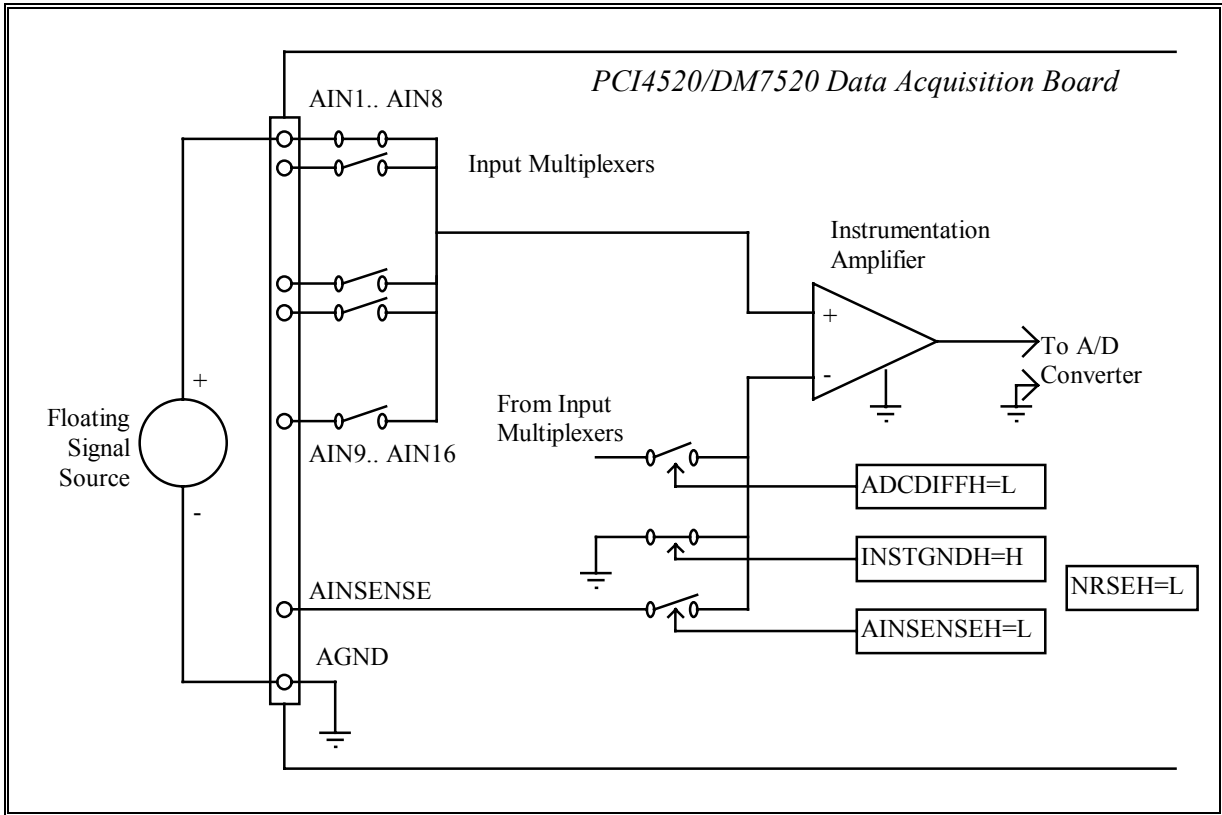

Figure. 2.3.2. Ground Referenced Single Ended input mode

### 2.3.2. Non Referenced Single-Ended (NRSE) input mode

This mode can be used - first of all - for grounded signal sources (in the Figure 2.3.3.), but can be used for floating sources too. In the case of floating sources an external resistor is needed to ground the AINSENSE signal. To configure the NRSE analog input, connect the high side of the input signal to the selected analog input channel, AIN1 through AIN16, and connect the low side to the AINSENSE pin available at the connector. If you use the channels 9.. 16 switch the appropriate SW1-x and SW2-x off. (See Figure 2.3.1.)

In the Figure 2.3.3 You can see the switch states of this mode. The NRSEH bit is in high state which means that this is the NRSE mode. ADCDIFFH bit is in low state because this is not a differential mode. The AINSENSEH bit is in high state controlling the connection of low side of Instrumentation Amplifier to AINSENSE signal. The INSTGNDH bit is in low state because the reference signal of Instrumentation Amplifier is the AINSENSE signal.

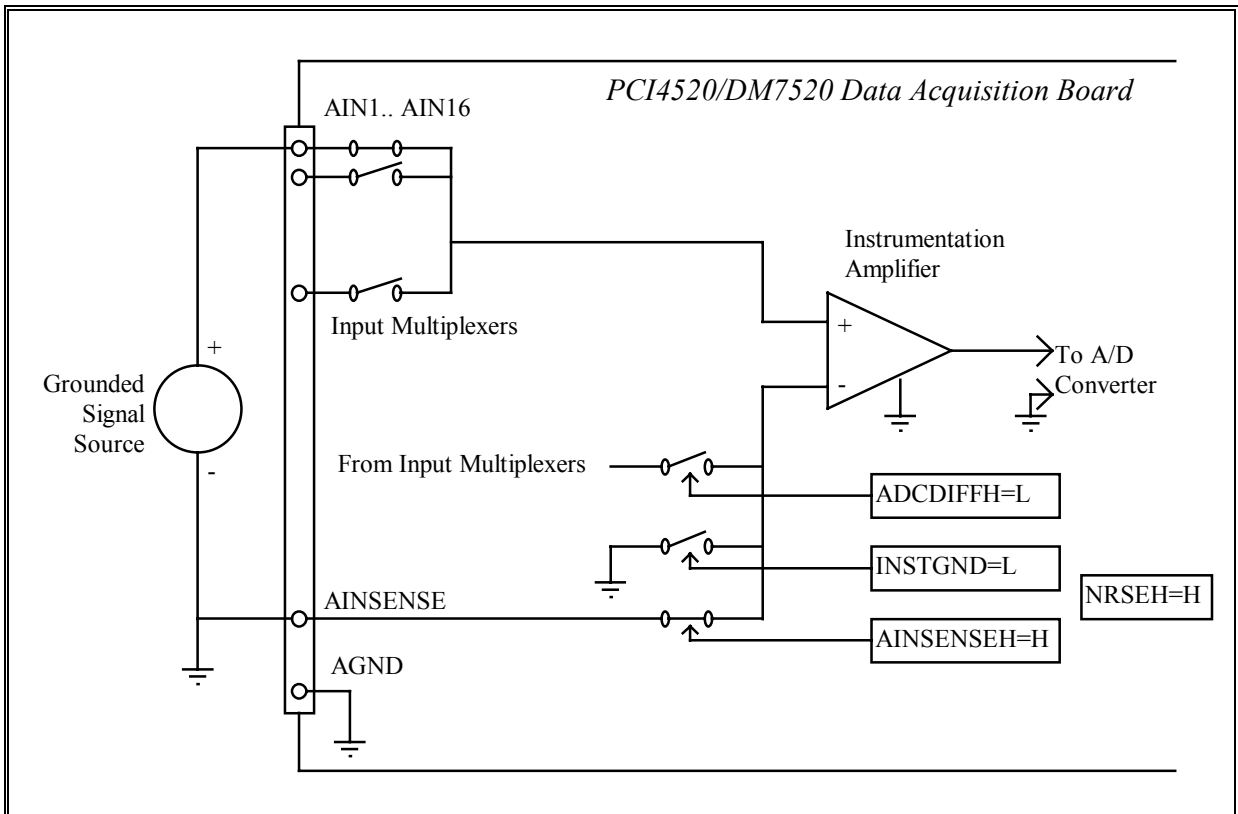

Figure. 2.3.3 Non Referenced Single-Ended input mode

### 2.3.3. Differential (DIFF) input mode

For differential inputs, your signal source may or may not have a separate ground reference. When using the differential mode, you may need to close the selected channel's DIP switch on SW2 to provide a reference to ground for a signal source without a separate ground reference. (In the Figure 2.3.4.) When you close a DIP switch on SW2, make sure that the corresponding DIP switch on SW1 is open, or the resistor will be bypassed. If you want to use direct grounding the appropriate SW1 switch can be switched on. On DM7520 there are no switches, therefore you must use external components.

Connect the high side of the analog input to the selected analog input channel, AIN1+ through AIN8+, and connect the low side to the corresponding AIN- pin.

In the Figure 2.3.4 You can see the switch states of this mode. The state of NRSEH bit is indifferent in the DIFF mode. The ADCDIFFH bit is in high state controlling the connection of low side of Instrumentation Amplifier to AIN- signal. The INSTGNDH bit is in low state because the reference signal of Instrumentation Amplifier is the AIN- signal. The AINSENSEH bit is in low state because the reference signal of Instrumentation Amplifier is the AIN- signal in DIFF mode.

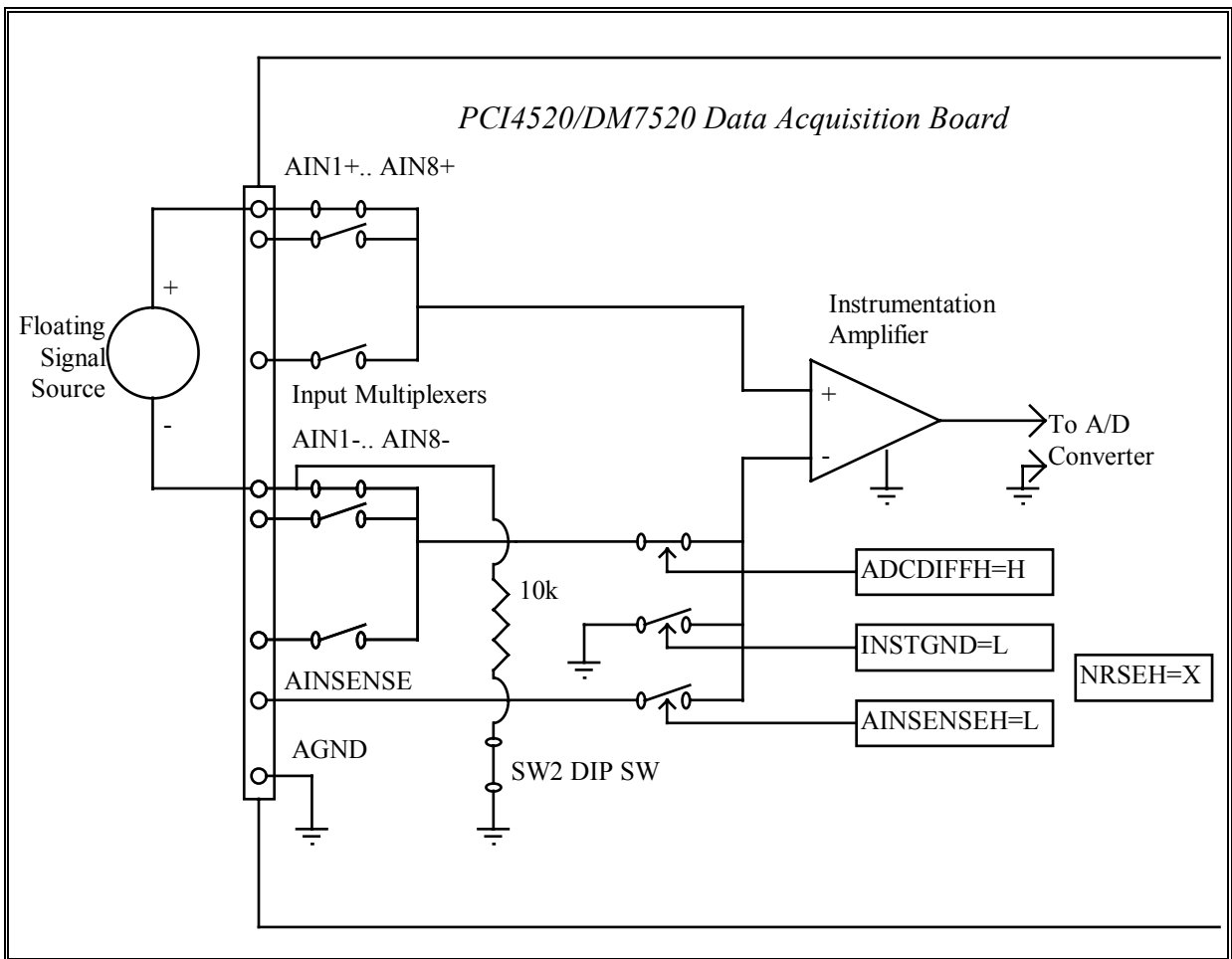

Figure 2.3.4. Differential input mode

### 2.4. Connecting the Analog Outputs

For each of the two D/A outputs, connect the high side of the device receiving the output to the AOUT channel and connect the low side of the device to an ANALOG GND.

### 2.5. Connecting the Timer/Counters and Digital I/O

For all of these connections, the high side of an external signal source or destination device is connected to the appropriate signal pin on the I/O connector, and the low side is connected to any DIGITAL GND.

The termination circuit of digital input/output can be seen in the Figure 2.5.1. In the case of digital input lines the serial 100ohm resistor is missing, and in the case of digital output lines the 10kOhm pullup resistor is missing.

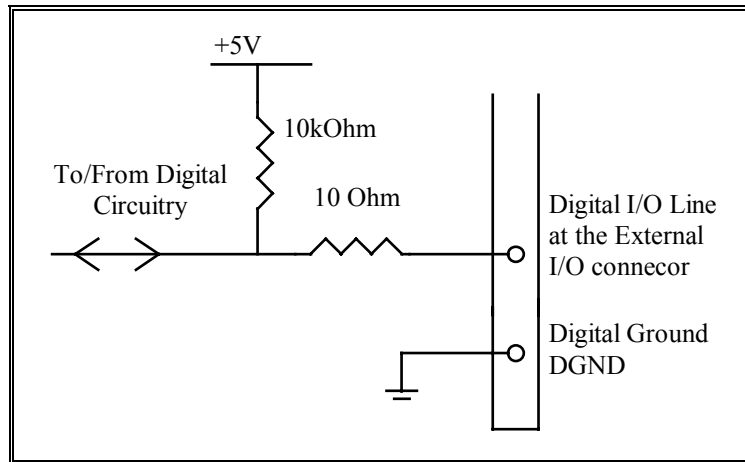

Figure 2.5.1.

### 2.6. Connecting the SyncBus

The SyncBus is an RTD defined digital bus for synchronous operation with other RTD's boards. The signaling level is TTL, the bus is 5V compliant. The SyncBus connector is the (10 pin right-angle 100mil header) P3 Connector at the right top corner of the board. The SyncBus is TTL signaling level and 5V compliant. See Table 4.2.1.f. There are no pull-up resistors on the bus-type lines. If a line is used, there need to be exist a master/driver of this line somewhere in the system.

|          |   |    |     |
|----------|---|----|-----|
| SyncBus0 | 1 | 2  | GND |
| GND      | 3 | 4  | GND |
| SyncBus1 | 5 | 6  | GND |
| GND      | 7 | 8  | GND |
| SyncBus1 | 9 | 10 | GND |

Table 2.6.1

## 2.7. Connecting the McBSP

The McBSP Multichannel Buffered Serial a Texas Instruments defined serial bus for DSP and front-end communication. This port is 5Vcompliant.

The McBSP connector is a 10 pin right-angle 100mil header – P4 Connector at the right mid corner of the board. These lines must be connected directly to the appropriate DSP signals. This connection needs a straight 10-pin cable.

|      |   |    |     |
|------|---|----|-----|
| CLKS | 1 | 2  | GND |
| CLKR | 3 | 4  | FSR |
| CLKX | 5 | 6  | GND |
| DR   | 7 | 8  | FSX |
| DX   | 9 | 10 | GND |

Table 2.6.1

### 3. Hardware Description

This chapter describes the features of the PCI4520/DM7520/DM7540 hardware. The major circuits are the A/D, the D/A, the timer/counters, and the digital I/O lines. This chapter describes the hardware which makes up the major circuits.

#### 3.1. The Operation of Analog Input and High-Speed Digital Input Section

##### 3.1.1. Overall Description

The Figure 3.1.1. shows the structure of Analog and High-Speed Digital Input Section of the Board. The Board has 16 Se. (ground referenced or non ground referenced) or 8 Diff. inputs which are multiplexed. The input voltage range is software programmable for -5 to +5 volts, -10 to +10 volts, or 0 to +10 volts. Overvoltage protection to  $\pm 12$  volts is provided at the inputs. The multiplexed signal can be amplified with programmable gain. Software programmable binary gains of 1, 2, 4, 8, 16, 32, 64, and 128 let you amplify lower level signals to more closely match the board's input ranges. The multiplexed and gained analog signal is converted by the A/D converter. The converted data is written to the 1KW FIFO. The High-Speed Digital Input lines can be simultaneously sampled with the analog lines. This mode is the Input Data Marker Mode which can be used to sample digital data synchronized with analog signals. The Sampling Signal of the High-Speed Digital Input can be selected to other sources too. The sampled digital data are written to the High-Speed Digital Input FIFO. The channel type, the channel gain and other control bits may come from the channel gain latch or from the channel gain table. The Channel Gain Latch can be used in single-channel operation mode, and the Channel Gain Table can be used in multi-channel operation mode.

##### 3.1.2 Channel Gain Latch (CGL) and Channel Gain Table (CGT)

In the case of single-channel operation the Channel Gain Latch mode must be set by appropriate software instruction. Then the Channel Gain Latch must be loaded. This mode assures the highest sampling rate at the highest accuracy. This mode can be used for *analog trigger* function. You can use one of the input channels as *Analog Trigger Input*. Set the Channel input type, the number and gain according to the signal source from software. Reading the converted data from the input channel the analog trigger event can be detected. When the trigger event has been detected, the multichannel -Channel Gain Table mode can be started.

The Channel-Gain Table lets you sample channels in any order, at high speeds, with a different gain on each channel. This 1024 x 24-bit memory supports complex channel-gain scan sequences, including digital output control. Using the digital output control feature, you can control external input expansion boards such as the TMX32 to expand channel capacity to up to 512 channels. When used, these control lines are output on Port 1. When the digital lines are not used for this feature, they are available for other digital control functions.

A skip bit is provided in the channel-gain data word to support different sampling rates on different channels. When this bit is set, an A/D conversion is performed on the selected channel but not stored in the FIFO.

In the case of multichannel operation the Channel Gain Table must be enabled by appropriate software instruction. Then the Channel Gain Table must be cleared and filled with the appropriate entries by the appropriate software instruction. After this setup the read pointer of the Channel Gain Table points to the first entry. The first A/D conversion works according to the first entry of CGT. After an active Conversion Signal (See 2.3 The A/D Conversion Signal) the A/D Converter asserts the End of Conversion Signal. This signal increases the read pointer of the Channel Gain Table and writes the converted data to the

A/D FIFO and the sampled High-Speed Digital Input lines to the FIFO if the High Speed Digital Input is in Data Marker Mode. The next conversion works according to the second entry of CGT etc. After reading the last entry, the read pointer automatically returns to the first entry of the CGT. This returning can be activated by Reset Channel Gain Table software instruction.

The Channel Gain Table assures the possibility of independent programming of the channel type (GRSE., NRSE or DIFF.), the channel gain (1..128) and the input range (+-5V, +-10V or 0..10V). Therefore CGT assures the possibility of simultaneous update the D/A1 and D/A2 with the appropriate input channels. These functions can be reached via the bits CGT entries.

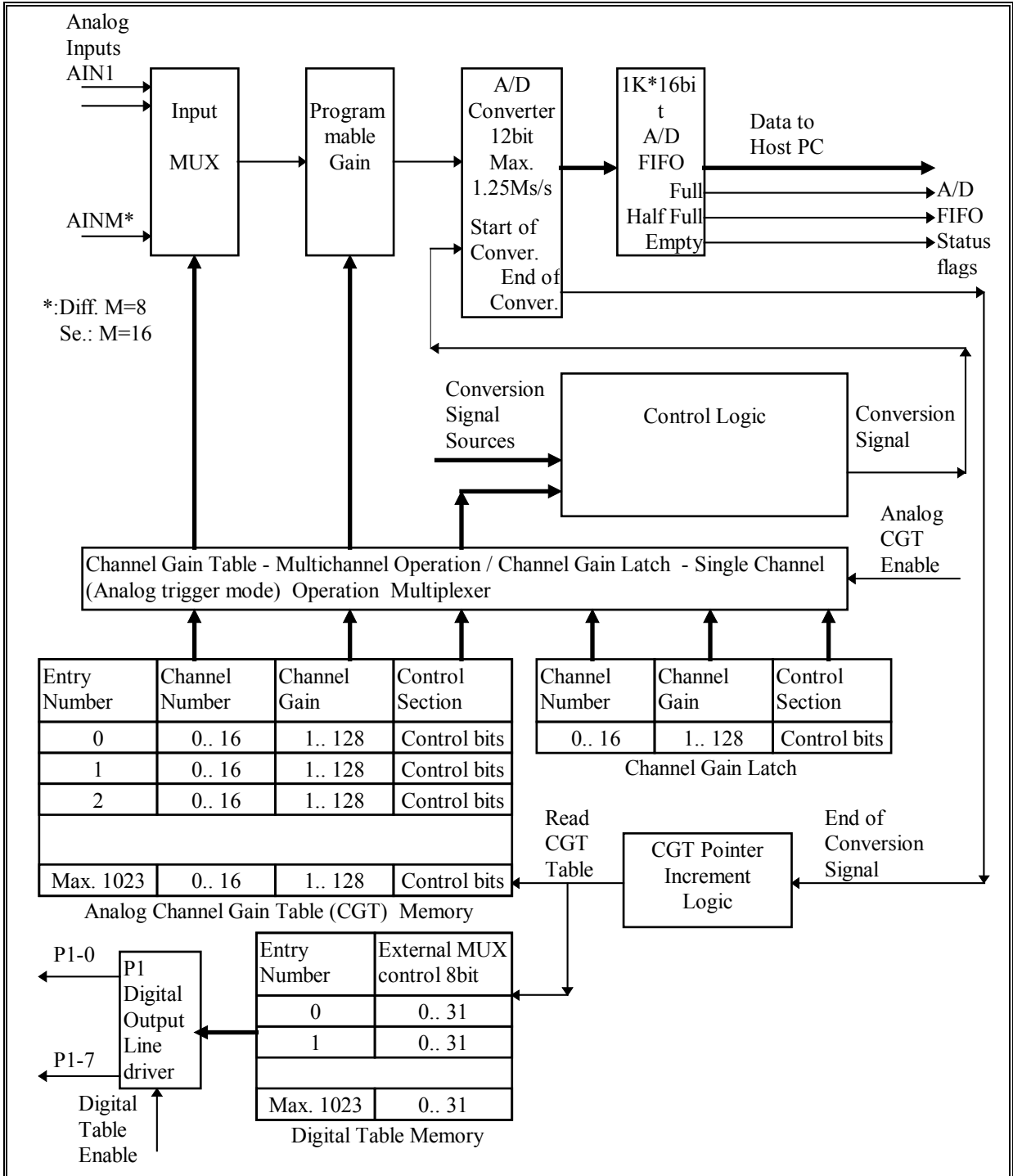

Figure 3.1.1.

### 3.1.3. A/D Converter

The 12-bit successive approximation A/D converter accurately digitizes dynamic input voltages in 0.8 microseconds, for a maximum throughput rate of 1.25 MHz. The converter IC contains a sample-and-hold amplifier, a 12-bit A/D converter, a 2.5-volt reference, a clock, and a digital interface to provide a

complete A/D conversion function on a single chip. Its low power CMOS logic combined with a high precision, low noise design give you accurate results.

Conversions are controlled by software command, by pacer clock, by using triggers to start and stop sampling, or by the sample counter to acquire a specified number of samples. An on-board or external pacer clock can be used to control the conversion rate. Conversion modes are described in Chapter 5, A/D Conversions.

#### **3.1.4. A/D FIFO - Sample Buffer**

A first in, first out (FIFO) 1024 sample buffer helps your computer manage the high throughput rate of the A/D converter by providing an elastic storage bin for the converted data. Even if the computer does not read the data as fast as conversions are performed, conversions will continue until a FIFO full flag is sent to stop the converter.

The sample buffer does not need to be addressed when you are writing to or reading from it; internal addressing makes sure that the data is properly stored and retrieved. All data accumulated in the sample buffer is stored intact until the PC is able to complete the data transfer. Its asynchronous operation means that data can be written to or read from it at any time, at any rate. When a transfer does begin, the data first placed in the FIFO is the first data out.

#### **3.1.5. Data Transfer**

The converted data can be transferred to PC memory in one of three ways. Data can be transferred using the programmed I/O mode, the interrupt mode or using the on-board DMA controller. A special interrupt mode using a REP INS (Repeat Input String) instruction supports very high speed data transfers. By generating an interrupt when the FIFO's half full flag is set, a REP INS instruction can be executed, transferring data to PC memory and emptying the sample buffer at the maximum rate allowed by the data bus. The DMA mode assures the fastest burst mode busmaster data transfer.

### 3.1.6. High-Speed Digital Input section

The Figure 3.1.2. shows the block diagram of High-Speed Digital Input section. The sampling signal can be software selectable.

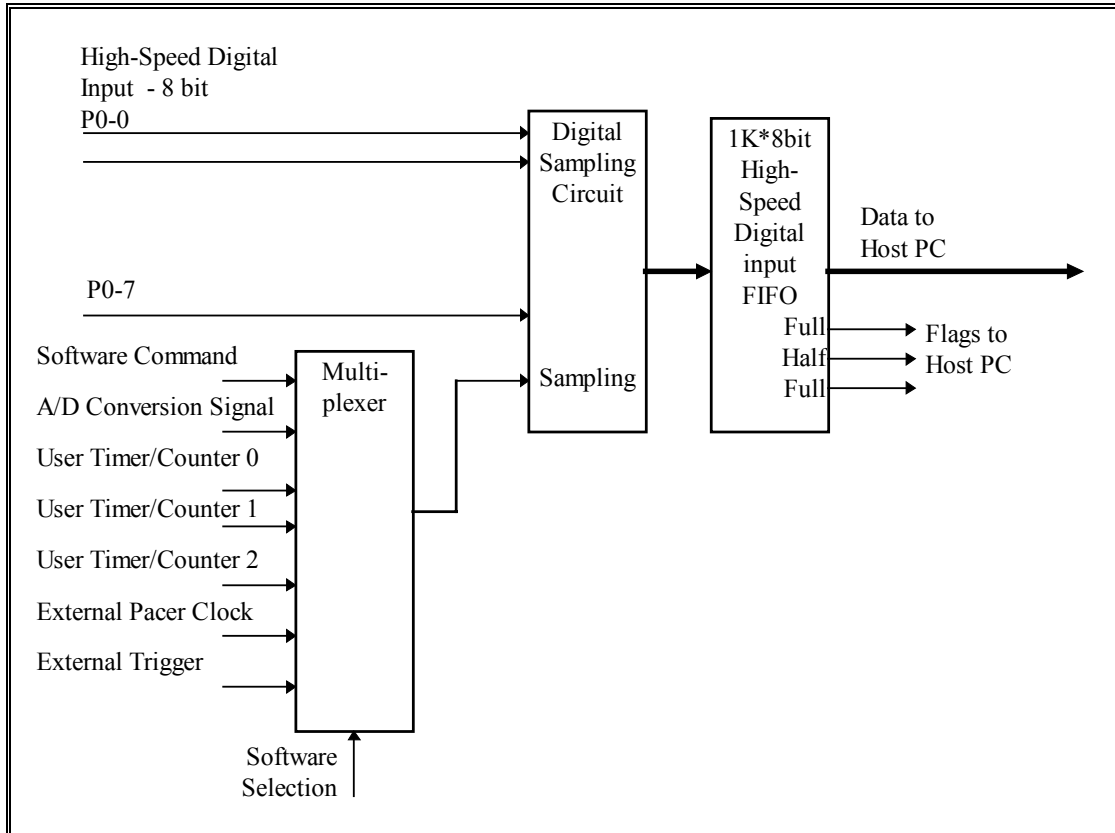

Figure 3.1.2.

The Sampled data are written automatically to the High-Speed Digital Input FIFO. Data can be transferred to PC memory in one of two ways. Data can be transferred using the programmed I/O mode, the interrupt mode or using the on-board DMA controller. The Interrupt mode assures the possibility getting Interrupt after an appropriate number of data. The number of data in High-Speed Digital Input FIFO can be counted by the User TC1. User TC1 can be an interrupt Source.

### 3.2. The Operation of Analog Output

The digital-to-analog (D/A) circuitry features two independent 12-bit analog output channels with individually programmable output ranges of -5 to +5 volts, 0 to +5 volts, -10 to +10 volts or 0 to +10 volts. Each channel has its own 1024 sample buffer for data storage before being output. Data can be continuously written to the buffer producing a non-repetitive output waveform or a set of data can be written into the buffer and continuously cycled to produce a repeating waveform. Data can be written into the output buffers by memory write instruction or by DMA transfer. Updating of the analog outputs can be done through software or by several different clocks and triggers. The outputs can be updated simultaneously or independently.

### 3.3. Timer/ Counters

One 8254 programmable 16-bit, 8-MHz interval timer, and internal 10.. 16 bit timers provide to support a wide range of timing and counting functions.

The internal timers works in binary count down mode.

The 8254 is the User TC. All three counters on this chip are available for user functions. Each 16-bit timer/counter has two inputs, CLK in and GATE in, and one output, timer/counter OUT. The sources of User TC clock and gate inputs can be programmed. Each TC can be programmed as binary or BCD down counters by writing the appropriate data to the command word, as described in Chapter 4. The command word also lets you set up the mode of operation. The six programmable modes are:

Mode 0 Event Counter (Interrupt on Terminal Count)

Mode 1 Hardware-Retriggerable One-Shot

Mode 2 Rate Generator

Mode 3 Square Wave Mode

Mode 4 Software-Triggered Strobe

Mode 5 Hardware Triggered Strobe (Retriggerable)

These modes are detailed in the 8254 Data Sheet, reprinted from Intel in Appendix C.

### 3.4. Digital I/O

The 16 digital I/O lines can be used to transfer data between the computer and external devices. Eight lines are bit programmable and eight lines are byte, or port, programmable.

Port 0 provides eight bit programmable lines which can be independently set for input or output. These ports support RTD's two Advanced Digital Interrupt modes. An interrupt can be generated when the lines match a programmed value or when any bit changes its current state. A Mask Register lets you monitor selected lines for interrupt generation.

Port 1 can be programmed as an 8-bit input or output port.

Chapter 10 details digital I/O operations and Chapter 8 explains digital interrupts.

### 3.5. SyncBus

The SyncBus is an RTD defined bus for synchronous operation with other RTD's boards. The SyncBus connector is the (10 pin right-angle 100mil header) P3 Connector at the right top corner of the board. The SyncBus is TTL signaling level and 5V compliant. See Table 4.2.1.f.

## 4. Register Address Spaces of PCI4520/DM7520/DM7540

The PCI4520/DM7520/DM7540 is a PCI bus board with a PCI Bus Master Interface. The board has four configuration register areas and two operation register areas.

The configuration Registers are the PCI Configuration Register and the Local Configuration Register, the Runtime Registers and the DMA Registers.

The PCI Configuration Registers, Runtime Registers and the Local Configuration Registers are filled out from an EEPROM on the board after power up. The description of the registers and the content of the EEPROM can be found in the Appendix.

The most interesting areas for the user - described in this Chapter - are the operation register address spaces of the board. There are two operation address spaces, the Local Address Space 0.. 1 LAS0, LAS1. These spaces can be accessed by memory instructions and - in the case of LAS1 - the on-board DMA controller. The base addresses of these spaces can be read from the PCI configuration area.

LAS0 is a 512 byte long 32 bit wide memory-mapped area. It can be used to runtime control and setup, configure of the PCI4520/DM7520/DM7540 board.

LAS1 is a 16 byte long 16 bit wide register area for transferring data from/to the board.

The Runtime registers can be used to control the EEPROM access, and the Interrupt operation of the board.

The DMA registers can be used to control the two-channel on-board DMA controllers to make fast data transfer between the FIFOs and the PC.

#### 4. 1. Local Address Space 0 (LAS0) - Runtime Area

The LAS0 memory mapped address space can be used to runtime control, setup, and configure the PCI4520/DM7520/DM7540 board. It is a 32 bit wide area, it can be accessed by Lword, Word, or Byte wide direct slave single cycle memory read or write instructions. This area *cannot* be burst read or written. Range size is 128 Lword, 512 byte. The LAS0 area is divided into two parts. These are the Runtime and the Setup Area. The Runtime Area of LAS0 is on the Table 4.1.2.:

| Address<br>LAS0 base<br>offset (hexa) | Local Address Space<br>0 |
|---------------------------------------|--------------------------|
| 000<br>0FF                            | Runtime Area             |
| 100<br>1FF                            | Setup Area               |

Table 4.1.1.

| Read Function   | Write Function                                | Local Address<br>Space 0 Offset |
|---|---|---------------------------------|
| Read Master / Target<br>Only mode jumper<br>(JP1) (DM7520/40<br>only) | I2C Clock line Write                          | 000h                            |
| I2C Data line Read  | I2C Data line Write                           | 004h                            |
| Read User Inputs  | Write User Outputs                            | 008h                            |
| Software DAC clock<br>Start   | Software DAC clock Stop                       | 00Ch                            |
| Read FIFO Status  | Software A/D Start                            | 010h                            |
| -   | Software D/A1 Update                          | 014h                            |
| -   | Software D/A2 Update                          | 018h                            |
| -   | -   | 01Ch                            |
| -   | -   | 020h                            |
| -   | Software Simultaneous<br>D/A1 and D/A2 Update | 024h                            |
| Software Pacer Start  | Software Pacer Stop                           | 028h                            |
| Read Timer Counters<br>Status   | Software high-speed input<br>Sample Command   | 02Ch                            |
| Read Interrupt Status   | Write Interrupt Enable<br>Mask Register       | 030h                            |
| Clear Interrupt set by<br>the Clear Mask                              | Set Interrupt Clear Mask                      | 034h                            |
| Read Interrupt Overrun<br>Register                                    | Clear Interrupt Overrun<br>Register           | 038h                            |
| -   | I2C Data line Write<br>enable                 | 03Ch                            |

Table 4.1.2.

The Timer/Counter section and the Digital I/O section of the Runtime Area:

| <b>Read Function</b>  | <b>Write Function</b>  | <b>Local Address Space 0 Offset</b> |
|---|--|-------------------------------------|
| Read <i>Pacer Clock</i> Counter value (24 bit)                                | Load count in <i>Pacer Clock</i> Counter (24 bit)                          | 040h                                |
| Read <i>Burst Clock</i> Counter value<br>16bit                                | Load count in <i>Burst Clock</i> Counter<br>16bit                          | 044h                                |
| Read <i>A/D Sample counter</i> value<br>16bit                                 | Load count in <i>A/D Sample counter</i><br>16bit                           | 048h                                |
| Read <i>D/A1 Update counter</i> value<br>16bit                                | Load count in <i>D/A1 Update counter</i><br>16bit                          | 04Ch                                |
| Read <i>D/A2 Update counter</i> value<br>16bit                                | Load count in <i>D/A2 Update counter</i><br>16bit                          | 050h                                |
| Read <i>Delay Counter</i> value<br>16 bit                                     | Load count in <i>Delay Counter</i><br>16 bit                               | 054h                                |
| Read <i>About Counter</i> value<br>16 bit                                     | Load count in <i>About Counter</i><br>16 bit                               | 058h                                |
| Read <i>DAC clock</i> value<br>16 bit – PCI4520<br>24 bit – DM7520/7540       | Load count in <i>DAC clock</i><br>16 bit – PCI4520<br>24 bit – DM7520/7540 | 05Ch                                |
| Read 8254 <i>User TC 0</i> value  | Load count in 8254 <i>User TC 0</i>  | 060h                                |
| Read 8254 <i>User TC 1</i> value  | Load count in 8254 <i>User TC 1</i>  | 064h                                |
| Read 8254 <i>User TC 2</i> value  | Load count in 8254 <i>User TC 2</i>  | 068h                                |
| Reserved  | Program counter mode for 8254 <i>User TC</i>                               | 06Ch                                |
| Read Port 0 digital input lines   | Program Port 0 digital output lines  | 070h                                |
| Read Port 1 digital input lines   | Program Port 1 digital output lines  | 074h                                |
| Clear digital IRQ status flag/read Port 0 direction, mask or compare register | Clear digital chip/program Port 0 direction, mask or compare register      | 078h                                |
| Read Digital I/O Status word  | Program Digital Control Register & Digital Interrupt enable                | 07Ch                                |

Table 4.1.3.

**4.1.1. Local Address Space 0 + 000h: Read Master / Target Only mode jumper (JP1) / Firmware version number - DM7520 Only (Read only)**

**Read operation (32-bit, one bit is used)**

A read provides the Read Master / Target Only mode jumper state as below.

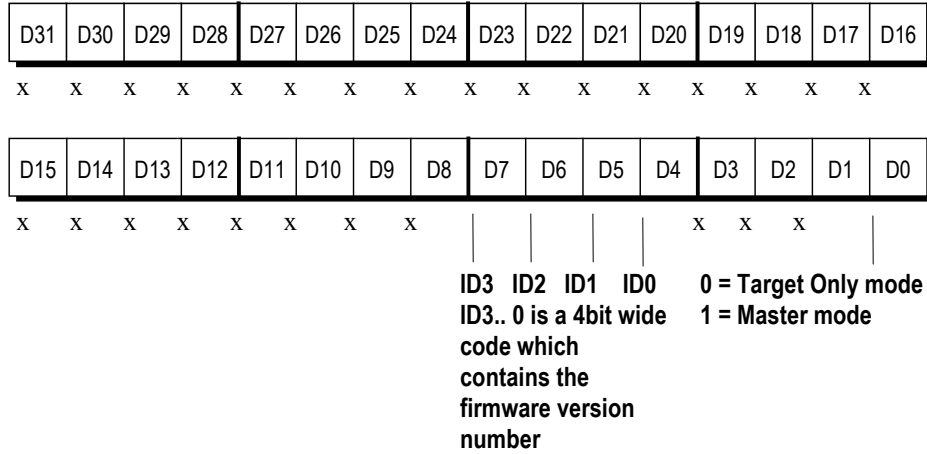

**4.1.2. Local Address Space 0 + 008h: User Input read / User Output Write (Read/write)**

**Read operation (32-bit, two bits are used)**

A read provides the User Input 0 and User Input 1 bits as below. These digital input lines come from the External I/O connector. The User Input bits are sampled by the read instruction.

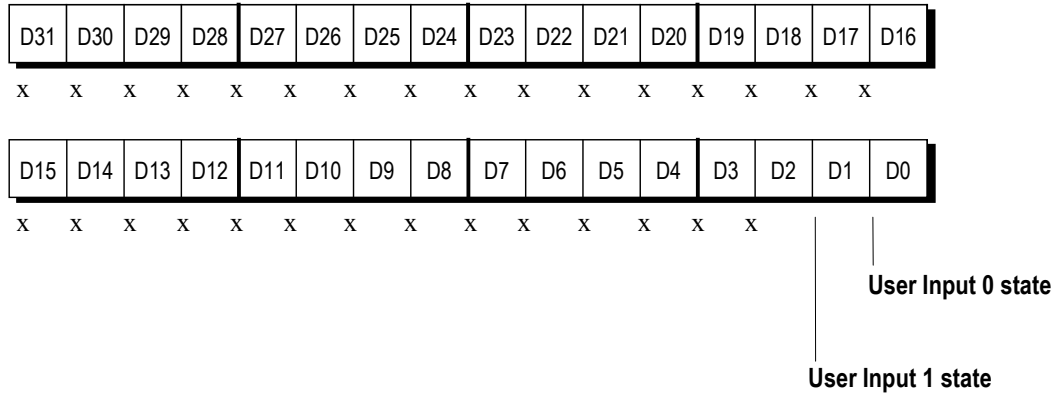

**Write operation (32-bit, two bits are used)**

These bits go to the External I/O connector of the board. If the source of the User Output x is set to the Software Programmable state by the 0x070E and 0x070F Functions, the state of the User Output bits can be programmed by this write operation.

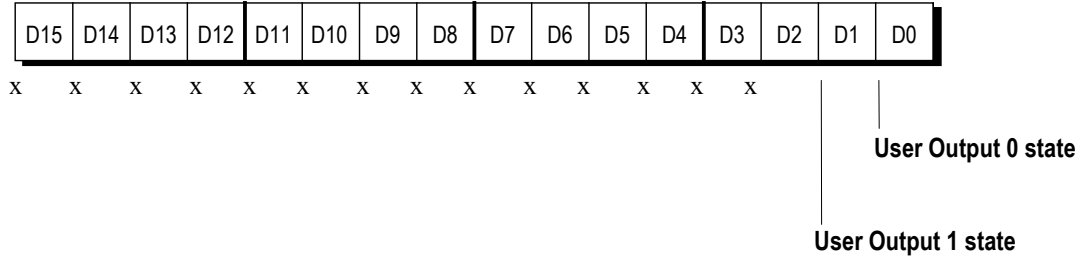

### 4.1.3. Local Address Space 0 + 010h: FIFO Status Register / A/D Conversion Start (Read/write)

#### Read operation (32-bit, upper word is not used)

A read provides the status bits of FIFOs as bellow.

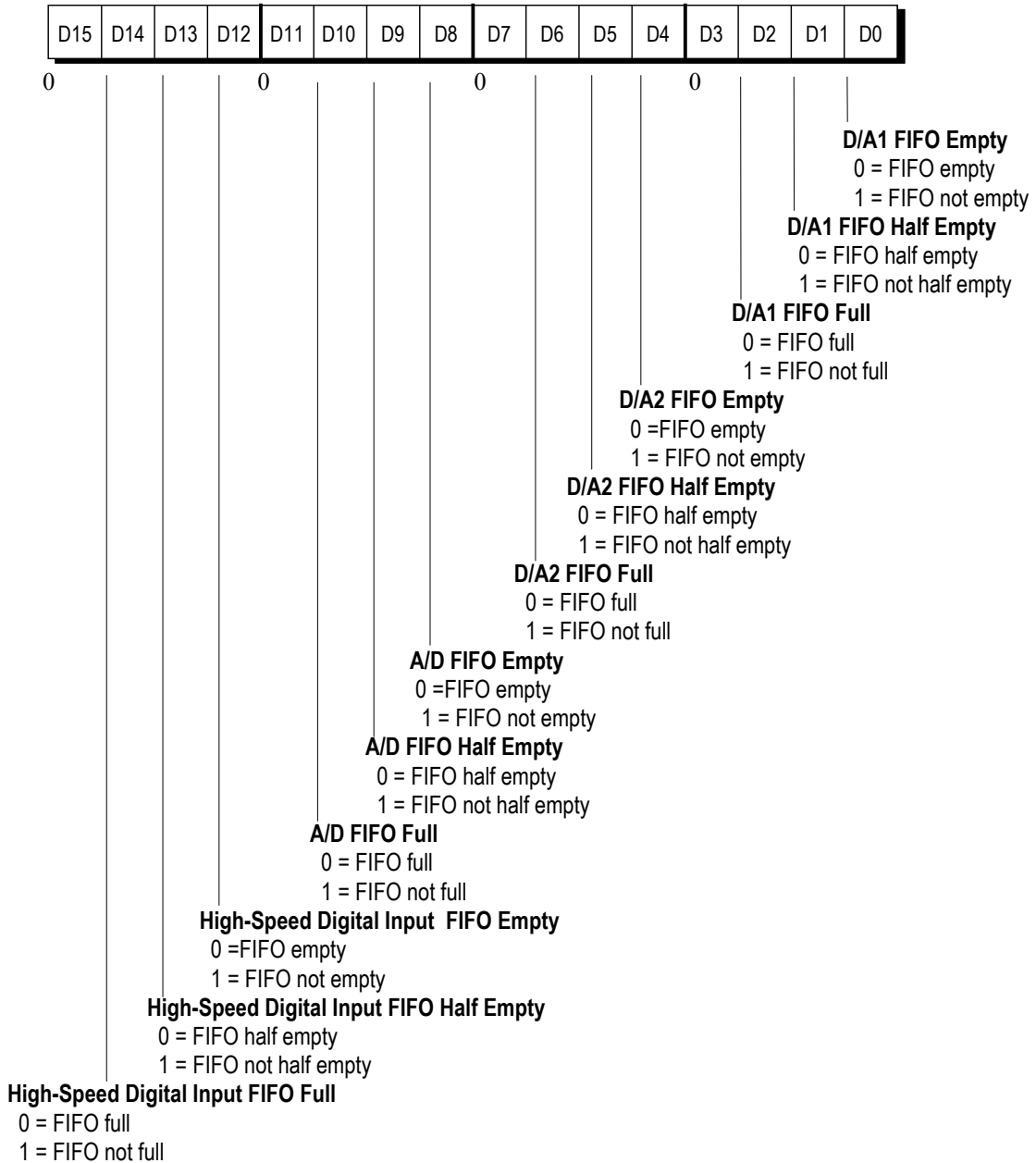

#### Write operation (16-bit)

A write means a Software A/D Start command. The written data does not care.

#### **4.1.4. Local Address Space 0 + 014h: Software update D/A1 (Write only)**

##### **Write operation (32-bit)**

A write updates the D/A1 if the update source is software update. The written data does not care. You can use byte, word or long word write instructions.

#### **4.1.5. Local Address Space 0 + 018h: Software update D/A2 (Write only)**

##### **Write operation (32-bit)**

A write updates the D/A2 if the update source is software update. The written data does not care. You can use byte, word or long word write instructions.

#### **4.1.6. Local Address Space 0 + 024h: Simultaneous Software Update D/A1 and D/A2 (Write only)**

##### **Write operation (32-bit)**

A write simultaneously updates the D/A1 and D/A2 converters if the update source is software update. The written data does not care. You can use byte, word or long word write instructions.

#### **4.1.7. Local Address Space 0 + 028h: Pacer Clock Software Start trigger / Pacer Clock Software Stop trigger (Read/Write)**

##### **Read operation (32-bit)**

A read means a software start trigger of the Pacer Clock if the start trigger source of the pacer clock is software trigger. The read data does not care.

##### **Write operation (32-bit)**

A write means a software stop trigger of the Pacer Clock if the stop trigger source of the pacer clock is software trigger. The written data does not care.

### 4.1.8. Local Address Space 0 + 02Ch: Pacer and Burst Clock Timer Status Register / Software High-speed Input Sample command (Read/Write)

#### Read operation (32-bit, upper word is not used)

A read provides the status of the gate of the Timer Counter circuits.

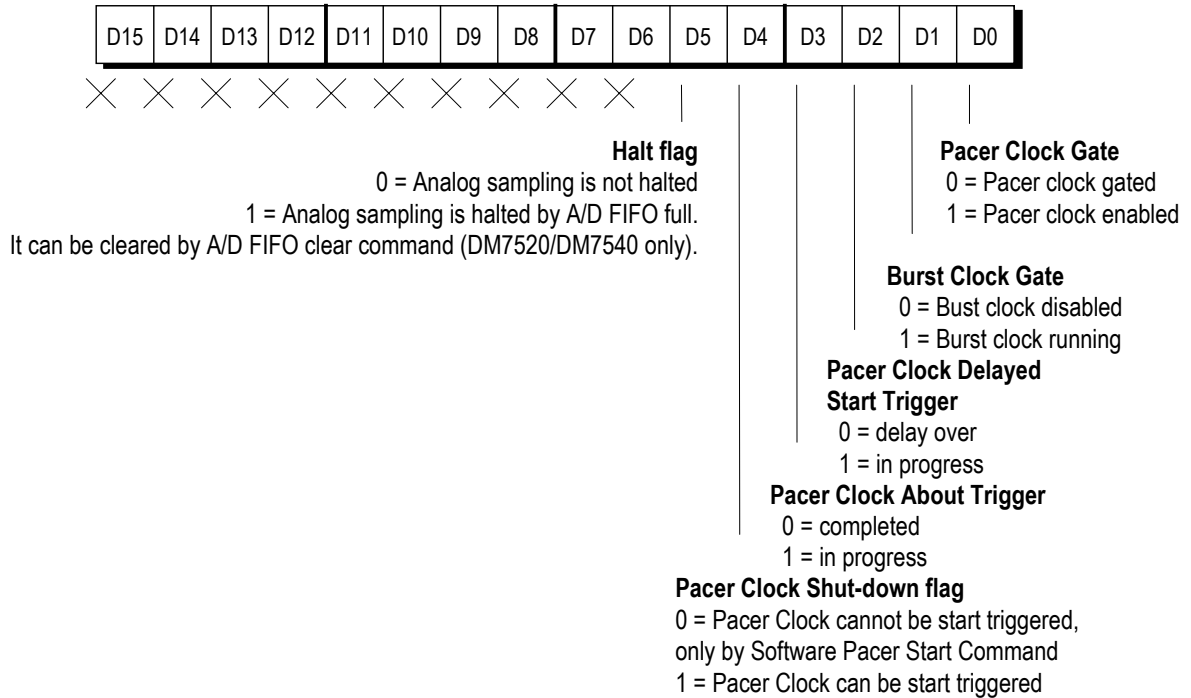

#### Write operation (32-bit)

A write means a software Sample command for 8 bit High-Speed Digital Input lines if the sampling source is the software command. This command means a High-Speed Digital Input FIFO write procedure. The written data does not care.

#### **4.1.9. Local Address Space 0 + 030h: Interrupt Status/Mask Register Read/write)**

The PCI4520/DM7520/DM7540 board has a built-in Priority Interrupt Controller that assures the possibility of multiply interrupt sources can generate interrupt ordered by their priority order. The highest priority is numbered by 0. The usage of the built-in Priority Interrupt controller is very easy:

1. Set the Interrupt Mask Register (Write LAS0 + 030h) in your initialization part of the software. Enable the required interrupt sources by ones
2. The built-in Priority Interrupt Controller orders the interrupt requests and transmits them to the PC. If an interrupt occurs, you can identify the active source by reading the Interrupt Status Register (Read LAS0 + 30h) in the Interrupt Service Routine. In the Interrupt Status Register always one bit is high indicating the active interrupt source. After identifying the source the request can be serviced.
3. Clear the serviced Interrupt request by the Interrupt Clear register. First write the clear mask writing the appropriate bit pattern to the address LAS0 + 034h. Then a dummy read from LAS0 + 034h executes the clear.

If you want to check that during servicing the interrupt a new interrupt has not come yet, after clearing the interrupt request read the Interrupt Overrun Register. Zero bits means, that all interrupt have been serviced correctly. One means that a new interrupt occurred before the previous service was finished. After reading the Interrupt Overrun Register clear it.

**Read operation (32 bit, upper word does not used)** A read provides the status flag of the interrupt.

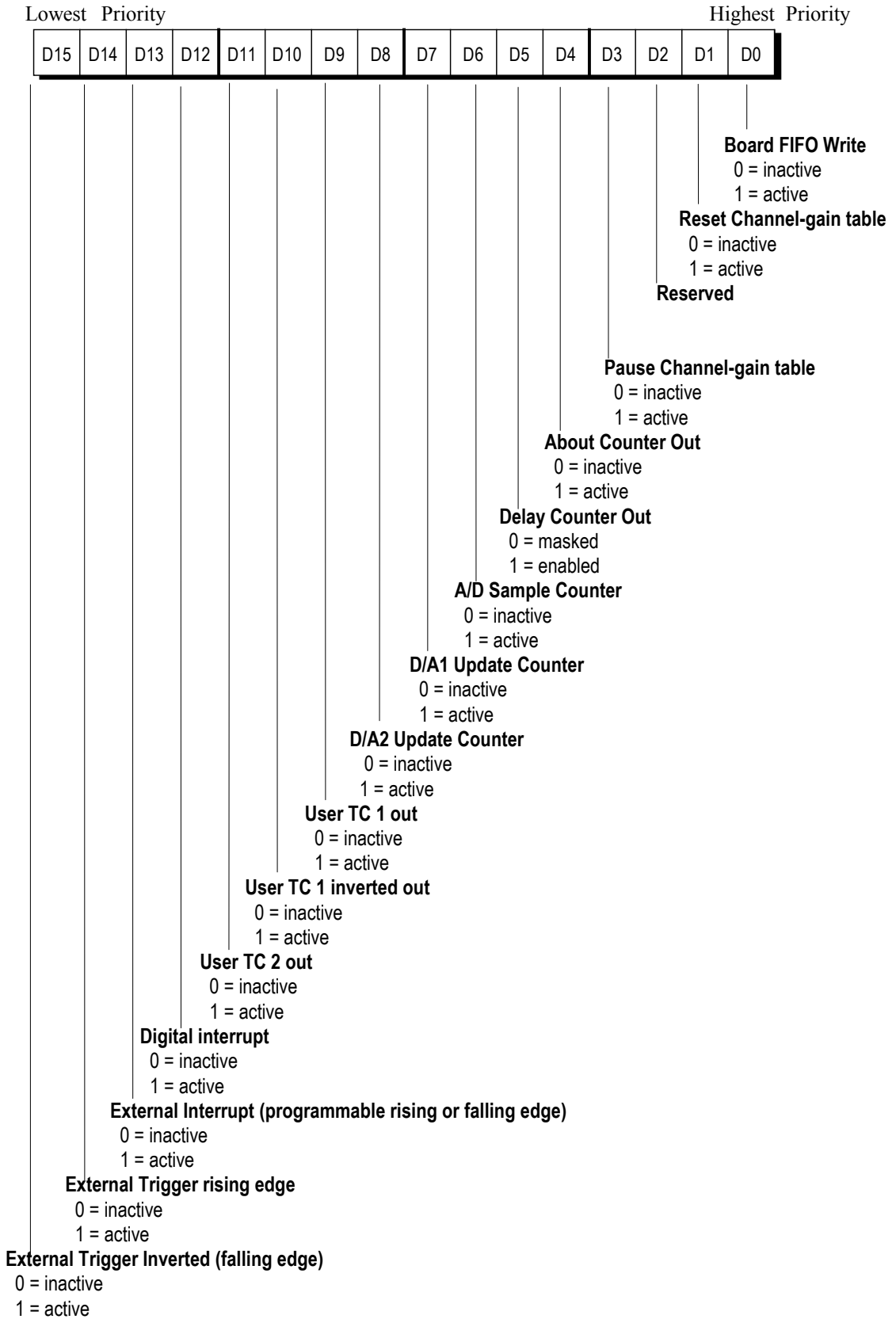

**Write operation (32 bit, upper word does not used)** The interrupt mask register:

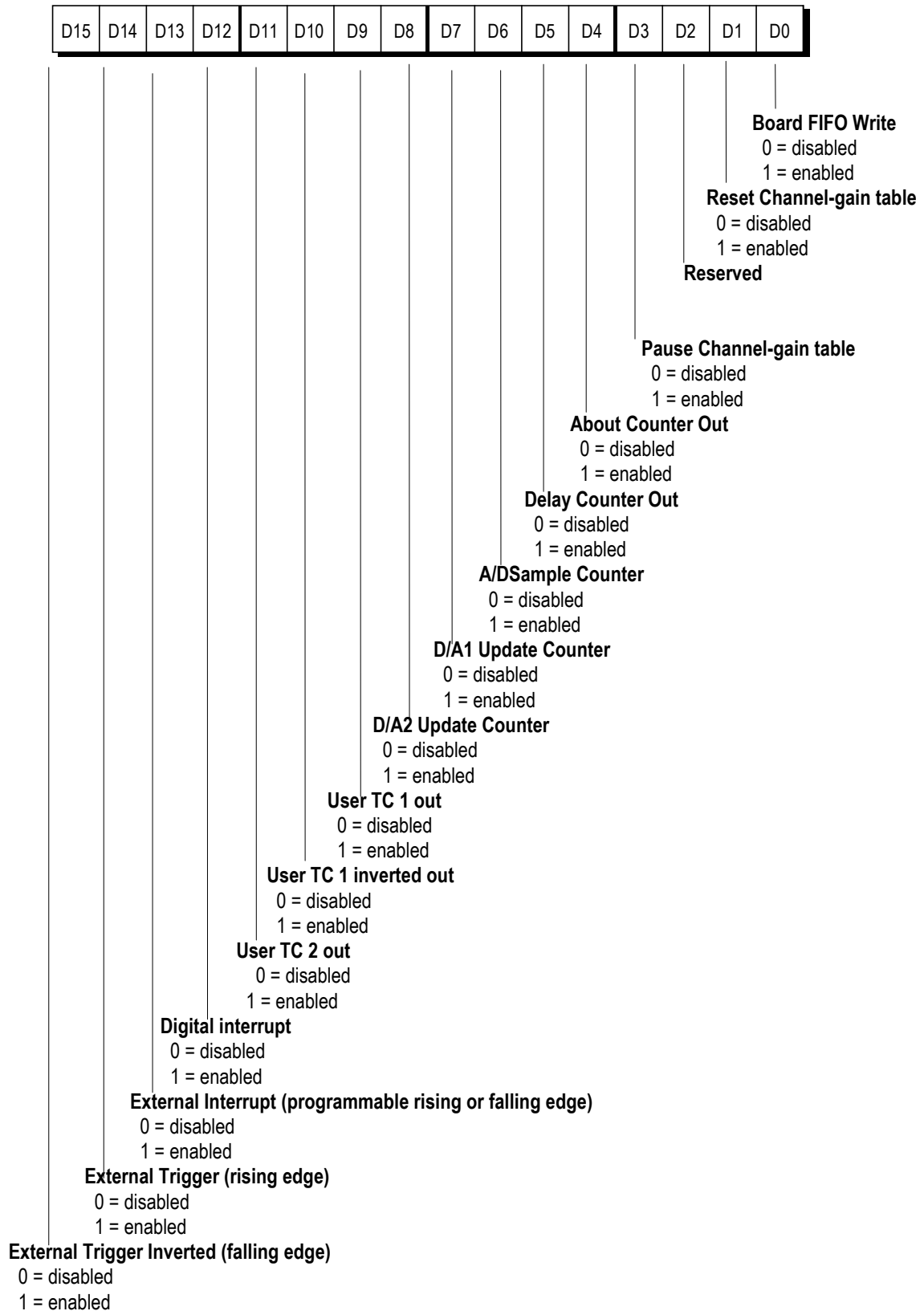





**Write operation (32 bit, upper word does not used)**

A write clears all bits of the Interrupt Overrun Register.

**Read operation (32 bit, upper word does not used)**

A read provides the Interrupt Overrun Register. If the interrupts serviced in time all bits are zeros. If a new interrupt request comes before the pervious has been serviced and the request is cleared, the appropriate overrun bit goes into high.

**4.1.12. Local Address Space 0 + 040h, Pacer Clock Counter (Read/Write)**

The Pacer Clock Counter is a 24 bit wide down counter synthesized in the control EPLD of the board. Its clock signal is the 10 or 8MHz clock. This primary frequency is initially 8MHz, but can be modified by writing LAS0+ xx. The output signal is the Pacer Clock signal, which is in high state during counting, except the zero state of the counter. If the counter value is zero, the Pacer clock output is in low state.

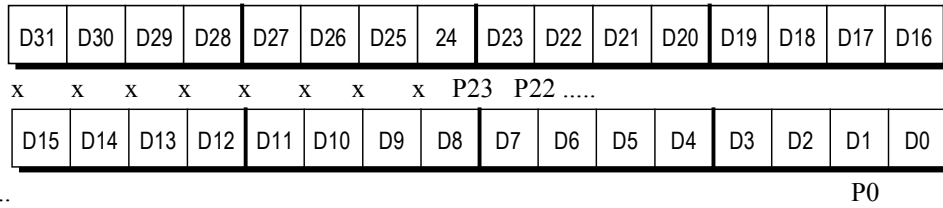

**Read operation (32bit ,24 bits are used)**

A read shows the 24bit Pacer Clock counter.

**Write operation 32bit ,24 bits are used)**

A write loads the 24 bit wide Pacer Clock counter. Down counting begins as soon as the count is loaded.

**4.1.13. Local Address Space 0 + 044h, Burst Clock Counter (Read/Write)**

The Burst Clock Counter is a 10 bit – PCI4520, 16bit – DM7520/DM7540 wide down counter synthesized in the control EPLD of the board. Its clock signal is the 8MHz clock. The output signal is the Burst Clock signal, which is in high state during counting, except the zero state of the counter. If the counter value is zero, the Burst clock output is in low state. The 10 bit wide burst clock counter assures the 7820Hz minimum Burst clock frequency.

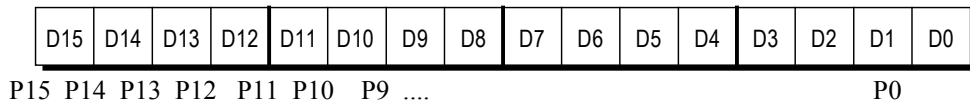

**Read operation (32bit, 10 (16) bit is used)**

A read shows the 10 (16) bit Burst Clock Counter.

**Write operation (32bit, 10 (16) bit is used)**

A write loads the 10 (16) bit wide Burst Clock Counter.

**4.1.14. Local Address Space 0 + 048h, A/D Sample Counter (Read/Write)**

The A/D Sample Counter is a 10 bit – PCI4520 16bit – DM7520 wide down counter synthesized in the control EPLD of the board. Its clock signal can be programmed by writing the LAS0 +170h address. The output signal is the A/D Sample Counter signal, which is in high state during counting, except the zero state of the counter. If the counter value is zero, the A/D Sample Counter output is in low state. The 10 bit wide A/D Sample Counter assures the 1024 (65536) maximum value of counting A/D samples.

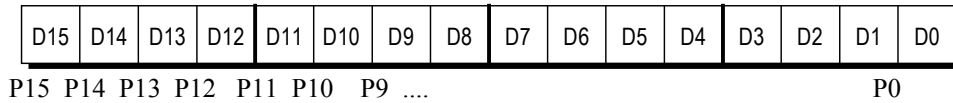

**Read operation (32bit, 10 (16) bit is used)**

A read shows the 10 bit A/D Sample Counter.

**Write operation (32bit, 10 (16) bit is used)**

A write loads the 10 (16) bit wide A/D Sample Counter.

**4.1.15. Local Address Space 0 + 04Ch, D/A1 Update Counter (Read/Write)**

The D/A1 Update Counter is a 10(16) bit wide down counter synthesized in the control EPLD of the board. Its clock signal is the D/A1 update signal. The output signal is the D/A1 Update Counter signal, which is in high state during counting, except the zero state of the counter. If the counter value is zero, the D/A1 Update Counter output is in low state. The 10 bit wide D/A1 Update Counter assures the 1024 maximum value of counting D/A1 updates.

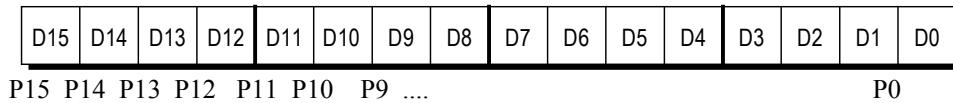

**Read operation (32bit, 10 bit is used)**

A read shows the 10 bit D/A1 Update Counter.

**Write operation (32bit, 10 bit is used)**

A write loads the 10 bit wide D/A1 Update Counter.

**4.1.16. Local Address Space 0 + 050h, D/A2 Update Counter (Read/Write)**

The D/A2 Update Counter is a 10 bit – PCI4520 16bit – DM7520 wide down counter synthesized in the control EPLD of the board. Its clock signal is the D/A2 update signal. The output signal is the D/A2 Update Counter signal, which is in high state during counting, except the zero state of the counter. If the counter value is zero, the D/A2 Update Counter output is in low state. The 10 bit wide D/A2 Update Counter assures the 1024 (65536) maximum value of counting D/A2 updates.

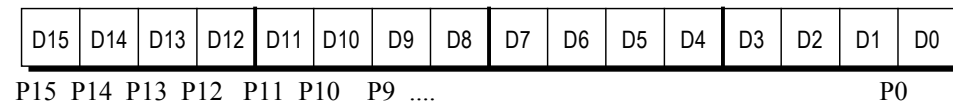

**Read operation (32bit, 10 (16) bit is used)**

A read shows the 10 (16) bit D/A2 Update Counter.

**Write operation (32bit, 10 (16) bit is used)**

A write loads the 10 bit wide D/A2 Update Counter.

**4.1.17. Local Address Space 0 + 054h, Delay Counter (Read/Write)**

The Delay Counter is a 16 bit wide down counter synthesized in the control EPLD of the board. Its clock signal is the same frequency clock signal as the Pacer Clock. During the down counting process the Pacer clock is shut down. The 16 bit wide Delay Counter assures the 65535 maximum value of Pacer clock period delaying the Start Pacer Clock..

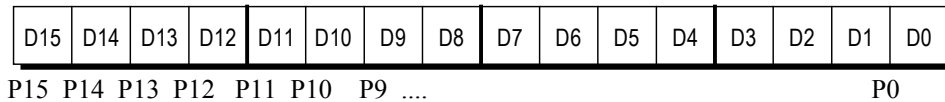

**Read operation (32bit, 16 bit is used)**

A read shows the 16 bit Delay Counter.

**Write operation (32bit, 16 bit is used)**

A write loads the 16 bit wide Delay Counter.

**4.1.18. Local Address Space 0 + 058h, About Counter (Read/Write)**

The About Counter is used for delayed Pacer Clock Stop function. If the sampling clock is the Pacer Clock the number of samples to acquire after stop trigger is programmed in the About Counter. The about Counter is a 16 bit wide down counter synthesized in the control EPLD of the board. The 16 bit wide About Counter assures the 65535 maximum value of samples delaying the Stop Pacer Clock..

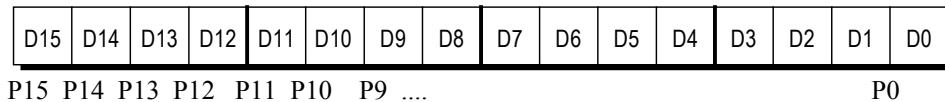

**Read operation (32bit, 16 bit is used)**

A read shows the 16 bit About Counter.

**Write operation (32bit, 16 bit is used)**

A write loads the 16 bit wide About Counter.

**4.1.19. Local Address Space 0 + 05Ch, DAC Clock Counter (Read/Write)**

The DAC Clock Counter is a 16 bit wide down counter synthesized in the control EPLD of the board. Its clock signal is the 8 / 20MHz clock. The output signal is the DAC Clock signal , which is in high state during counting, except the zero state of the counter. If the counter value is zero , the DAC clock output is in low state. The DAC Clock may be the update signal of the D/A converters.

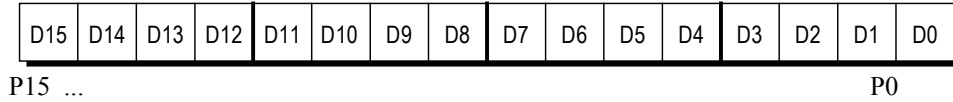
**Read operation (32bit ,16 bit is used)**

A read shows the 16bit DAC Clock Counter.

**Write operation 32bit ,16 bit is used)**

A write loads the 16 bit wide DAC Clock Counter. Down counting begins as soon as the count is loaded.

**4.1.20. Local Address Space 0 + 060h, 064h, 068h: User Timer/Counter 0, 1, 2 (Read/Write)**

The PCI4520/DM7520/DM7540 DAQ Board has an 8254 Timer Counter chip for the user. The clock sources and gates can be programmed.

**Read operation (2 times 8-bit)**

A read in two 8-bit steps shows the count in the User Timer Counter 0, 1, 2.

**Write operation (2 times 8-bit)**

A write loads the User Timer Counter 0, 1, 2 with a new 16 bit value in two 8-bit steps, LSB followed by MSB. The counter must be loaded in two 8-bit steps!

### 4.1.21. Local Address Space 0 + 06Ch User Timer/Counter control word (Write Only)

**Write operation (32bit, 8 bits are used)**

Accesses the timer/counter's control register to directly control the three 16-bit counters, 0, 1, and 2.

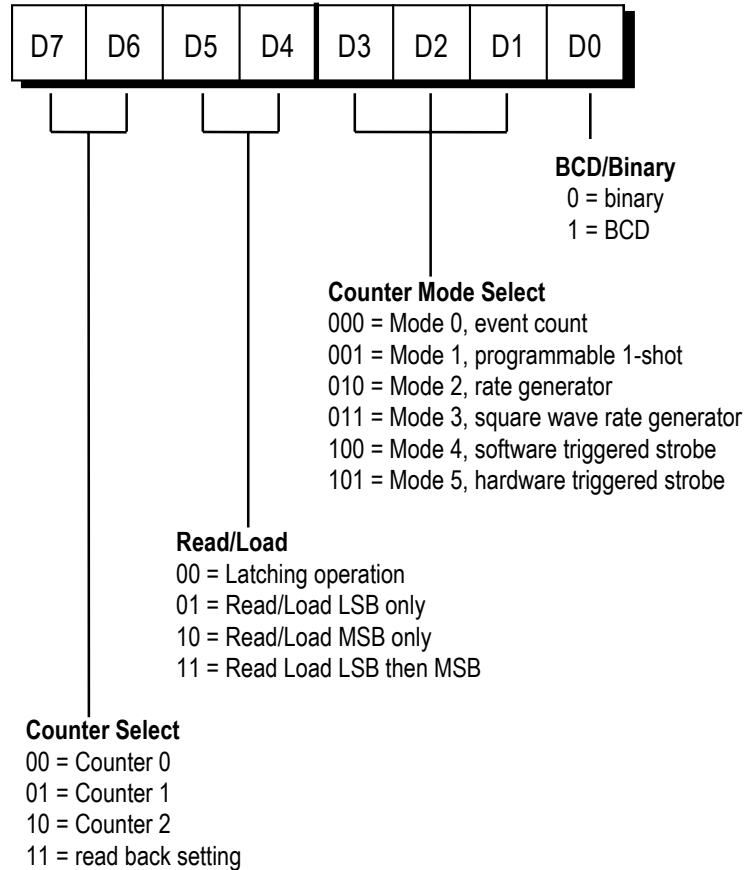

### 4.1.22. Local Address Space 2 + 070h - Digital I/O chip Port 0, Bit Programmable Port (Read/Write)

32bit, 8bits are used.

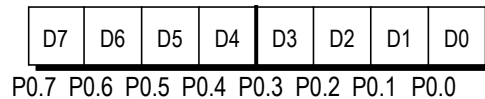

This port transfers the 8-bit Port 0 bit programmable digital input/output data between the board and external devices. The bits are individually programmed as input or output by writing to the Direction Register at LAS0+078h. For all bits set as inputs, a read reads the input values and a write is ignored. For all bits set as outputs, a read reads the last value sent out on the line and a write writes the current loaded value out to the line.

Note that when any reset of the digital circuitry is performed (clear chip or computer reset), all digital lines are reset to inputs and their corresponding output registers are cleared.

#### 4.1.23. Local Address Space 0 + 074h - Digital I/O chip Port 1, Byte Programmable Port (Read/Write)

32bit, 8bits are used.

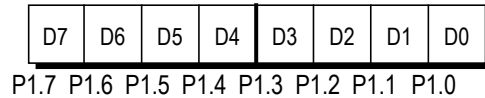

This port transfers the 8-bit Port 1 digital input or digital output byte between the board and an external device. When Port 1 is set as inputs, a read reads the input values and a write is ignored. When Port 1 is set as outputs, a read reads the last value sent out of the port and a write writes the current loaded value out of the port.

Note that when any reset of the digital circuitry is performed (clear chip or computer reset), all digital lines are reset to inputs and their corresponding output registers are cleared.

#### 4.1.24. Local Address Space 0 + 78h - Read/Program Port 0 Direction/ Mask/ Compare Registers (Read/Write)

32bit, 8bits are used.

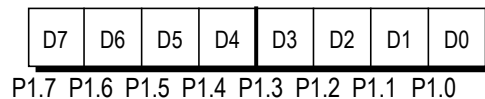

A read clears the IRQ status flag or provides the contents of one of digital I/O Port 0's three control registers; and a write clears the digital chip or programs one of the three control registers, depending on the setting of bits 0 and 1 at LAS0 + 07Ch. When bits 1 and 0 at LAS0 + 07Ch are 00, the read/write operations clear the digital IRQ status flag (read) and the digital chip (write). When these bits are set to any other value, one of the three Port 0 registers is addressed.

##### Direction Register (LAS0 + 07Ch, bits 1 and 0 = 01):

This register programs the direction, input or output, of each bit at Port 0.

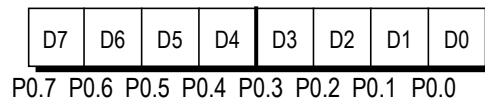

For all bits:

0 = input

1 = output

##### Mask Register (LAS0 +07Ch, bits 1 and 0 = 10):

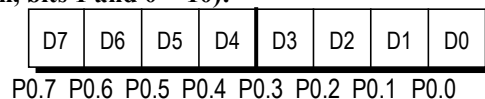

For all bits:

0 = bit enabled

1 = bit masked

In the Advanced Digital Interrupt modes, this register is used to mask out specific bits when monitoring the bit pattern present at Port 0 for interrupt generation. In normal operation where the Advanced Digital Interrupt feature is not being used, any bit which is masked by writing a 1 to that bit will

not change state, regardless of the digital data written to Port 0. For example, if you set the state of bit 0 low and then mask this bit, the state will remain low, regardless of what you output at Port 0 (an output of 1 will not change the bit's state until the bit is unmasked).

**Compare Register (LAS0 + 07Ch, bits 1 and 0 = 11):**

This register is used for the Advanced Digital Interrupt modes. In the match mode where an interrupt is generated when the Port 0 bits match a loaded value, this register is used to load the bit pattern to be matched at Port 0. Bits can be selectively masked so that they are ignored when making a match. NOTE: Make sure that bit 3 at LAS0 + 07Ch is set to 1, selecting match mode, BEFORE writing the Compare Register value at this address. In the event mode where an interrupt is generated when any Port 0 bit changes its current state, the value which caused the interrupt is latched at this register and can be read from it. Bits can be selectively masked using the Mask Register so a change of state is ignored on these lines in the event mode.

### 4.1.25. Local Address Space 0 + 07Ch - Read Digital IRQ Status/Program Digital Mode (Read/Write)

32bit, 8bits are used.

#### Digital IRQ/Strobe Status (Read):

A read shows you whether a digital interrupt has occurred (bit 6), whether a strobe has occurred (bit 7, when using the strobe input as described in Chapter 7), and lets you review the states of bits 0 through 5 in this register. If bit 6 is high, then a digital interrupt has taken place. If bit 7 is high, a strobe has been issued.

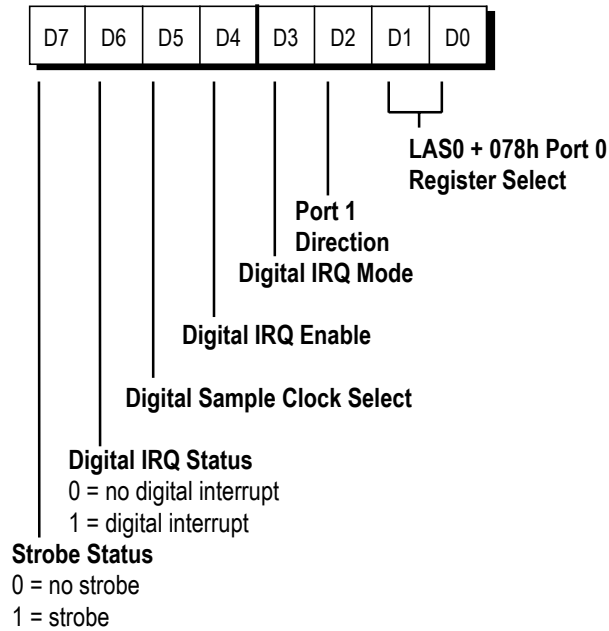

#### Digital Mode Register (Write):

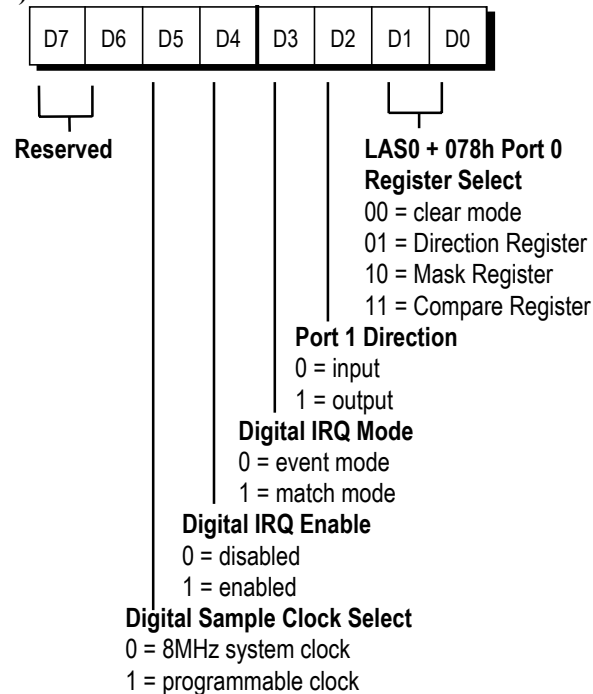

Bits 0 and 1 – Select the clear mode initiated by a read/write operation at LAS0 + 078h or the Port 0 control register you talk to at LAS + 078h (Direction, Mask, or Compare Register).

Bit 2 – Sets the direction of the Port 1 digital lines.

Bit 3 – Selects the digital interrupt mode: event (any Port 0 bit changes state) or match (Port 0 lines match the value programmed into the Compare Register at LAS0 + 078h).

Bit 4 – Disables/enables digital interrupts.

Bit 5 – Sets the clock rate at which the digital lines are sampled when in a digital interrupt mode. Available clock sources are the 8 MHz system clock and the output of User TC Counter 1 (16-bit programmable clock). When a digital input line changes state, it must stay at the new state for two edges of the clock pulse (62.5 nanoseconds when using the 8 MHz clock) before it is recognized and before an interrupt can be generated. This feature eliminates noise glitches that can cause a false state change on an input line and generate an unwanted interrupt. This feature is detailed in Chapter 7.

Bit 6 – Reserved.

Bit 7 – Reserved.

### 4. 2. Local Address Space 0 (LAS0) - Setup Area

The LAS0 Setup Area (LAS0 + 100.. 1FF) is used to program the operating modes of PCI4520/DM7520/DM7540 Board. The functionality of this area is the same as the Function Select / Argument of older PCI4400 board. The following tables show the programming possibilities of the DAQ board.

After power up the registers of PCI4520/DM7520/DM7540 is in initial state. This initial state can be reached also by Software Reset. The initial state is signed by .

The 4.2.1. Table show the LAS0 Setup area. Function Code are the PCI4400 style Function Code Function select Code information.



| Function group          | Function name               | LAS0 Offset Address / Function code (hex) | Function argument  |
|-------------------------|-----------------------------|---|--|
| Board Control           | Software Reset of the board | 100h<br>0x000F                            | -  |
| Demand Mode DMA Control | DMA0 Request source Select  | 104h<br>0x0100                            | 0x00 = Request disable <br>0x01 = A/D Sample Counter<br>0x02 = D/A1 Sample Counter<br>0x03 = D/A2 Sample Counter<br>0x04 = User TC 1<br>0x08 = A/D FIFO half full<br>0x09 = D/A1 FIFO half Empty<br>0x0A = D/A2 FIFO half Empty |
|                         | DMA1 Request source Select  | 108h<br>0x0101                            | 0x00 = Request disable <br>0x01 = A/D Sample Counter<br>0x02 = D/A1 Sample Counter<br>0x03 = D/A2 Sample Counter<br>0x04 = User TC 1<br>0x08 = A/D FIFO half full<br>0x09 = D/A1 FIFO half Empty<br>0x0A = D/A2 FIFO half Empty |
|                         | Reset DMA0 Request machine  | 1CCh<br>0x0710                            | -  |
|                         | Reset DMA1 Request machine  | 1D0h<br>0x0711                            | -  |

Table 4.2.1.a

|   |                                  |               |   |
|---|----------------------------------|---------------|---|
| A/D Conversion and High Speed Digital Input Control | A/D Conversion Signal Select     | 10C<br>0x0200 | 0x0 = Software A/D Start <sup>Ⓢ</sup><br>(WR_LAS0 + 010h)<br>0x1 = Pacer Clock<br>0x2 = Burst Clock<br>0x3 = Digital Interrupt<br>0x4 = D/A 1 Data Marker 1<br>0x5 = D/A 2 Data Marker 1<br>0x6 = SyncBus 0<br>0x7 = SyncBus 1<br>0x8 = SyncBus 2   |
|   | Burst Clock start trigger select | 110<br>0x0201 | 0x0 = Software A/D Start <sup>Ⓢ</sup><br>(WR_LAS0 + 010h)<br>0x1 = Pacer Clock<br>0x2 = External Trigger<br>0x3 = Digital Interrupt<br>0x4 = SyncBus 0<br>0x5 = SyncBus 1<br>0x6 = SyncBus 2  |
|   | Pacer Clock start trigger select | 114<br>0x0202 | 0x0 = Software Pacer Start <sup>Ⓢ</sup><br>(RD_LAS0 + 028h)<br>0x1 = External trigger<br>0x2 = Digital interrupt<br>0x3 = User TC 2 out<br>0x4 = SyncBus 0<br>0x5 = SyncBus 1<br>0x6 = SyncBus 2<br>0x7 = Reserved<br>0x8 = Delayed Software Pacer Start<br>0x9 = Delayed external trigger<br>0xA = Delayed digital interrupt<br>0xB = Delayed User TC 2 out<br>0xC = Delayed SyncBus 0<br>0xD = Delayed SyncBus 1<br>0xE = Delayed SyncBus 2<br>0xF = External Trigger Gated controlled mode |

Table 4.2.1.b





| Function group                                      | Function name                                       | LAS0 Offset Address / Function code (hex) | Function argument   |
|---|---|---|---|
| A/D Conversion and High Speed Digital Input Control | Pacer Clock Stop Trigger select                     | 118<br>0x0203                             | 0x0 = Software Pacer Stop <br>(WR_LAS0 + 028h)<br>0x1 = External Trigger<br>0x2 = Digital Interrupt<br>0x3 = About Counter<br>0x4 = User TC2 out<br>0x5 = SyncBus 0<br>0x6 = SyncBus 1<br>0x7 = SyncBus 2<br>0x8 = About Software Pacer Stop<br>0x9 = About External Trigger<br>0xA = About Digital Interrupt<br>0xB = Reserved<br>0xC = About User TC2 out<br>0xD = About SyncBus 0<br>0xE = About SyncBus 1<br>0xF = About SyncBus 2 |
|   | About Counter Stop Enable                           | 11C<br>0x0204                             | 0 = Stop enabled <br>1 = Stop disabled   |
|   | Pacer Start Trigger Mode select                     | 120<br>0x0205                             | 0x0 = Single Cycle Mode - new cycle can be possible after a Software Pacer Start command <br>0x1 = Trigger Repeat Mode - Pacer can be started by the selected Pacer Start Trigger  |
|   | Sampling Signal for High Speed Digital Input Select | 124<br>0x0206                             | 0x0 = Software (Write LAS0 + 02Ch)<br>0x1 = A/D Conversion Signal <br>0x2 = User TC out<br>0x3 = User TC out 1<br>0x4 = User TC out 2<br>0x5 = External Pacer Clock<br>0x6 = External Trigger  |
|   | Clear High Speed Digital Input FIFO                 | 128<br>0x020E                             | -   |
|   | Clear A/D FIFO                                      | 12C<br>0x020F                             | -   |

Table 4.2.1.c

| Function group                       | Function name                                  | LAS0 Offset Address / Function code (hex) | Function argument   |
|--------------------------------------|--|---|---|
| Channel Gain / Digital Table Control | Write Channel Gain Table (Multi-channel mode)  | 130h<br>0x0300                            | see 4.2.13.   |
|                                      | Write Channel Gain Latch (Single-channel mode) | 134h<br>0x0301                            | see 4.2.14.   |
|                                      | Write Digital Table (To control external MUX)  | 138h<br>0x0302                            | see 4.2.15.   |
|                                      | Enable Channel Gain Table                      | 13Ch<br>0x0303                            | 0x0 = Channel Gain Table disabled<br>☞<br>Channel Gain Latch enabled ☞<br>0x1 = Channel Gain Table enabled<br>Channel Gain Latch disabled |
|                                      | Enable Digital Table                           | 140h<br>0x0304                            | 0x0 = Digital Table disabled ☞<br>Digital I/O P1 port enabled ☞<br>0x1 = Digital Table enabled<br>Digital I/O P1 port disabled            |
|                                      | Table Pause enable                             | 144h<br>0x0305                            | 0x0 = Table Pause disabled ☞<br>0x1 = Table Pause enabled   |
|                                      | Reset Channel Gain Table                       | 148h<br>0x030E                            | -   |
|                                      | Clear Channel Gain Table                       | 14Ch<br>0x030F                            | -   |

Table 4.2.1.d

| Function group | Function name            | LAS0 Offset Address / Function code (hex) | Function argument   |
|----------------|--------------------------|---|---|
| D/A 1Control   | D/A1 output type / range | 150h<br>0x0400                            | 0x0 = unipolar 0..5V <sup>Ⓢ</sup><br>0x1 = unipolar 0.. 10V<br>0x2 = bipolar ±5V<br>0x3 = bipolar ±10V  |
|                | D/A1 update source       | 154h<br>0x0401                            | 0x0 = Software D/A1 Update <sup>Ⓢ</sup><br>0x1 = CGT controlled D/A1 Update<br>0x2 = D/A Clock<br>0x3 = External pacer clock<br>0x4 = SyncBus 0<br>0x5 = SyncBus 1<br>0x6 = SyncBus 2 |
|                | D/A1 Cycle Mode          | 158h<br>0x0402                            | 0x0 = not cycle <sup>Ⓢ</sup><br>0x1 = cycle   |
|                | Reset D/A1 FIFO          | 15Ch<br>0x0406                            | -   |
|                | Clear D/A1 FIFO          | 160h<br>0x0407                            | -   |
| D/A 2Control   | D/A2 output type / range | 164h<br>0x0408                            | 0x0 = unipolar 0..5V <sup>Ⓢ</sup><br>0x1 = unipolar 0.. 10V<br>0x2 = bipolar ±5V<br>0x3 = bipolar ±10V  |
|                | D/A2 update source       | 168h<br>0x0409                            | 0x0 = Software D/A2 Update <sup>Ⓢ</sup><br>0x1 = CGT controlled D/A2 Update<br>0x2 = D/A Clock<br>0x3 = External Pacer Clock<br>0x4 = SyncBus 0<br>0x5 = SyncBus 1<br>0x6 = SyncBus 2 |
|                | D/A2 Cycle Mode          | 16Ch<br>0x040A                            | 0x0 = not cycle <sup>Ⓢ</sup><br>0x1 = cycle   |
|                | Reset D/A2 FIFO          | 170h<br>0x040E                            | -   |
|                | Clear D/A2 FIFO          | 174h<br>0x040F                            | -   |

Table 4.2.1.e



|                   |  |                |  |
|-------------------|--|----------------|--|
| D/A Clock control | D/A clock start select                       | 1D4h<br>0x0410 | 0x0 = Software Pacer Start <br>(RD_LAS0 + 028h)<br>0x1 = External trigger<br>0x2 = Digital interrupt<br>0x3 = User TC 2 out<br>0x4 = SyncBus 0<br>0x5 = SyncBus 1<br>0x6 = SyncBus 2<br>0x7 = Software D/A clock start<br>(RD_LAS0 + 00Ch)  |
|                   | D/A clock stop select                        | 1D8h<br>0x0411 | 0x0 = Software Pacer Stop <br>(WR_LAS0 + 028h)<br>0x1 = External Trigger<br>0x2 = Digital Interrupt<br>0x3 = User TC2 out<br>0x4 = SyncBus 0<br>0x5 = SyncBus 1<br>0x6 = SyncBus 2<br>0x7 = Software D/A clock stop<br>(WR_LAS0 + 00Ch)<br>0x8 = D/A1 update counter<br>0x9 = D/A2 update counter |
|                   | D/A clock free-run or start-stop mode select | 1E8h<br>0x0412 | 0x0 = D/A clock is running free <br>0x1 = D/A clock started or stopped by functions 0x0410 or 0x0411  |

Table 4.2.1.f











| Function group          | Function name                        | LAS0 Offset Address / Function code (hex) | Function argument  |
|-------------------------|--------------------------------------|---|--|
| Timer / Counter Control | A/D Sample Counter Source Select     | 178h<br>0x0500                            | 0x0 = Reset Channel Gain Table <br>0x1 = A/D FIFO write   |
|                         | Pacer Clock Primary frequency Select | 1DCh<br>0x0501                            | 0x0 = 8MHz <br>0x1 = 20MHz  |
|                         | Burst Clock Primary frequency Select | 1E0h<br>0x0502                            | 0x0 = 8MHz <br>0x1 = 20MHz  |
|                         | DAC Clock Primary frequency Select   | 1E4h<br>0x0503                            | 0x0 = 8MHz <br>0x1 = 20MHz  |
|                         | Pacer Clock Select                   | 180h<br>0x0509                            | 0x0 = External Pacer Clock <br>0x1 = Internal Pacer Clock   |
| SyncBus Setup           | SyncBus 0 Source Select              | 184h<br>0x0510                            | 0x0 = Software A/D Start <br>(WR_LAS0 + 010h)<br>0x1 = Pacer Clock<br>0x2 = Burst Clock<br>0x3 = Digital Interrupt<br>0x4 = External Trigger<br>0x5 = Software Simultaneous D/A1 and D/A2 Update<br>0x6 = D/A Clock<br>0x7 = User TC2 out           |
|                         | Enable SyncBus 0                     | 188h<br>0x0511                            | 0x0 = disable <br>0x1 = enable  |
|                         | SyncBus 1 Source Select              | 18Ch<br>0x0512                            | 0x0 = Software A/D Start <br>(WR_LAS0+ 010h)<br>0x1 = Pacer Clock<br>0x2 = Burst Clock<br>0x3 = Digital Interrupt<br>0x4 = External Trigger<br>0x5 = Software Simultaneous D/A1 and D/A2 Update<br>0x6 = D/A Clock<br>0x7 = User TC2 out          |
|                         | Enable SyncBus 1                     | 190h<br>0x0513                            | 0x0 = disable <br>0x1 = enable  |
|                         | SyncBus 2 Select                     | 198h<br>0x0518                            | 0x0 = Software A/D Start <br>(WR_LAS0+ 010h)<br>0x1 = Software Pacer Start<br>0x2 = Software Pacer Stop<br>0x3 = Software D/A1 Update<br>0x4 = Software D/A2 Update<br>0x5 = External Pacer Clock<br>0x6 = External Trigger<br>0x7 = User TC2 out |
|                         | Enable SyncBus 2                     | 19Ch<br>0x0519                            | 0x0 = disable <br>0x1 = enable  |

Table 4.2.1.g



|   |                                    |                |  |
|---|------------------------------------|----------------|--|
| External Trigger and External Interrupt Configuration | External Trigger polarity select   | 1A4h<br>0x0601 | 0x0 = positive edge <br>0x1 = negative edge |
|   | External Interrupt polarity select | 1A8h<br>0x0602 | 0x0 = positive edge <br>0x1 = negative edge |

Table 4.2.1.h

| Function group             | Function name                     | LAS0 Offset Address / Function code (hex) | Function argument   |
|----------------------------|-----------------------------------|---|---|
| User Timer-Counter Control | User Timer/Counter 0 Clock Select | 1ACh<br>0x0700                            | 0x0 = 8MHz <sup>Ⓓ</sup><br>0x1 = Ext. TC Clock 1<br>0x2 = Ext. TC Clock 2<br>0x3 = Ext. Pacer Clock   |
|                            | User Timer/Counter 0 Gate Select  | 1B0h<br>0x0701                            | 0x0 = Not gated <sup>Ⓓ</sup><br>0x1 = Gated<br>0x2 = Ext. TC Gate 1<br>0x3 = Ext. TC Gate 2   |
|                            | User Timer/Counter 1 Clock Select | 1B4h<br>0x0702                            | 0x0 = 8MHz <sup>Ⓓ</sup><br>0x1 = Ext. TC Clock 1<br>0x2 = Ext. TC Clock 2<br>0x3 = Ext. Pacer Clock<br>0x4 = User Timer/Counter 0 out<br>0x5 = High-Speed Digital Input Sampling signal |
|                            | User Timer/Counter 1 Gate Select  | 1B8h<br>0x0703                            | 0x0 = Not gated <sup>Ⓓ</sup><br>0x1 = Gated<br>0x2 = Ext. TC Gate 1<br>0x3 = Ext. TC Gate 2<br>0x4 = User Timer/Counter 0 out   |
|                            | User Timer/Counter 2 Clock Select | 1BCh<br>0x0704                            | 0x0 = 8MHz <sup>Ⓓ</sup><br>0x1 = Ext. TC Clock 1<br>0x2 = Ext. TC Clock 2<br>0x3 = Ext. Pacer Clock<br>0x4 = User Timer/Counter 1 out   |
|                            | User Timer/Counter 2 Gate Select  | 1C0h<br>0x0705                            | 0x0 = Not gated <sup>Ⓓ</sup><br>0x1 = Gated<br>0x2 = Ext. TC Gate 1<br>0x3 = Ext. TC Gate 2<br>0x4 = User Timer/Counter 1 out   |
| User Output Signal Control | User Output Signal 0 select       | 1C4h<br>0x070E                            | 0x0 = A/D Conversion Signal <sup>Ⓓ</sup><br>0x1 = D/A1 Update<br>0x2 = D/A2 Update<br>0x3 = Software Programmable by WR_LAS0 + 008h   |
|                            | User Output Signal 1 select       | 1C8h<br>0x070F                            | 0x0 = A/D Conversion Signal <sup>Ⓓ</sup><br>0x1 = D/A1 Update<br>0x2 = D/A2 Update<br>0x3 = Software Programmable by WR_LAS0 + 008h   |

Table 4.2.1.i



| Function group                 | Function name                              | LAS0<br>Offset<br>Address /<br>Function<br>code (hex) | Function argument   |
|--------------------------------|--|---|---|
| McBSP control<br>(DM7540 only) | DM7540 A/D FIFO<br>data to DSP enable      | 1E8h<br>0x0800  | 0x0 = A/D FIFO data to DSP is disabled <br>0x1 = A/D FIFO data to DSP is enabled                         |
|                                | DM7540 D/A FIFO<br>data from DSP<br>enable | 1ECh<br>0x0801  | 0x0 = D/A1 and D/A2 FIFO data from DSP is disabled <br>0x1 = D/A1 and D/A2 FIFO data from DSP is enabled |

Table 4.2.1.j

#### 4.2.1. Software Reset of the board - LAS0 + 100h (WriteOnly)

Writing a dummy value to this address means a Software Reset.

Software Reset of the board resets all inside logic variables of the board, equivalently with the power-up states. (☞).

#### 4.2.2. DMA0 Request Source Select - LAS0 + 104h (WriteOnly)

The DMA0 Request Source Signal can be selected by writing these values to LAS0+104h:

```
0x00 = Request disable ☞
0x01 = A/D Sample Counter*
0x02 = D/A1 Sample Counter*
0x03 = D/A2 Sample Counter*
0x04 = User TC 1*
0x08 = A/D FIFO half full
0x09 = D/A1 FIFO half Empty
0x0A = D/A2 FIFO half Empty
```

The selected source controls the DMA request signal of the PCI9080 chip (DREQ0). The signals signed by \* set a request flip-flop only. These setups need the Reset DMA0 Request Machine command.

The FIFO flags control the DMA request signal directly, so they do not need the Reset command.

#### 4.2.3. DMA1 Request Source Select - LAS0 + 108h (WriteOnly)

The DMA1 Request Source Signal can be selected by writing these values to LAS0+108h:

```
0x00 = Request disable ☞
0x01 = A/D Sample Counter*
0x02 = D/A1 Sample Counter*
0x03 = D/A2 Sample Counter*
0x04 = User TC 1*
0x08 = A/D FIFO half full
0x09 = D/A1 FIFO half Empty
0x0A = D/A2 FIFO half Empty
```

The selected source controls the DMA request signal of the PCI9080 chip (DREQ1). The signals signed by \* set a request flip-flop only. These setups need the Reset DMA1 Request Machine command.

The FIFO flags control the DMA request signal directly, so they do not need the Reset command.

#### 4.2.4. Reset DMA0 Request machine - LAS0 + 1CCh (WriteOnly)

The *Reset DMA0 Request machine* command resets the DMA0 Request to the PCI9080 PCI interface chip. This command can be activated by writing to LAS0+1CCh a dummy value. This command has effect only in Demand Mode of the PCI9080. It is needed only with DMA request sources signed by \* in 4.2.2.

#### 4.2.5. Reset DMA1 Request machine - LAS0 + 1D0h (WriteOnly)

The *Reset DMA0 Request machine* command resets the DMA0 Request to the PCI9080 PCI interface chip. This command can be activated by writing to LAS0+1D0h a dummy value. This command has effect only in Demand Mode of the PCI9080. It is needed only with DMA request sources signed by \* in 4.2.3.

#### 4.2.6. A/D Conversion Signal Select - LAS0 + 10Ch (WriteOnly)

The A/D conversion Signal can be selected by writing these values to LAS0+108h:

```
0x0 = Software A/D Start (Write_LAS0+010h)
0x1 = Pacer Clock (Ext. or Int.)
0x2 = Burst Clock
0x3 = Digital Interrupt
0x4 = D/A1 Data Marker 1
0x5 = D/A2 Data Marker 1
0x6 = SyncBus0
0x7 = SyncBus1
0x8 = SyncBus2
```

The A/D Conversion signal select Function is used to choose the A/D Sampling signal:

- 0x0 means that conversions are controlled by writing dummy data to LAS0+10h
- 0x1 means that conversions are controlled by the internal or an external pacer clock.
- 0x2 means that conversions are controlled by the burst clock.
- 0x3 means that conversions are controlled by the Digital I/O chip digital interrupt output
- 0x4 means that conversions are controlled by the D/A 1 digital output data marker 1 which is updated simultaneously with the analog output 1. The conversion is started at the rising edge of data marker. It means, that this data marker must be held in low state until you want to start a conversion. After the conversion this data marker must be cleared.
- 0x5 means that conversions are controlled by the D/A 2 digital output data marker 1 which is updated simultaneously with the analog output 2. The conversion is started at the rising edge of data marker. It means, that this data marker must be held in low state until you want to start a conversion. After the conversion this data marker must be cleared.
- 0x6.. 8 means that conversions are controlled by one of the 3-line SyncBus signals.

#### 4.2.7. A/D Burst Clock start trigger select - LAS0 + 110h (WriteOnly)

If you want to use the burst clock as conversion signal source the start trigger must be set by writing this address. The stop trigger of the burst clock is generated automatically, because the stop signal basically is the CGT reset signal that occurs at the end of the whole CGT cycle.

```
0x0 = Software A/D Start (WR_LAS0+010h)
0x1 = Pacer Clock
0x2 = External Trigger
0x3 = Digital Interrupt
0x4 = SyncBus 0
0x5 = SyncBus 1
0x6 = SyncBus 2
```

- 0x0 means that burst clock will be started after writing dummy data to LAS0+010h
- 0x1 means that burst clock will be started by the internal or an external pacer clock
- 0x2 means that burst clock will be started by the External Trigger Input
- 0x3 means that burst clock will be started by the Digital I/O chip digital interrupt output
- 0x4.. 6 means that burst clock will be started by one of the 3-line SyncBus signals.

#### 4.2.8. Pacer Clock start trigger select - LAS0 + 114h (WriteOnly)

If you want to use the Pacer Clock you must specify the start and stop conditions. The Pacer Clock Start Trigger Function selects the start signal of the Pacer Clock:

```

0x0 = Software Pacer Start  E (RD_LAS0+14h)
0x1 = External trigger
0x2 = Digital interrupt
0x3 = User TC 2 out
0x4 = SyncBus 0
0x5 = SyncBus 1
0x6 = SyncBus 2
0x7 = Reserved
0x8 = Delayed Software Pacer Start
0x9 = Delayed external trigger
0xA = Delayed digital interrupt
0xB = Delayed User TC 2 out
0xC = Delayed SyncBus 0
0xD = Delayed SyncBus 1
0xE = Delayed SyncBus 2
0xF = External Trigger Gated controlled

```

- 0x0 means that the pacer clock is started by reading a dummy data from LAS0+14h
- 0x1 means that the pacer clock is started by an External Trigger Input signal
- 0x2 means that the pacer clock is started by a digital interrupt.
- 0x3 means that the pacer clock is started when the output of User TC Counter 2 reaches 0.
- 0x4 means that the pacer clock is started by by SyncBus0
- 0x5 means that the pacer clock is started by by SyncBus1
- 0x6 means that the pacer clock is started by by SyncBus2

The following start trigger sources provide delayed triggering. When the trigger is issued, the A/D Delay Counter, counts down and conversions are started when the A/D Delay Counter reaches 0. The A/D Delay Counter counts at the pacer clock rate.

- 0x8 means that the pacer clock is started by reading a dummy data from LAS0+14h
- 0x9 means that the pacer clock is started by an External Trigger Input signal
- 0xA means that the pacer clock is started by a digital interrupt.
- 0xB means that the pacer clock is started when the output of User TC Counter 2 reaches 0.
- 0xC means that the pacer clock is started by SyncBus0
- 0xD means that the pacer clock is started by SyncBus1
- 0xE means that the pacer clock is started by SyncBus2
- 0xF means the Gate Mode: the pacer clock runs as long as the External Trigger Input line is held high or low, depending on the trigger polarity. This mode does not use a stop trigger.

#### 4.2.9. Pacer Clock Stop Trigger select - LAS0 + 118h (WriteOnly)

The Pacer Clock Stop Trigger Function selects the stop signal of the Pacer Clock:

```

0x0 = Software Pacer Stop E (WR_LAS0+14h)
0x1 = External Trigger
0x2 = Digital Interrupt
0x3 = About Counter
0x4 = User TC2 out
0x5 = SyncBus 0
0x6 = SyncBus 1
0x7 = SyncBus 2
0x8 = About Software Pacer Stop
0x9 = About External Trigger
0xA = About Digital Interrupt

```

- 0x0 means that the pacer clock is stopped by writing a dummy data to LAS0+14h
- 0x1 means that the pacer clock is stopped by an External Trigger signal
- 0x2 means that the pacer clock is stopped by a digital interrupt
- 0x3 means that the pacer clock is stopped by the About Counter. The About Counter is clocked by the A/D converted samples writing in the A/D FIFO. This mode assures the desired number of samples can be sampled (count reaches 0)
- 0x4 means that the pacer clock is stopped by User TC2 output
- 0x5 means that the pacer clock is stopped by SyncBus0 signal
- 0x6 means that the pacer clock is stopped by SyncBus1 signal
- 0x7 means that the pacer clock is stopped by SyncBus2 signal

The following stop trigger sources provide about triggering, where data is acquired from the time the start trigger is received, and continues for a specified number of samples *after* the stop trigger is received. The number of samples taken after the stop trigger is received is set by the About Counter which is clocked by the writing signal of A/D FIFO.

- 0x8 means that the pacer clock is stopped by the delayed version (by a specified number of samples) of writing a dummy data to LAS0+14h.
- 0x9 means that the pacer clock is stopped by the delayed version (by a specified number of samples) of External Trigger signal
- 0xA means that the pacer clock is stopped by the delayed version (by a specified number of samples) of a digital interrupt
- 0xB Reserved
- 0xC means that the pacer clock is stopped by the delayed version (by a specified number of samples) of User TC2 output
- 0xD means that the pacer clock is stopped by the delayed version (by a specified number of samples) of SyncBus0 signal
- 0xE means that the pacer clock is stopped by the delayed version (by a specified number of samples) of SyncBus1 signal
- 0xF means that the pacer clock is stopped by the delayed version (by a specified number of samples) of SyncBus2 signal

#### 4.2.10. About Counter Stop Enable - LAS0 + 11Ch (WriteOnly)

If the Pacer Clock is the source of A/D Conversion signal and the Pacer Clock Stop comes from the About Counter counting the samples in the A/D FIFO you can extend the counting capability highest number than 10 bit defined 1024 samples.

Writing this address you can enable or disable the stop function:

0 = Stop enabled  
1 = Stop disabled

#### 4.2.11. Pacer Start Trigger Mode select - LAS0 + 120h (WriteOnly)

When set to single cycle, a trigger will initiate one conversion cycle and then stop, regardless of whether the trigger line is pulsed more than once; when set to repeat, a new cycle will start each time a trigger is received, and the current cycle has been completed. Triggers received while a cycle is in progress will be ignored.

Writing this address you can select single cycle or repeat mode:

0x0 = Single Cycle Mode - new cycle can be possible after a Software Pacer Start command  
0x1 = Trigger Repeat Mode - Pacer can be started by the selected Pacer Start Trigger

#### 4.2.12. Sampling Signal for High Speed Digital Input Select - LAS0 + 124h (WriteOnly)

The sampling signal of High-Speed Digital Input can be selected by writing this address. If you select the A/D conversion signal, the 8-bit digital input lines are simultaneously sampled with the analog signals.

0x0 = Software (Write LAS0+16h)  
0x1 = A/D Conversion Signal  
0x2 = User TC out  
0x3 = User TC out 1  
0x4 = User TC out 2  
0x5 = External Pacer Clock  
0x6 = External Trigger

#### 4.2.13. Clear High Speed Digital Input FIFO - LAS0 + 128h (WriteOnly)

Writing a dummy data to this address clears the 1K FIFO of High-Speed Digital Input.

#### 4.2.14. Clear A/D FIFO - LAS0 + 12Ch (WriteOnly)

Writing a dummy data to this address clears the A/D FIFO.

The Table 4.1.4. shows the *Channel Gain Table Control Functions*. The Figure 4.1.1. shows the bits of Channel Gain Latch - single-channel mode and the bits of the Channel Gain Table -multichannel mode.

### 4.2.15. Write ADC channel gain table - LAS0 + 130h (WriteOnly)

In the case of multi-channel operation the Channel Gain Table must be used. Before writing the channel gain table entries write a dummy data to LAS0+144h to clear the table.

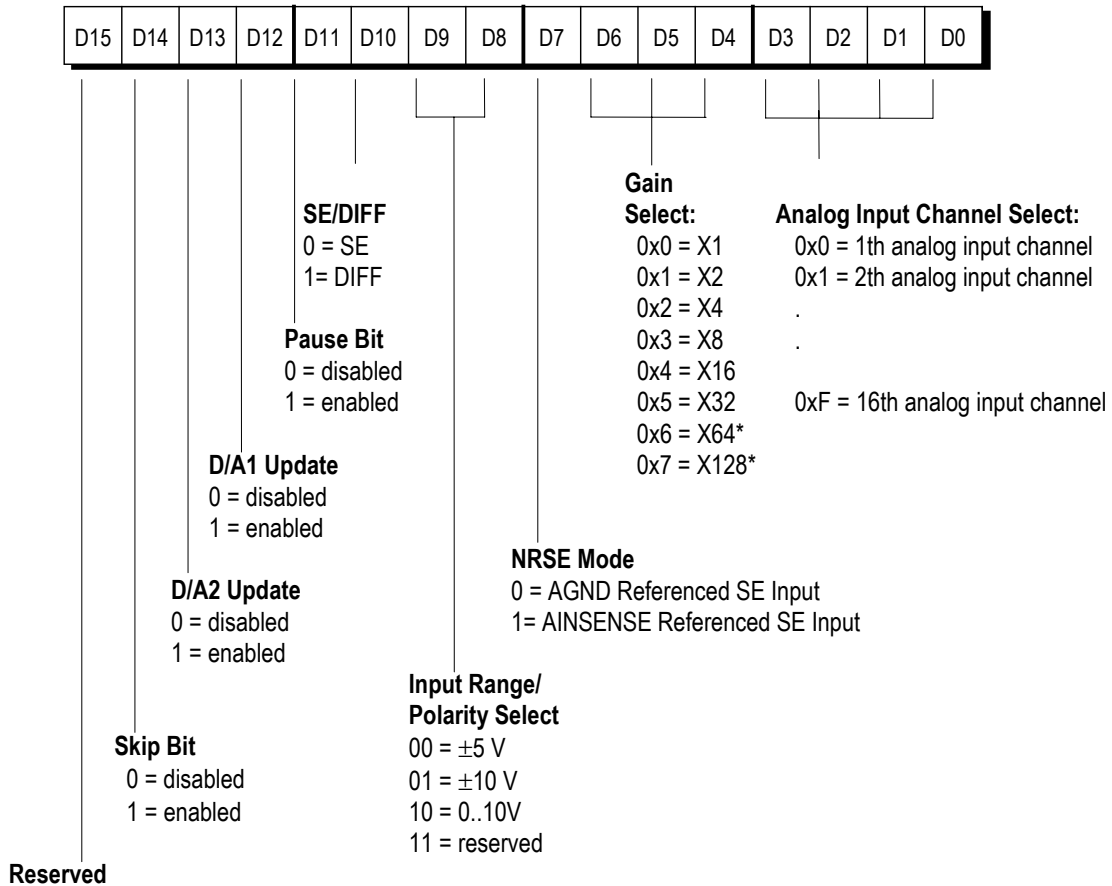

\*: The DM7520 has no 64, and 128 gain factors

Figure 4.2.1. Channel-gain select latch/ Channel-gain table entry

**Using the pause bit:** The pause bit of the channel-gain word is set to 1 if you want to stop at an entry in the table and wait for the next trigger to resume conversions. In burst mode, the pause bit is ignored.

**Using the skip bit:** The skip bit of the channel-gain word is set to 1 if you want to skip an entry in the table. This feature allows you to sample multiple channels at different rates on each channel. For example, if you want to sample channel 1 once each second and channel 4 once every 3 seconds, you can set the skip bit on channel 4. With the skip bit set on the four table entries; these entries will be ignored, and no A/D conversion will be performed. This saves memory and eliminates the need to throw away unwanted data.

### 4.2.16. Write ADC channel gain latch - LAS0 + 134h (WriteOnly)

In the case of single-channel operation the Channel Gain Latch must be used. The data structure is the same as in the Channel Gain Table but there are no meaning of the skip bit, D/Ax Update and the Pause Bit. These bits must be zero.

#### 4.2.17. Write Digital table - LAS0 + 138h (WriteOnly)

The Digital Table is part of the Channel Gain Table, and can be used to control external devices. Using this function you can fill the 8bit wide Digital Table. Reading of the Digital Table is simultaneous with reading the Channel Gain Table. Figure 4.1.2. shows the bit structure of Digital Table.

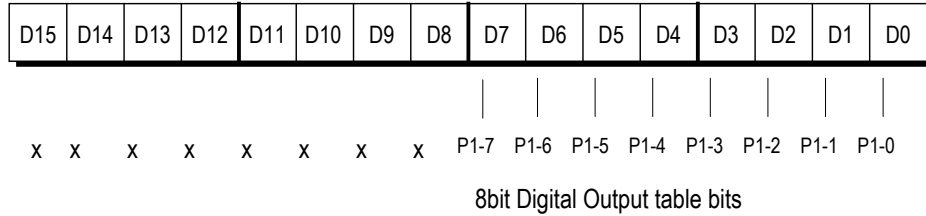

Figure 4.2.2. Digital Output Table bits

The Digital Output Table bits use the same lines as the Digital I/O Chip Port 1 I/O port. In the case of usage the P1 digital I/O lines the Digital Table bits cannot be used. The Enable Digital Table Function (0x0304) can be used to select between the Digital I/O P1 port and the Digital Output Table bits.

The digital portion of the channel-gain table provides 8 bits to control devices such as external expansion boards. For example, if you have connected one of your input channels on the PCI4520/DM7520/DM7540 to RTD's TMX32 input expansion board, you can use the bottom 5 bits in this byte to control the TMX32 board channel selection. To load digital information into this portion of the channel, use this function. This information will be output on the Port 1 lines when you run through the table. The format shown above is for controlling the TMX32's channel selection (32 single-ended or 16 differential). The first load operation will be in the first entry slot of the table (lining up with the first entry in the A/D table), and each load thereafter fills the next position in the channel-gain table. Note that when you are using the digital table, all 8 bits are used and controlled by the table, regardless of the number of bits you may actually need for your digital control application.

#### 4.2.18. Enable Channel Gain Table - LAS0 + 13Ch (WriteOnly)

Writing to this address you can select the Channel Gain Latch or the Channel Gain Table controlled operation.

```
0x0 = Channel Gain Table disabledⓈ
      Channel Gain Latch enabledⓈ
0x1 = Channel Gain Table enabled
      Channel Gain Latch disabled
```

#### 4.2.19. Enable Digital Table - LAS0 + 140h (WriteOnly)

Writing to this address you can select the P1 port of Digital I/O chip or the output of the Digital Table on the pin 32..46 of External I/O connector.

```
0x0 = Digital Table disabledⓈ
      Digital I/O P1 port enabledⓈ
0x1 = Digital Table enabled
      Digital I/O P1 port disabled
```

#### 4.2.20. Table Pause enable - LAS0 + 144h (WriteOnly)

The pause bit of the Channel Gain Table is set to 1 if you want to stop at an entry in the table and wait for the next trigger to resume conversions. In burst mode, the pause bit is ignored. Writing this address this mode can be enabled:

0x0 = Table Pause disabled  
 0x1 = Table Pause enabled

#### 4.2.21. Reset Channel Gain Table - LAS0 + 148h (WriteOnly)

Writing a dummy data to this address sets the read pointer of the Channel Gain Table to the beginning of the Table. The write pointer of the Table does not change.

#### 4.2.22. Clear Channel Gain Table - LAS0 + 14Ch (WriteOnly)

Writing a dummy data to this address sets the read *and* the write pointer of the Channel Gain Table to the beginning of the Table.

The Table 4.1.5. shows the D/A Control Function Group. This functions is used to configure the D/A output channels, DAC1 and DAC2, on the PCI4520/DM7520/DM7540 as follows:

#### 4.2.23. D/A1 output type / range - LAS0 + 150h (WriteOnly)

Writing this address sets the voltage output range and polarity for DAC1:

0x0 = unipolar 0..5V  
 0x1 = unipolar 0.. 10V  
 0x2 = bipolar  $\pm 5V$   
 0x3 = bipolar  $\pm 10V$

#### 4.2.24. D/A1 update source - LAS0 + 154h (WriteOnly)

Writing this address selects the update source for D/A 1.

0x0 = Software D/A1 Update  
 0x1 = CGT controlled D/A1 Update  
 0x2 = D/A Clock  
 0x3 = External pacer clock  
 0x4 = SyncBus 0  
 0x5 = SyncBus 1  
 0x6 = SyncBus 2

Software uses the Software D/A1 Update command (Write a dummy data to LAS0 + 014h) to update the DAC1 output; the CGT Controlled Update assures simultaneous D/A update with the A/D conversion; D/A Clock is the output of the D/A clock counter, External Pacer Clock is a signal at the External I/O connector., SyncBus0.. 2 can update source also.

#### 4.2.25. D/A1 Cycle Mode - LAS0 + 158h (WriteOnly)

This bits enables the cycle mode for the D/A converters. By setting these bits to a 1, the D/A1 will continuously repeat the data that is stored in the D/A1 FIFO. This is useful for waveform generation.

0x0 = not cycle  
 0x1 = cycle

#### 4.2.26. Reset D/A1 FIFO - LAS0 + 15Ch (WriteOnly)

Writing a dummy data to this address sets the read pointer of the D/A1 FIFO to the beginning of the FIFO. The write pointer of the FIFO does not change.

**4.2.27. Clear D/A1 FIFO - LAS0 + 160h (WriteOnly)**

Writing a dummy data to this address sets the read *and* the write pointer of the D/1 FIFO to the beginning of the FIFO.

**4.2.28. D/A2 output type / range - LAS0 + 164h (WriteOnly)**

Writing this address sets the voltage output range and polarity for DAC1:

```
0x0 = unipolar 0..5VE
0x1 = unipolar 0.. 10V
0x2 = bipolar ±5V
0x3 = bipolar ±10V
```

**4.2.29. D/A2 update source - LAS0 + 168h (WriteOnly)**

Writing this address selects the update source for D/A 1.

```
0x0 = Software D/A2 Update
0x1 = CGT controlled D/A2 Update
0x2 = D/A Clock
0x3 = External Pacer Clock
0x4 = SyncBus 0
0x5 = SyncBus 1
0x6 = SyncBus 2
```

Software uses the Software D/A1 Update command (Write a dummy data to LAS0 + 018h) to update the DAC1 output; the CGT Controlled Update assures simultaneous D/A update with the A/D conversion; D/A Clock is the output of a 16 bit wide internal counter, External Pacer Clock is a signal at the External I/O connector., SyncBus0.. 2 can update source also.

**4.2.30. D/A2 Cycle Mode - LAS0 + 16Ch (WriteOnly)**

This bit enables the cycle mode for the D/A2 converter. By setting these bits to a 1, the D/A will continuously repeat the data that is stored in the D/A FIFO. This is useful for waveform generation.

```
0x0 = not cycle
0x1 = cycle
```

**4.2.31. Reset D/A2 FIFO - LAS0 + 170h (WriteOnly)**

Writing a dummy data to this address sets the read pointer of the D/A2 FIFO to the beginning of the FIFO. The write pointer of the FIFO does not change.

**4.2.32. Clear D/A2 FIFO - LAS0 + 174h (WriteOnly)**

Writing a dummy data to this address sets the read *and* the write pointer of the D/A2 FIFO to the beginning of the FIFO.

The following section shows the *Timer/Counter Control Function Group*.

#### 4.2.33. A/D Sample Counter Source Select - LAS0 + 178h (WriteOnly)

Writing this address the A/D Sample Counter Clock can be selected:

0x0 = Reset Channel Gain Table   
 0x1 = A/D FIFO write

If you want to count all of the sampled analog data select the A/D FIFO write argument. If you want to count the CGT periods select the Reset Channel Gain Table argument.

#### 4.2.34. Pacer Clock Select - LAS0 + 180h (WriteOnly)

Selects the internal Pacer Clock, which is the output of internal Pacer Clock generator or an external Pacer Clock routed onto the board through External I/O connector:

0x0 = External Pacer Clock   
 0x1 = Internal Pacer Clock

The maximum Pacer Clock rate supported by the board is 1.25 MHz.

The following section shows the *SyncBus Setup Function Group*.

#### 4.2.35. SyncBus 0 Source Select - LAS0 + 184h (WriteOnly)

This function selects the source of the SyncBus 0 signal:

0x0 = Software A/D Start   
 0x1 = Pacer Clock  
 0x2 = Burst Clock  
 0x3 = Digital Interrupt  
 0x4 = External Trigger  
 0x5 = Software Simultaneous D/A1 and D/A2 Update  
 0x6 = D/A Clock  
 0x7 = User TC2 out

The SyncBus is a 3-line synchronization purpose bus to synchronize the operation of multiply PCI4520/DM7520/DM7540 or other RTD DAQ Boards (PCI4400). The source of signals can be the same and can be on the other PCI4520/DM7520/DM7540 boards.

#### 4.2.36. Enable SyncBus 0 - LAS0 + 188h (WriteOnly)

This function enables the SyncBus 0 buffer (see Figure 4.1.6.)

0x0 = disable   
 0x1 = enable

Important, that one SyncBus signal may have only *one* enabled active buffer.

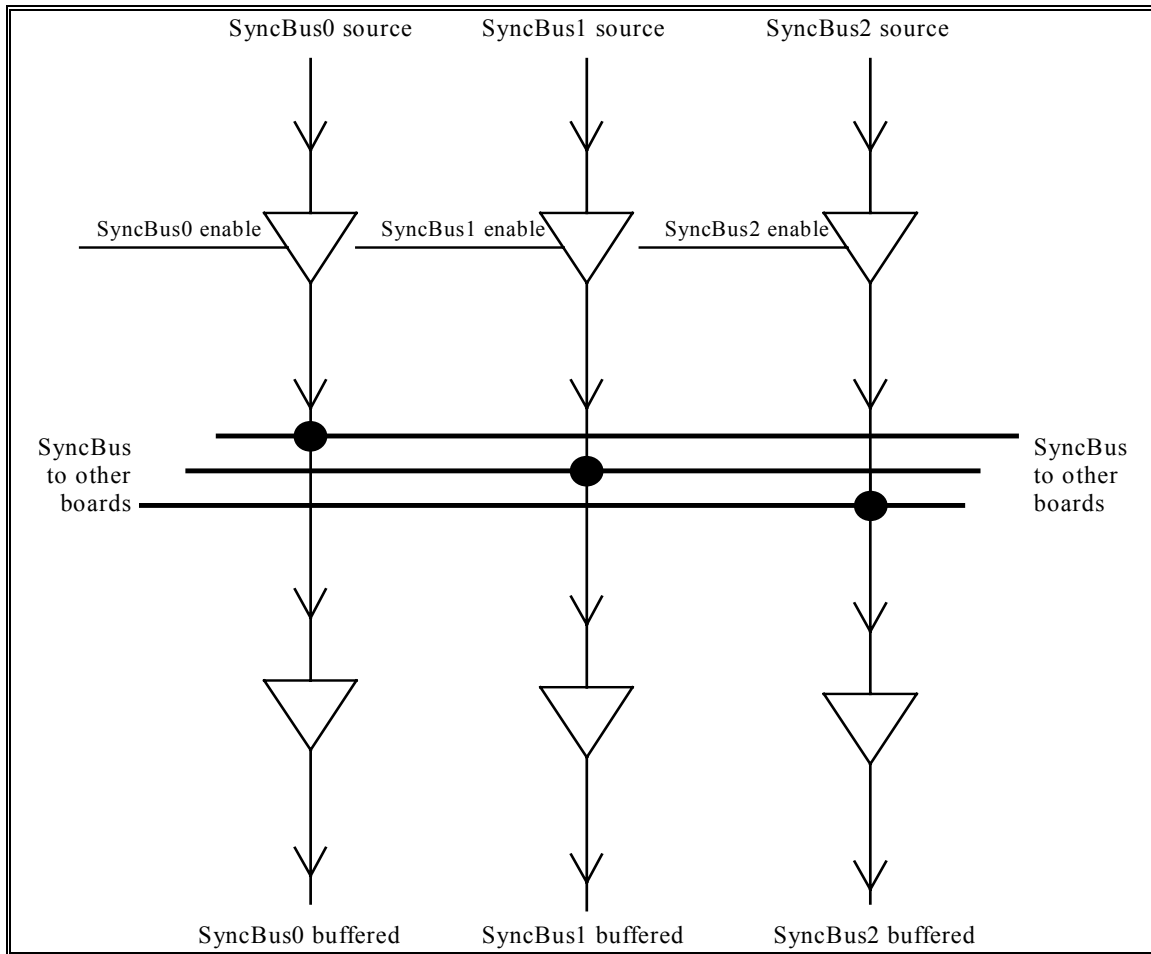

Figure 4.2.3. The SyncBus structure

#### 4.2.37. SyncBus 1 Source Select - LAS0 + 18Ch (WriteOnly)

This function selects the source of the SyncBus 1 signal:

```

0x0 = Software A/D Start
0x1 = Pacer Clock
0x2 = Burst Clock
0x3 = Digital Interrupt
0x4 = External Trigger
0x5 = Software Simultaneous D/A1 and D/A2 Update
0x6 = D/A Clock
0x7 = User TC2 out

```

The SyncBus is a 3-line synchronization purpose bus to synchronize the operation of multiply PCI4520/DM7520/DM7540 or other RTD DAQ Boards. The source of signals can be the same and can be on the other PCI4520/DM7520/DM7540 boards.

**4.2.38. Enable SyncBus 1 - LAS0 + 190h (WriteOnly)**

This function enables the SyncBus 1 buffer (see Figure 4.1.6.)

0x0 = disable   
 0x1 = enable

Important, that one SyncBus signal may have only *one* enabled active buffer.

**4.2.39. SyncBus 2 Source Select - LAS0 + 198h (WriteOnly)**

This function selects the source of the SyncBus 2 signal:

0x0 = Software A/D Start   
 0x1 = Software Pacer Start  
 0x2 = Software Pacer Stop  
 0x3 = Software D/A1 Update  
 0x4 = Software D/A2 Update  
 0x5 = External Pacer Clock  
 0x6 = External Trigger  
 0x7 = User TC2 out

The SyncBus is a 3-line synchronization purpose bus to synchronize the operation of multiply PCI4520/DM7520/DM7540 or other RTD DAQ Boards. The source of signals can be the same and can be on the other PCI4520/DM7520/DM7540 boards.

**4.2.40. Enable SyncBus 2 - LAS0 + 19Ch (WriteOnly)**

This function enables the SyncBus 2 buffer (see Figure 4.1.6.)

0x0 = disable   
 0x1 = enable

Important, that one SyncBus signal may have only *one* enabled active buffer.

The following section shows the *External Trigger and External Interrupt Configuration Function Group*.

**4.2.41. External Trigger polarity select - LAS0 + 1A4h (WriteOnly)**

This function selects the active polarity of External Trigger signal:

0x0 = positive edge   
 0x1 = negative edge

The External Trigger signal comes from the External I/O connector.

**4.2.42. External Interrupt polarity select - LAS0 + 1A8h (WriteOnly)**

This function selects the active polarity of External Interrupt signal:

0x0 = positive edge   
 0x1 = negative edge

The External Interrupt signal comes from the External I/O connector. The External Interrupt may be a source of built-in priority Interrupt Controller.

The following section shows the *User TC Configuration Function Group*. The User TC is a 8254 chip (U43) with three timer, which can be used by the user. The clock gate sources can be programmed by this Function Group.

#### 4.2.43. User Timer/Counter 0 Clock Select - LAS0 + 1ACh (WriteOnly)

This function selects the source of the User TC 0 clock signal:

```
0x0 = 8MHzⓈ
0x1 = Ext. TC Clock 1
0x2 = Ext. TC Clock 2
0x3 = Ext. Pacer Clock
```

The source of the clock may be the internal 8MHz clock signal, and the *External TC Clock x*, and the *External Pacer Clock* signal from the External I/O connector.

#### 4.2.44. User Timer/Counter 0 Gate Select - LAS0 + 1B0h (WriteOnly)

This function selects the source of the User TC 0 gate signal:

```
0x0 = Not gatedⓈ
0x1 = Gated
0x2 = Ext. TC Gate 1
0x3 = Ext. TC Gate 2
```

The source of the gate may be a fix logic high - not gated, free running mode or fix logic low - gated shut-down mode, and the *External TC Gate x* from the External I/O connector.

#### 4.2.45. User Timer/Counter 1 Clock Select - LAS0 + 1B4h (WriteOnly)

This function selects the source of the User TC 1 clock signal:

```
0x0 = 8MHzE
0x1 = Ext. TC Clock 1
0x2 = Ext. TC Clock 2
0x3 = Ext. Pacer Clock
0x4 = User Timer/Counter 0 out
0x5 = High-Speed Digital Input Sampling signal
```

The source of the clock may be the internal 8MHz clock signal, and the *External TC Clock x*, and the *External Pacer Clock* signal from the External I/O connector, therefore you can cascade the timer TC 0 using the *User Timer/Counter 0 Out* signal. You can use User TC 1 as a Sample Counter for the High-Speed Digital Input FIFO.

#### 4.2.46. User Timer/Counter 1 Gate Select - LAS0 + 1B8h (WriteOnly)

This function selects the source of the User TC 1 gate signal:

```
0x0 = Not gatedE
0x1 = Gated
0x2 = Ext. TC Gate 1
0x3 = Ext. TC Gate 2
0x4 = User Timer/Counter 0 out
```

The source of the gate may be a fix logic high - not gated, free running mode or fix logic low - gated shut-down mode, and the *External TC Gate x* from the External I/O connector. You can gate the user TC1 by the output of the User TC 0

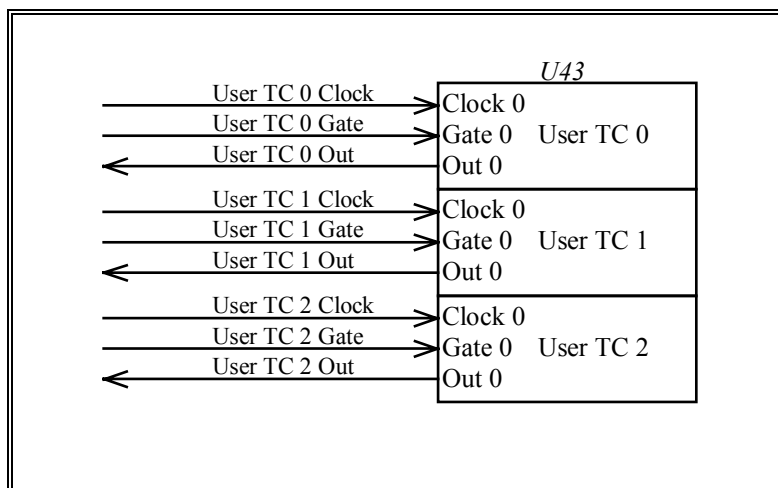

Figure 4.2.4. User TC section

#### 4.2.47. User Timer/Counter 2 Clock Select - LAS0 + 1BCh (WriteOnly)

This function selects the source of the User TC 2 clock signal:

```
0x0 = 8MHz
0x1 = Ext. TC Clock 1
0x2 = Ext. TC Clock 2
0x3 = Ext. Pacer Clock
0x4 = User Timer/Counter 1 out
```

The source of the clock may be the internal 8MHz clock signal, and the *External TC Clock x*, and the *External Pacer Clock* signal from the External I/O connector, therefore you can cascade the timer TC 1 using the *User Timer/Counter 1out* signal. You can use User TC 1 as a Sample Counter for the Hig-Speed Digital Input FIFO.

#### 4.2.48. User Timer/Counter 2 Gate Select - LAS0 + 1C0h (WriteOnly)

This function selects the source of the User TC 2 gate signal:

```
0x0 = Not gated
0x1 = Gated
0x2 = Ext. TC Gate 1
0x3 = Ext. TC Gate 2
0x4 = User Timer/Counter 1 out
```

The source of the gate may be a fix logic high - not gated, free running mode or fix logic low - gated shut-down mode, and the *External TC Gate x* from the External I/O connector. You can gate the user TC 2 by the output of the User TC 1

The following section shows the *User Output Configuration Function Group*.

#### 4.2.49. User Output 0 Signal Select - LAS0 + 1C4h (WriteOnly)

The source of the *User Out 0* can be programmed this function:

```
0x0 = A/D Conversion Signal
0x1 = D/A1 Update
0x2 = D/A2 Update
0x3 = Software Programmable by LAS 0+8h
```

The selected sources are buffered and connected to the External I/O connector. In the case of software source the User Output lines can be programmed by writing the LAS 0 +8h address. (User Input lines which come from the External I/O connector can be read by reading the LAS 0+8h address.)

#### 4.2.50. User Output 1 Signal Select - LAS0 + 1C8h (WriteOnly)

The source of the *User Out 0* can be programmed this function:

```
0x0 = A/D Conversion Signal
0x1 = D/A1 Update
0x2 = D/A2 Update
0x3 = Software Programmable by LAS 0+8h
```

The selected sources are buffered and connected to the External I/O connector. In the case of software source the User Output lines can be programmed by writing the LAS 0 +8h address. (User Input lines which come from the External I/O connector can be read by reading the LAS 0+8h address.)

#### 4.2.51. McBSP A/D FIFO control - LAS0 + 1E8h (WriteOnly)

This Function enables the automatic A/D FIFO data sending to the connected DSP via the McBSP serial connection:

```
0x0 = A/D FIFO data to DSP is disabled
0x1 = A/D FIFO data to DSP is enabled
```

If this Function is enabled, the new A/D data in the A/D FIFO will be read and sent automatically to the DSP via the serial port. This means that this data cannot be read by the host (or other PCI master) via the PCI bus.

#### 4.2.52. McBSP D/A1 and D/A2 FIFO control - LAS0 + 1ECh (WriteOnly)

This Function enables to the connected DSP to write the D/A1 and D/A2 FIFO via the McBSP serial connection:

```
0x0 = D/A1 and D/A2 FIFO data from DSP is disabled
0x1 = D/A1 and D/A2 FIFO data from DSP is enabled
```

If this Function is enabled, the sent data from the DSP via the serial connection will be automatically written to the appropriate D/A FIFO.

### 4.3. Local Address Space 1 (LAS1)

This is a 16bit wide memory mapped address space. It can be accessed by word wide (16 bit) single cycle, or double word-wide (32bit) DMA controlled Burst mode read/write instructions.

The range size is 16 byte.

This address space is used to transfer data from A/D input FIFO, High Speed Digital Input FIFO, and to the D/A output FIFOs.

You can use 16 bit wide (word) or 32 bit wide (Lword) direct slave read/write instructions. In the case of Lword instruction two word long burst cycle is generated by the CPU. If you use the onboard DMA controller you can use long burst cycles that assures fast data transfer between the board and the CPU.

| Read Function                      | Write Function  | Local Address Space 1 Offset hexa | Local bus Address hexa |
|------------------------------------|-----------------|-----------------------------------|------------------------|
| Read A/D FIFO                      | -               | 0h<br>(16-bit)                    | 40000000h              |
| Read High Speed Digital Input FIFO | -               | 4h<br>(16-bit)                    | 40000004h              |
| -                                  | Write D/A1 FIFO | 8h<br>(16-bit)                    | 40000008h              |
| -                                  | Write D/A2 FIFO | Ch<br>(16-bit)                    | 4000000Ch              |

Table 4.3.1.

#### 4.3.1. Local Address Space 1 +0h: Read A/D FIFO (Read only)

A read provides the 12-bit A/D converted data as shown below. Bit 15 is the sign bit extension. This sign bit extension gives the opportunity to read the converted data as two's complement number in either unipolar or bipolar mode.

The bottom three bits are the samples of the buffered version of the External I/O connector Port 0 Digital I/O port P0-5, P0-6, P0-7 lines. The sampling is simultaneous with this read instruction.

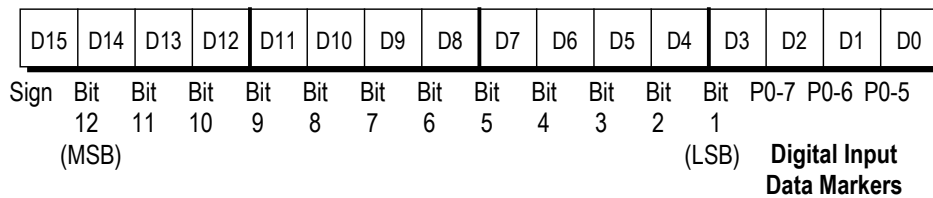

Figure 4.3.1.

#### 4.3.2. Local Address Space 1 +4h: Read High Speed Digital Input FIFO (Read only)

A read provides the 8-bit High Speed Digital Input Data bits which are programmable source sampled. The High Speed Digital Input lines are commonly used with the Digital I/O , bitprogrammable P0 port. The upper byte is undefined.

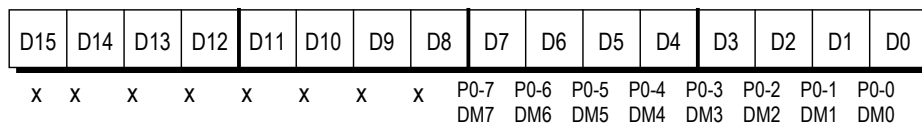

Figure 4.3.2.



## 5. A/D Conversion

This chapter shows you how to program your PCI4520/DM7520/DM7540 to perform A/D conversions and read the results. Included in this discussion are instructions on setting up the Channel Gain Table (CGT), the on-board clocks and sample counter, and various conversion and triggering modes. The following paragraphs walk you through the programming steps for performing A/D conversions. Detailed information about the conversion modes and triggering is presented in this section. You can follow these steps in the example programs included with the board.

### 5.1. Before Starting Conversions: Initializing the Board

Regardless of the conversion mode you wish to set up, you should always start your program with a board initialization sequence. This sequence should include:

- Clear Board command
- Clear IRQ command
- Clear Channel Gain Table command
- Clear A/D FIFO command
- Clear D/A FIFOs commands
- Clear Digital I/O chip

This initialization procedure clears all board registers, empties the Channel Gain Table, resets the digital I/O chip and empties the A/D and D/A FIFOs.

#### 5.1.1. Before Starting Conversions (single-channel mode): Programming Channel, Gain, Input Range and Type using Channel Gain Latch (CGL)

Setting up these things can be done using the Channel Gain Latch (single-channel mode) or using the Channel Gain Table (multi-channel mode) The CGL can be filled up by Function 0x301. The Channel Gain Latch has very similar structure to the Channel Gain Table, so all operation are explained in the next sections of CGT.

#### 5.1.2. Before Starting Conversions (multi-channel mode): Programming the Channel-Gain Table (CGT)

The Channel Gain Table can be programmed with 1024 24-bit entries in tabular format. Sixteen bits contain the A/D channel-gain data (A/D Table), and 8 bits contain digital control data (Digital Table) to support complex channel-gain sequences. To load a new Channel Gain Table, first clear the Channel Gain Table by Function 0x030F (see Table 4.1.4.). To add entries to an existing table, simply write to the A/D Table (and Digital Table if used) as described in the following paragraphs. Note that writing beyond the end of the table is ignored.

#### 5.1.3. 16-Bit A/D Table

The A/D portion of the Channel Gain Table with the channel, gain, input range, input type, pause and skip bit information is programmed into the channel-gain scan memory using the Function 0x300. If you have cleared the existing table, the first word written will be placed in the first entry of the table, the second word

will be placed in the second entry, and so on. If you are adding to an existing table, the new data written will be added at the end.

### 5.1.4. Channel Select, Gain Select, Input Range and Input Type

The channel number, gain value, input range and input type are entered in the table using bits 0 through 10. Each of these parameters can be set independently for every entry in the table. This allows you to set up a complex array of sampling sequences mixing channels, gains, input ranges and input types. Care must be taken in selecting the proper input type. The board is capable of 16 single-ended inputs or 8 differential inputs. You can select combinations of single-ended and differential but each differential channel actually uses 2 single-ended channels. If you select channel 1 to be a differential channel, you must connect your signal to AIN1+ and AIN1-. Channel 8 now is not available as a single-ended channel. In the case of single ended mode you can choose the Ground Referenced Single Ended (GRSE mode) or the Non Referenced Single Ended Mode (NRSE). See Chapter 2.

### 5.1.5. Pause bit

Bit 11 is used as a pause bit. If this bit is set to a "1" and the Pause function is enabled by Function 0x0305, the A/D conversions will stop at this entry in the table and resume on the next Start Trigger. This is useful if you have 2 different sequences loaded in the table. You can enable and disable this bit's function by Function 0x305. In the case of single channel mode, when the CGL is used this function is meaningless. NOTE: This bit is ignored in the Burst sampling modes.

### 5.1.6. D/Ax update bits

Bit 12, 13 is used for simultaneous update the D/Ax converter with the sampling of the appropriate analog input channel. When these bits are in high state a D/A update signal is generated at the sampling time of the analog input.

### 5.1.7. Skip bit

If bit 14 of the data loaded is set to 1, then the skip bit is enabled and this entry in the channel-gain table will be skipped, meaning an A/D conversion will be performed but the data is not written into the A/D FIFO. This feature provides an easy way to sample multiple channels at different rates without saving unwanted data. A simple example illustrates this bit's function.

In this example, we want to sample channel 1 once each second and channel 4 once every three seconds. First, we must program 6 entries into the channel-gain table. The channel 4 entries with the skip bit set will be skipped when A/D conversions are performed. The table will continue to cycle until a stop trigger is received.

Next, we will set the pacer clock to run at 2 Hz (0.5 seconds). This allows us to sample each channel once per second, the maximum sampling rate required by one of the channels (pacer clock rate = number of different channels sampled x fastest sample rate). The first clock pulse starts an A/D conversion according to the parameters set in the first entry of the channel-gain table, and each successive clock pulse incrementally steps through the table entries. As shown in Figure 5-1 and Figure 5-2, the first clock pulse starts a sample on channel 1. The next pulse looks at the second entry in the channel-gain table and sees that the skip bit is set to 1. No A/D data is stored. The third pulse starts a sample on channel 1 again, the fourth pulse skips the next entry, and the fifth pulse takes our third reading on channel 1. On the sixth pulse, the skip bit is disabled and channel 4 is sampled. Then the sequence starts over again. Samples are not stored when they are not wanted, saving memory and eliminating the need to throw away unwanted data.

### 5.1.8. 8-Bit Digital Table

The digital portion of the channel-gain table can be programmed with digital control information using the Write Digital Table Function 0x0302. If you have cleared the existing table by the CGT clear Function 0x030F, the first byte written will be placed in the first entry of the table, the second byte will be placed in the second entry, and so on. If you are adding to an existing table, the new data written will be added at the end. The first entry made into the Digital Table lines up with the first entry made into the A/D Table, the second entry made into the Digital Table lines up with the second entry made into the A/D Table, and so on. Make sure that, if you add to an existing table and did not program the Digital Table portion when you made your A/D Table entries previously, you fill those entries with digital data first before entering the desired added data. Since the first digital entry you make always lines up with the first A/D entry made, failure to do this will cause the A/D and digital control data to be misaligned in the table. You cannot turn the digital control lines off for part of a conversion sequence and then turn them on for the remainder of the sequence. Note that the digital data programmed here is sent out on the Port 1 digital I/O lines whenever this portion of the table is enabled by the Function 0x0304.

These lines can be used to control input expansion boards such as the TMX32 analog input expansion board at the same speed as the A/D conversions are performed with no software overhead.

NOTE: If you only need to use the A/D part of the table, you do not have to program the Digital Table. However if you only want to use the Digital part of the table you must program the A/D part of the table.

### 5.1.9. Setting Up A/D part and Digital part of Channel Gain Table

Let's look at how the Channel Gain Table is set up for a simple example using both the A/D and Digital Tables. In this example, we have a TMX32 expansion board connected to channel 1 on the PCI4520/DM7520. Load the channel-gain sequence into the A/D Table (Function 0x0300):

```
Entry 1      0000 0000 0000 0000 gain = 1, channel number = 1
Entry 2      0000 0000 0010 0000 gain = 4, channel number = 1
Entry 3      0100 0000 0000 0000 skip sample
Entry 4      0000 0000 0010 0000 gain = 4, channel number = 1
Entry 5      0000 0000 0000 0000 gain = 1, channel number = 1
Entry 6      0000 0000 0010 0000 gain = 4, channel number = 1
```

Load the digital data into the Digital Table by Function 0x0302. The first digital word loaded lines up with the first A/D Table entry, and so on:

```
Entry 1 0000 0000 0000 0000 gain=1 PCI4520/DM7520/DM7540 channel=1 0000 0000 TMX32
channel=1
Entry 2 0000 0000 0010 0000 gain=4 PCI4520/DM7520/DM7540 channel=1 0000 0011 TMX32
channel=4
Entry 3 0000 1000 0000 0000 skip sample 0000 0000 TMX32 channel=1 (skip)
Entry 4 0000 0000 0010 0000 gain=4 PCI4520/DM7520/DM7540 channel=1 0000 0011 TMX32
channel=4
Entry 5 0000 0000 0000 0000 gain=1 PCI4520/DM7520/DM7540 channel=1 0000 0000 TMX32
channel=1
Entry 6 0000 0000 0010 0000 gain=4 PCI4520/DM7520/DM7540 channel=1 0000 0011 TMX32
channel=4
```

### 5.1.10. Using the Channel Gain Table for A/D Conversions

After the Channel Gain Table is programmed, it must be enabled in order to be used for A/D conversions by Function 0x0303. The Digital Table can be enabled by Function 0x0304 when the digital control data is stored. You cannot use the Digital Table without enabling the Channel Gain Table. When the Digital Table is enabled, the 8-bit data is sent out on the Port 1 digital I/O lines.

When you are using the channel-gain table to take samples, it is strongly recommended that you do not enable, disable, and then re-enable the table while performing a sequence of conversions. This causes skipping of an entry in the table. In this case you should issue a reset table command by Function 0x030E.

### 5.1.11. Channel-gain Table and Throughput Rates

When using the Channel Gain Table, you should group your entries to maximize the throughput of your module. Low-level input signals and varying gains are likely to drop the throughput rate because low level inputs must drive out high level input residual signals. To maximize throughput:

- Keep channels configured for a certain range grouped together, even if they are out of sequence.
- Use external signal conditioning if you are performing high speed scanning of low level signals. This increases throughput and reduces noise.
- If you have room in the channel-gain table, you can make an entry twice to make sure that sufficient settling time has been allowed and an accurate reading has been taken. Set the skip bit for the first entry so that it is ignored.
- For best results, do not use the channel-gain table when measuring steady-state signals. Use the single convert mode to step through the channels.

## 5.2. A/D Conversion Modes

To support a wide range of sampling requirements, the PCI4520/DM7520/DM7540 provides several conversion modes with a selection of trigger sources to start and stop a sequence of conversions. Understanding how these modes and sources can be configured to work together is the key to understanding the A/D conversion capabilities of your module.

The following paragraphs describe the conversion and trigger modes.

### 5.2.1. Start A/D Conversion signal

Using the Function 0x0200 one of nine modes can be selected as A/D conversion signal as can be seen on Figure 5.2.1.

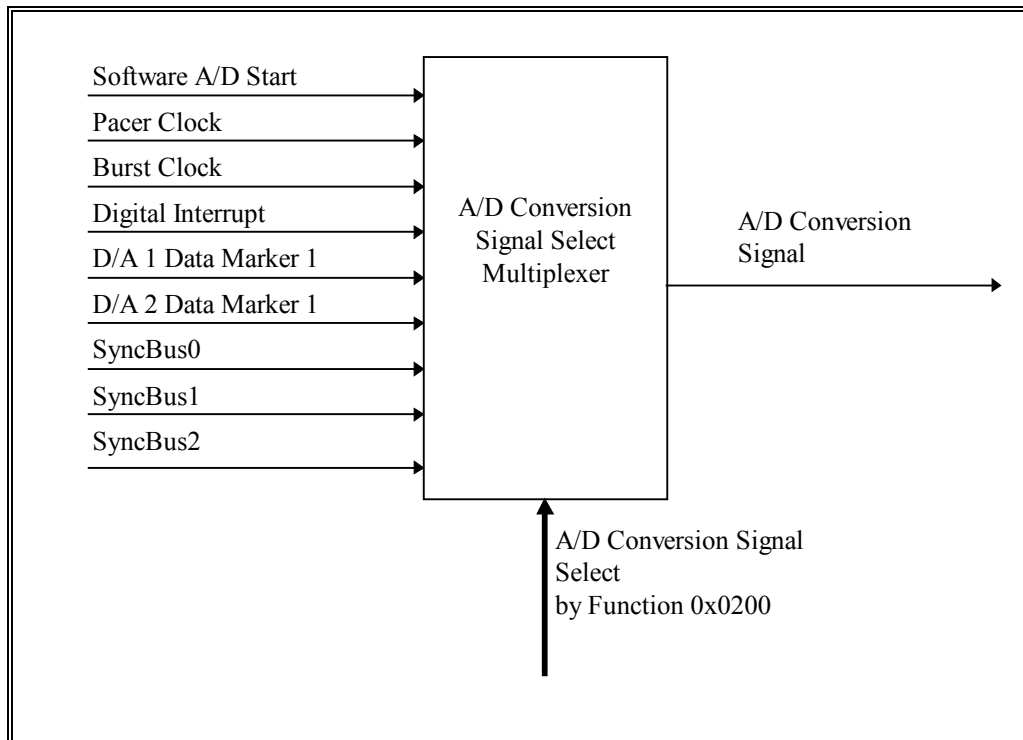

Figure 5.2.1.

- *Software A/D Start* (by writing LAS0+8h to initiate a Start Convert)
- *Pacer Clock* (internal TC - see Figure 4.1.4 -or external)
- *Burst Clock* (internal TC - see Figure 4.1.4 )
- *Digital Interrupt* generated by the Advanced Digital Interrupt circuit
- *D/A 1 Data Marker 1* for simultaneous A/D conversion with D/A update
- *D/A 2 Data Marker 1* for simultaneous A/D conversion with D/A update
- *SyncBus* signals (three lines)

### 5.2.2. Pacer Clock Start/Stop Trigger Select.

The Pacer Clock start trigger can be set by the Function 0x0202. The Pacer Clock stop trigger can be set by the Function 0x0203. This functions can be used to turn the pacer clock (internal or external) on

and off. Through these different combinations of start and stop triggers, the PCI4520/DM7520/DM7540 supports pre-trigger, post-trigger, and about-trigger modes with various trigger sources.

**The Pacer Clock start trigger sources are:**

- *Software Pacer Start* When selected, a read at LAS0+14h will start the Pacer Clock.
- *External trigger* When selected, a positive- or negative-going edge (depending on the setting of the trigger polarity, Function 0x0601) on the external TRIGGER INPUT line, will start the pacer clock. The pulse duration should be at least 100 nanoseconds.
- *Digital interrupt* When selected, a digital interrupt -generated by Advanced Digital I/O chip - will start the Pacer Clock.
- *User TC 2 out* When selected, a pulse on the User Timer/Counter 2 - see Figure 4.1.7. - output line (Counter 2's count reaches 0) will start the pacer clock.
- *SyncBus 0* When selected a positive edge on the SyncBus 0 line will start the pacer clock.
- *SyncBus 1* When selected a positive edge on the SyncBus 1 line will start the pacer clock.
- *SyncBus 2* When selected a positive edge on the SyncBus 2 line will start the pacer clock.

The following start trigger sources provide delayed triggering. When the trigger is issued, the A/D delay counter - see Figure 4.1.5. -, counts down and conversions are started when the A/D delay counter reaches 0. The A/D delay counter counts at the pacer clock rate.

- *Delayed Software Pacer Start.* When selected, a read at LAS0+14h will start the delay counter.
- *Delayed external trigger.* When selected, a positive- or negative-going edge (depending on the setting of the trigger polarity, bit 11 in the Control Register) on the external TRIGGER INPUT line, will start the delay counter. The pulse duration should be at least 100 nanoseconds.
- *Delayed digital interrupt.* When selected, a digital interrupt will start the delay counter.
- *Delayed User TC Counter 2 output.* When selected, a pulse on the Counter 2 output line (Counter 2's count reaches 0) will start the delay counter.
- *Delayed SyncBus 0.* When selected, a pulse on the SyncBus0 will start the delay counter.
- *Delayed SyncBus 1.* When selected, a pulse on the SyncBus1 will start the delay counter.
- *Delayed SyncBus 2.* When selected, a pulse on the SyncBus2 will start the delay counter.
- *External Trigger Gated mode.* When selected, the pacer clock runs when the external TRIGGER INPUT line is held high. When this line goes low, conversions stop. This trigger mode does not use a stop trigger. If the trigger polarity bit is set for negative, the pacer clock runs when this line is low and stops when it is taken high.

**The Pacer Clock stop trigger sources are:**

- *Software Pacer Stop trigger.* When selected, a write at LAS0+14h will stop the Pacer Clock.
- *External trigger.* When selected, a positive- or negative-going edge (depending on the setting of the trigger polarity, setting up by Function 0x602) on the external TRIGGER INPUT line, will stop the Pacer Clock. The pulse duration should be at least 100 nanoseconds.
- *Digital interrupt.* When selected, a digital interrupt will stop the pacer clock.
- *About Counter.* When selected, the Pacer Clock stops when the About Counter's count reaches 0. About Counter counts samples which are written into the A/D FIFO
- *User TC2 out* When selected, the Pacer Clock stops when the User TC 2 counter's count reaches 0.
- *SyncBus0.. 2 signals* When selected, the Pacer Clock stops when there is a rising edge on the SyncBus line.

The next stop trigger sources provide about triggering, where data is acquired from the time the start trigger is received, and continues for a specified number of samples after the stop trigger. The number of samples to acquire after the stop trigger is programmed in the About Counter. About Counter counts samples which are written into the A/D FIFO

- *About Software Pacer Stop trigger.* When selected, a Software Pacer Stop trigger starts the About counter, and sampling continues until the About Counter's count reaches 0.
- *About external trigger.* When selected, an external trigger starts the About counter, and sampling continues until the sample counter's count reaches 0.
- *About digital interrupt.* When selected, a digital interrupt starts the About Counter, and sampling continues until the About Counter's count reaches 0.
- *About User TC Counter 2 output.* When selected, a pulse on the User Timer Counter 2 output line (Counter 2's count reaches 0) starts the About Counter, and sampling continues until the About Counter's count reaches 0.
- *About SyncBus0.. 2.* When selected, a rising edge on SyncBus0..2 starts the About Counter, and sampling continues until the About Counter's count reaches 0.

Note that the external trigger (TRIGGER INPUT) can be set to occur on a positive-going edge or a negative-going edge, depending on the setting up the Function 0x0602.

### **Burst Clock Start Trigger to trigger burst sample.**

The following paragraph describes the operation when the A/D conversion start signal is selected as Burst Clock. Burst clock is an output of Timer Counter See Figure 4.1.4. The clock signal of the Burst Clock Timer Counter is 8MHz. The gate signal of this TC is used to start and stop the Burst Clock. The start signal can be select from the following list, and the stop is derived from the empty signal of Channel Gain Table. The Burst Clock operation belongs to the multichannel - Channel Gain Table operation.

The start triggers can be set by Function 0x0201:

- *Software A/D start* (by writing LAS0+8h)
- *Pacer Clock* (internal or external )
- *external TRIGGER INPUT*
- *Digital Interrupt*
- *SyncBus0.. 2*

### **Single Cycle Mode, Trigger Repeat mode.**

Using the Pacer Start Mode select Function 0x0205 the Single Cycle mode or the Trigger Repeat Mode can be selected. This function controls the conversion sequence when using a trigger to start the Pacer Clock. When the Function argument is low, the first pulse on the selected Pacer Clock Start Trigger source will start the pacer clock. After the stop trigger has ended the conversion cycle, the triggering circuit is disarmed and must be rearmed before another start trigger can be recognized. To rearm this trigger circuit, you must issue a Software A/D Start command (Write LAS0+8h).

When Function argument is high, the conversion sequence is repeated each time a selected Pacer Clock Start Trigger is received.

### **Pacer Clock Source.**

The Pacer Clock can be generated from an internal source or an external source using the Function 0x0509.

## **5.2.3. Types of Conversions**

### **Single Conversion.**

In this mode, a single specified channel is sampled whenever the Software A/D Start Command is occurred. The active channel is the one specified in the Channel Gain Latch. This is the easiest of all conversions. It can be used in a wide variety of applications, such as sample every time a key is pressed on the keyboard, sample with each iteration of a loop, or watch the system clock and sample every five seconds.

### **Multiple Conversions.**

In this mode, conversions are continuously performed at the Pacer Clock rate, or other selected A/D Conversion Signal rate. The pacer clock can be internal or external. The maximum rate supported by the board is 1.25MHz. The Pacer Clock can be turned on and off using any of the start and stop triggering modes using the Function 0x202, and 0x203. If you use the internal pacer clock, you must program it to run at the desired rate.

This mode is ideal for filling arrays, acquiring data for a specified period of time, and taking a specified number of samples.

### **Random Channel Scan.**

In this mode, the Channel Gain Table is incrementally scanned through, with each selected A/D Conversion Signal pulse starting a conversion at the channel and gain specified in the current table entry. Before starting a conversion sequence Channel Gain Table, you need to load the table with the desired data. Then make sure that the Channel Gain Table is enabled by the Function 0x0303. This enables the A/D portion of the Channel Gain Table. If you are using the Digital Table as well, you must also enable this using the Function 0x0304. Each rising edge of selected A/D Conversion Signal starts a conversion using the current Channel Gain data and then increments to the next position in the table. When the last entry is reached, the next pulse starts the table over again.

### **Programmable Burst.**

In this mode, a single trigger initiates a scan of the entire Channel-gain table. Before starting a burst of the channel-gain table, you need to load the table with the desired data. Then make sure that the channel-gain table is enabled. If you are using the Digital Table as well, you must also enable it.

Burst is used when you want one sample from a specified number of channels for each trigger. The burst trigger, which is a trigger or pacer clock, triggers the burst and the burst clock initiates each conversion. At high speeds, the burst mode emulates simultaneous sampling of multiple input channels. For time critical simultaneous sampling applications, a simultaneous sample-and-hold board can be used (SS8 eight-channel boards are available from Real Time Devices).

### **Programmable Multiscan.**

This mode - when the A/D Conversion Start Signal is the Burst Clock - lets you scan the Channel Gain Table after a Burst Clock Start Signal. When the Channel Gain Table is empty the Burst Clock is stopped, and waiting for a new Start Signal.

As you can see, the PCI4520/DM7520/DM7540 is designed to support a wide range of conversion requirements. You can set the clocks, triggers, and channel and gain to a number of configurations to perform simple or very complex acquisition schemes where multiple bursts are taken at timed intervals. Remember that the key to configuring the board for your application is to understand what signals can actually control conversions and what signals serve as triggers. The discussions presented in this section and the example programs on the disk should help you to understand how to configure the board.

### **Starting an A/D Conversion**

Depending on your conversion and trigger settings, the Software A/D Start command (Write LAS0 + 010h) has different functions. In any mode that uses the Software A/D Start command, this command will do the appropriate action. In any mode that does not use the Software A/D Start command as the trigger, you will still need to do a write the LAS0 + 010h to arm (enable) the triggering circuitry. An example of this would be, if you set the Pacer Clock Start Trigger as external trigger, write the LAS0 + 010h is required to arm the external trigger circuitry. After you have set all the trigger and conversion registers to the proper values, the last command will need to be Software A/D Start. Any external triggers received before this command will be ignored. It is also a good practice to clear the A/D FIFO just prior to triggering the measurement or arming the trigger. Study the example programs to see this sequence.

### **Conversion Status Monitoring**

The A/D conversion status can be monitored through the A/D FIFO empty flag in the FIFO status word read at LAS0+8h. Typically, you will want to monitor the Empty flag (active low) for a transition from low to high. This tells you that a conversion is complete and data has been placed in the sample buffer.

### Halting Conversions

In single convert modes, a single conversion is performed and the module waits for another Software A/D Start command. In multi-convert modes, conversions are halted by one of two methods: when a stop trigger has been issued to stop the pacer clock, or when the FIFO is full. The Pacer Clock Shut Down Flag, bit 4 of the status word (LAS0 + 02Ch), is set when the sample buffer is full, disabling the A/D converter. Even if you've removed data from the sample buffer since the buffer filled up and the FIFO full flag is no longer set, the The Pacer Clock Shut Down Flag will confirm that at some point in your conversion sequence, the sample buffer filled and conversions were halted. At this point a clear A/D FIFO command must be issued and a Software A/D Start convert (write at LAS0 + 010h) to rearm the trigger circuitry.

### 5.3. Reading the Converted Data

Each 12-bit conversion is stored in a 16-bit word in the sample buffer, in the A/D FIFO. The buffer can store 1024 samples. This section explains how to read the data stored in the sample buffer.

The sample buffer - A/D FIFO contains the converted data and 3-bit data marker (if used) in a 16-bit word.

The 12-bit A/D data + sign bit is left justified in a 16-bit word, with the least significant three bits reserved for the data marker. Because of this, the A/D data read must be scaled to obtain a valid A/D reading. The data marker portion should be masked out of the final A/D result. Shifting the word three bits to the right will eliminate the data marker from the data word. If you are using the data marker, then you should preserve these bits someplace in your program.

The output code format is always two's complement. This is true for both bipolar and unipolar signals since the sign bit is added above the 12-bit conversion data. For bipolar conversions, the sign bit will follow the MSB of the 12-bit data. If this bit is a "0", the reading is a positive value. If this bit is a "1", the reading is a negative value. When the input is a unipolar range, the coding is the same except that the sign bit is always a "0" indicating a positive value. The data should always be read from the A/D FIFO as a signed integer.

Voltage values for each bit will vary depending on input range and gain. For example, if the input is set for  $\pm 5$  volts and the gain = 1, the formula for calculating voltage is as follows:

$$\text{Voltage} = ((\text{input range} / \text{Gain}) / 4096) \times \text{Conversion Data}$$

$$\text{Voltage} = ((10 / 1) / 4096) \times \text{Conversion Data}$$

$$\text{Voltage} = 2.44 \text{ mV} \times \text{Conversion Data}$$

Remember that when you change the gain, you are increasing the resolution of the bit value but you are decreasing the input range. In the above example if we change the gain to 4, each bit will now be equal to 610  $\mu\text{V}$  but our input range is decreased from 10 volts to 2.5 volts. The formula would look like this:

$$\text{Voltage} = ((\text{input range} / \text{Gain}) / 4096) \times \text{Conversion Data}$$

$$\text{Voltage} = ((10 / 4) / 4096) \times \text{Conversion Data}$$

$$\text{Voltage} = 610 \text{ uV} \times \text{Conversion Data}$$

If we now change the input range to  $\pm 10$  volts and the gain = 1, the formula would be:

$$\text{Voltage} = ((\text{input range} / \text{Gain}) / 4096) \times \text{Conversion Data}$$

$$\text{Voltage} = ((20 / 1) / 4096) \times \text{Conversion Data}$$

$$\text{Voltage} = 4.88 \text{ mV} \times \text{Conversion Data}$$

### 5.4. Using the A/D Data Markers

For certain applications where you may want to store digital information with the analog data at the same rate the analog data is being acquired, the bottom three bits of the converted data are available for this feature. For example, you may want to tag the acquired data with a marker so that you know when the data

was sampled. Three lines are available at I/O connector to send the data marker settings to the sample buffer along with the 12-bit A/D converted data. These lines are P0.5, P0.6 and P0.7.

### 5.5. Programming the Pacer Clock

The PCI4520/DM7520/DM7540 has a 24 bit count down on-board pacer clock with 8MHz/20MHz clock signal. When you want to use the pacer clock for continuous A/D conversions, you must select the Pacer Clock as A/D Conversion Signal and program the clock rate.

The pacer clock is accessed for programming at LAS0 + 040 address. To find the value you must load into the clock to produce the desired rate, you first have to calculate the value of Divider for the 24-bit clock. The formulas for making this calculation are as follows:

$$\text{Pacer Clock frequency} = 8 / 20 \text{ MHz} / (\text{Divider} + 1)$$

$$\text{Divider} = (8 \text{ MHz} / \text{Pacer Clock Frequency}) - 1$$

The Pacer Clock frequency range is 1.14 MHz.. 0.47Hz defined by the 8MHz clock frequency, the 24bit wide counter and the 1.25MHz maximum Sampling frequency.

| Pacer Clock  | Sampling Cycle Time | Pacer Clock   | Sampling Cycle Time | Divider (decimal) |
|--|---------------------|---|---------------------|-------------------|
| Primary clock - 8MHz<br>See Function 0X0501 (1DCh) |                     | Primary clock - 20MHz<br>See Function 0X0501 (1DCh) |                     |                   |
| 1.14MHz  | 877ns               | -   | -                   | 6                 |
| 1MHz   | 1us                 | -   | -                   | 7                 |
| 888.89kHz  | 1.125us             | -   | -                   | 8                 |
| 800kHz   | 1.25us              | -   | -                   | 9                 |
| 500kHz   | 2us                 | 1.25MHz   | 800ns               | 15                |
| 470.588kHz   | 2.15us              | 1.176MHz  | 850ns               | 16                |
| .  | .                   | .   | .                   | .                 |
| 100kHz   | 10us                | 250kHz  | 4us                 | 79                |
| .  | .                   | .   | .                   | .                 |
| 50kHz  | 20us                | 125kHz  | 8us                 | 159               |
| 10kHz  | 100us               | 25kHz   | 40us                | 799               |
| 1kHz   | 1ms                 | 2.5kHz  | 0.4ms               | 7999              |
| 100Hz  | 10ms                | 250Hz   | 4ms                 | 79999             |
| 10Hz   | 100ms               | 25Hz  | 40ms                | 799999            |
| 1Hz  | 1s                  | 2.5Hz   | 0.4s                | 7 999 999         |
| 477mHz   | 2.09s               | 1.19Hz  | 0.84s               | 16 777 216        |

Table 5.5.1.

Writing the Divide r into the LAS0 + 040h the Pacer Clock works immediately according to this value. Writing process clears the Counter - generates a Pacer Clock pulse, and loads the Divider value to the Counter.

### 5.6. Programming the Burst Clock

The PCI4520/DM7520/DM7540 has a 16-bit count down on-board Burst Clock timer with 8 / 20MHz clock signal. When you want to use the Burst Clock for performing A/D conversions in the burst mode, you must program the clock rate by writing the LAS0 + 044h. To find the Divider value you must load into the Burst Clock Counter to produce the desired rate, make the following calculation:

The Burst Clock Frequency Range is 1.14MHz.. 122Hz – 8MHz primary clock, and 1.25MHz.. 305Hz – 20MHz primary clock.

$$\text{Burst Clock Frequency} = 8 / 20 \text{ MHz} / (\text{Divider}+1)$$

$$\text{Divider} = (8 / 20 \text{ MHz} / \text{Pacer Clock Frequency}) - 1$$

| Burst Clock  | Burst Clock Cycle Time | Burst Clock   | Burst Clock Cycle Time | Divider (decimal) |
|--|------------------------|---|------------------------|-------------------|
| Primary clock - 8MHz<br>See Function 0X0502 (1E0h) |                        | Primary clock - 20MHz<br>See Function 0X0502 (1E0h) |                        |                   |
| 1.14MHz  | 877ns                  | -   | -                      | 6                 |
| 1MHz   | 1us                    | -   | -                      | 7                 |
| 888.89kHz  | 1.125us                | -   | -                      | 8                 |
| 800kHz   | 1.25us                 | -   | -                      | 9                 |
| 500kHz   | 2us                    | 1.25MHz   | 800ns                  | 15                |
| 100kHz   | 10us                   | 250kHz  | 4us                    | 79                |
| 50kHz  | 20us                   | 125kHz  | 8us                    | 159               |
| 10kHz  | 100us                  | 25kHz   | 40us                   | 799               |
| 122Hz  | 8.1ms                  | 305.17Hz  | 3.2ms                  | 65535             |

Table 5.5.2.

F.e. to set the burst clock frequency at 100 kHz, this equation becomes:

$$\text{Divider} = (8 \text{ MHz} / \text{Pacer Clock Frequency}) - 1 = 8\text{MHz}/100\text{kHz} - 1 = 79$$

After you determine the divider value that will result in the desired clock frequency, write it into the LAS0 + 044h. Writing the Divider into the LAS0 + 044h the Burst Clock works immediately according to this value. Writing process clears the Counter - generates a Burst Clock pulse, and loads the Divider value to the Counter.

### 5.7. Programming the About Counter

The About Counter lets you program the PCI4520/DM7520/DM7540 to take a certain number of samples and then halt conversions. (Select A/D Conversion Signal to Pacer Clock, select the Pacer Clock Stop Trigger to About Counter) The number of samples minus one to be taken is loaded into the 16-bit About Counter at LAS0 + 058h.

Note that once the counter is properly loaded and starts, any subsequent countdowns of this count will be accurate.

After you determine the desired number of samples, load the number minus 1 to the About Counter register.

#### 5.7.1. Using the About Counter to Create Large Data Arrays

The 16-bit About Counter allows you to take up to 65,535 samples before the count reaches 0 and sampling is halted. Suppose, however, you want to take 100,000 samples and stop. The PCI4520/DM7520/DM7540 provides a Function, About Counter Stop Enable 0x0204 which allows you to use the About counter to take more than 65,535 samples in a conversion sequence.

The About Counter stop enable bit can be set to 1 to allow the sample counter to continuously cycle through the loaded count until the stop enable bit is set to 0, which then causes the sample counter to stop at the end of the current cycle. Let’s look back at our example where we want to take 100,000 readings. First, we must divide 100,000 by a whole number that gives a result of less than 65,535. In our example, we can divide as follows:

$$\text{Sample Counter Count} = 100,000 / 2 = 50,000$$

To use the sample counter to take 100,000 samples, we will load a value of 50,000 into the counter and cycle the counter two times. After the value is loaded, make sure that the Stop Bit is set to 1 so that the sample counter will cycle. Then, set up the sample counter so that it generates an interrupt when the count reaches 0. Initialize the sample counter as described in the preceding section and start the conversion sequence. When the sample counter interrupt occurs telling you that the count has reached 0 and the cycle is starting again, set the Stop Bit to 0 to stop the sample counter after the second cycle is completed. The result: the sample counter runs through the count two times and 100,000 samples are taken.

## 6. D/A Conversion

This chapter explains how to perform D/A conversions on the PCI4520/DM7520/DM7540.

Two independent 12-bit analog output channels are included on the PCI4520/DM7520/DM7540. The analog outputs are generated by two 12-bit D/A converters with independent software programmable output ranges. Each D/A channel has 1KSample D/A FIFO. The analog output signals are accompanied by two digital data markers, DM0, and DM1. The DM0 bits are buffered and wired to the External I/O Connector. The DM1 bits may be the Start Conversion Signal of A/D converter. The digital data markers are updated simultaneously with the analog output signal.

D/A1 data is written to LAS1 + 8h and D/A2 data is written to LAS1 + Ch. The data are written into the D/A FIFOs, and the Update signals read the FIFOs, and update the D/A converters.

The configuration of D/A channels can be done by D/A1 and D/A2 Function groups (0x400.. 0x040F).

The Function 0x0400 (0x0407 for D/A2) sets the voltage output range and polarity for D/A1. The output ranges are ±5, ±10, 0 to +5, or 0 to +10 volts.

The Function 0x0401 selects the update source for D/A1:

- *Software D/A1 Update.* Write a dummy data to LAS0+14h. (LAS0+18h for D/A2)
- *CGT Controlled D/A1 Update* If the D12 (D13 for D/A2) bit of CGT is 1 the D/A1 is updated simultaneously with the A/D sampled analog input
- *DAC Clock* The 16/(24bit - DM7520/DM7540) D/A clock inside the control logic.

The PCI4520/DM7520/DM7540 has a 16-bit count down on-board DAC Clock timer with 8 / 20MHz clock signal. When you want to use the DAC Clock for performing D/A conversions in the burst mode, you must program the clock rate by writing the LAS0 + 05Ch. To find the Divider value you must load into the DAC Clock Counter to produce the desired rate, make the following calculation:

The DAC Clock Frequency Range is 200kHz.. 0.47Hz – 8MHz primary clock, and 200kHz.. 1.19Hz – 20MHz primary clock.

$$\text{Burst Clock Frequency} = 8 / 20 \text{ MHz} / (\text{Divider}+1)$$

$$\text{Divider} = (8 / 20 \text{ MHz} / \text{Pacer Clock Frequency}) - 1$$

| DAC Clock  | DAC Clock Cycle Time | DAC Clock   | DAC Clock Cycle Time | Divider (decimal) |
|--|----------------------|---|----------------------|-------------------|
| Primary clock - 8MHz<br>See Function 0X0503 (1E4h) |                      | Primary clock - 20MHz<br>See Function 0X0503 (1E4h) |                      |                   |
| 200kHz   | 5us                  | -   | -                    | 39                |
| 195.1kHz   | 5.125us              | -   | -                    | 40                |
| 80kHz  | 12.5us               | 200kHz  | 5us                  | 99                |
| 79208Hz  | 12.625us             | 198.02kHz   | 5.05us               | 100               |
| 10kHz  | 100us                | 25kHz   | 40us                 | 799               |
| 8kHz   | 125us                | 20kHz   | 50us                 | 999               |
| 0.47Hz   | 8.1ms                | 1.19Hz  | 0.838s               | 16777215          |

Table 6.1.

F.e. to set the DAC clock frequency at 100 kHz, this equation becomes:

$$\text{Divider} = (8 \text{ MHz} / \text{DAC Clock Frequency}) - 1 = 8\text{MHz}/100\text{kHz} - 1 = 79$$

After you determine the divider value that will result in the desired clock frequency, write it into the LAS0 + 05Ch. Writing the Divider into the LAS0 + 05Ch the DAC Clock works immediately according to this value. Writing process clears the Counter - generates a DAC Clock pulse, and loads the Divider value to the Counter. Note, that the DAC clock needs a start command.

- *External Pacer Clock* The rising edge of External Pacer Clock at the external I/O Connector updates the D/A1. The minimum pulse width is 100ns.
- *SyncBus0.. 2* The rising edge of SyncBus signals updates the D/A1. The source of SyncBus signals may be on the same board or on another PCI4520/DM7520/DM7540 board.

The Function 0x0402 (0x040A for D/A2) selects the cycled or not cycled mode for D/A1. In the case of cycled mode, emptying the D/A1 FIFO the Update pointer of the FIFO is set to the beginning of the data array in the FIFO. This mode can be used for generating periodic signals without any processor intervention. This means that setting this bit to a 1, the D/A1 will continuously repeat the data that is stored in the D/A1 FIFO. This is useful for waveform generation. The not cycled mode is the normal operation mode.

The Function 0x0406 (0x040E for D/A2) resets the D/A1 FIFO. This Function sets the update pointer of the D/A1 FIFO to the beginning of the data array in the FIFO.

The Function 0x0407 (0x0410 for D/A2) clears the D/A1 FIFO. This Function sets the update and write pointer of the D/A1 FIFO to the beginning of. This means that the FIFO is ready to fill with new data.

The following tables list the key digital codes and corresponding output voltages for the D/A converters.

| Bipolar<br>D/A Bit Weight | Ideal Output Voltage (millivolts) |                  |
|---------------------------|-----------------------------------|------------------|
|                           | -5 to +5 Volts                    | -10 to +10 Volts |
| 2047                      | +4997.56                          | +9995.12         |
| 1024                      | +2500.00                          | +5000.00         |
| 512                       | +1250.00                          | +2500.00         |
| 256                       | +625.00                           | +1250.00         |
| 128                       | +312.50                           | +625.00          |
| 64                        | +156.25                           | +312.50          |
| 32                        | +78.13                            | +156.25          |
| 16                        | +39.06                            | +78.13           |
| 8                         | +19.53                            | +39.06           |
| 4                         | +9.77                             | +19.53           |
| 2                         | +4.88                             | +9.77            |
| 1                         | +2.44                             | +4.88            |
| 0                         | 0.00                              | 0.00             |
| -1                        | -2.44                             | -4.88            |
| -2                        | -4.88                             | -9.77            |
| -4                        | -9.77                             | -19.53           |
| -8                        | -19.53                            | -39.06           |
| -16                       | -39.06                            | -78.13           |
| -32                       | -78.13                            | -156.25          |
| -64                       | -156.25                           | -312.50          |
| -128                      | -312.50                           | -625.00          |
| -256                      | -625.00                           | -1250.00         |
| -512                      | -1250.00                          | -2500.00         |
| -1024                     | -2500.00                          | -5000.00         |
| -2048                     | -5000.00                          | -10000.00        |

| Unipolar<br>D/A Bit Weight | Ideal Output Voltage (millivolts) |                |
|----------------------------|-----------------------------------|----------------|
|                            | 0 to +5 Volts                     | 0 to +10 Volts |
| 4095                       | +4998.78                          | +9997.56       |
| 2048                       | +2500.00                          | +5000.00       |
| 1024                       | +1250.00                          | +2500.00       |
| 512                        | +625.00                           | +1250.00       |
| 256                        | +312.50                           | +625.00        |
| 128                        | +156.25                           | +312.50        |
| 64                         | +78.13                            | +156.25        |
| 32                         | +39.06                            | +78.13         |
| 16                         | +19.53                            | +39.06         |
| 8                          | +9.77                             | +19.53         |
| 4                          | +4.88                             | +9.77          |
| 2                          | +2.44                             | +4.88          |
| 1                          | +1.22                             | +2.44          |
| 0                          | 0.00                              | 0.00           |

### 6.1. 1024 Sample Buffer

Each D/A channel has a 1024 sample buffer for storing data to be sent to the D/A converter (D/A FIFO). This means that you can fill the buffer with data and set up the D/A to output this data automatically. This is very useful for outputting high speed data or generating waveforms with precise timing requirements. By setting the cycled mode, you can fill the buffer with one cycle of a wave, start the D/A update clock and the buffer will continue to repeat until the clock is stopped. Combining this feature with the variety of update sources, you can build a flexible waveform generator.

If you are trying to generate a non-repetitive waveform, you can combine the sample buffer capability with the D/A Update Counter. To utilize this feature of the PCI4520/DM7520/DM7540 properly, you should load the buffer with data, program the D/A Update Counter for half the buffer size (512 samples) and use the Update Counter to generate an interrupt. When an interrupt is received, you should reload the buffer with 512 new samples. By continuing this cycle, you can generate a non-repetitive waveform at high speeds.

Status of the FIFO buffers can be monitored at LAS0 + 010h. Any samples that are written to the FIFO after it is full will be ignored. You can write up to 1024 samples to the buffer before it is full. Each update pulse (either software or from one of the clocks) will remove a sample from the buffer and send it out the D/A. Each update - read after the FIFO buffer is empty will be ignored, and the output of the D/A remains in the last updated state.

At power-up or reset, the D/A outputs are set to 0 volts. Before loading data into the sample buffer it is best to clear the buffer by Function 0x0407 or 0x040F. When you issue the "Clear D/A FIFO" command, all data in the buffer is erased. If you issue the "Reset DAC FIFO" command, the data in the buffer is not erased, however the address pointer is set back to the beginning of the buffer: This is useful when you are generating waveforms and stop the updating in the middle of a cycle.

## **6.2. D/A Cycled or Not Cycled Mode**

The cycle bit is used to make the buffer data repeat. Under normal operation, without the cycled mode set, data is written into the buffer and the update clock reads data out of the buffer. When the buffer is empty, the output of the D/A remains. If you set the cycle bit high, the data in the buffer will repeat. If you load a data set into the buffer, when the update clock reaches the end of the data it will automatically wrap around to the beginning and start over. This is useful for generating waveforms.

## **6.3. D/A Update Counters**

The D/A1 and D/A2 16 bit wide Update Counters, are useful when using clocks to output data to the D/As. The counters can be accessed at LAS0 + 04Ch, ill LAS0 + 050h addresses. These counters will count update pulses sent to the D/A's and can be polled to read the current count or can be used to generate interrupts when the count reaches 0. These counters can be loaded to any starting value and count down. When the count reaches 0 it will automatically be reloaded with the original starting value.

## **6.4. D/A Data Markers**

The D/A Data Markers are used to send out digital pulses synchronized to the D/A analog output. Since each D/A FIFO buffer is 16 bits wide and the D/A only uses 12 bits, there are bits left for Data Markers. Two of these bit locations can be filled with data and this data is sent out on the appropriate pins synchronized to the D/A analog output. This is useful for sending out a trigger pulse each time a waveform crosses zero or to send out pulses to trigger A/D conversions at the proper time in the D/A waveform. Each D/A channel has 2 Data Marker bits. The DM0 outputs can be accessed at the external I/O connector

## 7. Data transfer using DMA

The PCI9080, the PCI controller chip of PCI4520/DM7520/DM7540 supports two independent DMA channels capable of transferring data from the Local Bus to the PCI Bus or from the PCI Bus to the Local Bus. Each channel consists of a DMA controller and a programmable FIFO. Both channels support Chaining and Non-chaining transfers, Demand mode DMA, and End of Transfer (EOT) pins. Master mode must be enabled in the PCI Command register. We use the Demand mode DMA and do not use the EOT pins on the PCI4520/DM7520/DM7540 Board.

The DMA transfer on the PCI4520/DM7520/DM7540 can be used for reading or writing the LAS1 address area which contains the input and output FIFOs. Using the onboard DMA controllers we can transfer our data in burst mode, without CPU intervention. The Data transfer may be single cycle - Non-Chaining Mode or multiply cycle - Chaining mode.

The PCI4520/DM7520/DM7540 uses the demand mode DMA. This means that the DMA transfer is started by a programmable hardware event. (See 7.3.1.)

### 7.1 Non-Chaining Mode DMA

The host processor sets the Local Address (LAS1 FIFO address), PCI Address, transfer count and transfer direction. The host processor then sets a control bit to initiate the transfer or in Demand Mode a DMA request event can initiate the transfer. The PCI 9080 arbitrates the PCI and Local Buses and transfer data. Once the transfer is complete, the PCI 9080 sets the Channel Done bit to a value of 1 and generates an interrupt to the PCI Host (programmable). DMA Done bit in the internal DMA register can be pooled to indicate the status of DMA transfer. DMA registers are accessible from the PCI Bus and Local Bus.

The Local processor or PCI requires DMA. The PCI 9080 is Master on both the PCI and Local Buses. Direct Slave or Direct Master pre-empts DMA. The PCI 9080 releases the PCI Bus if one of the following occurs :

- FIFO (of PCI9080) is full
- Terminal count is reached
- PCI Latency Timer (PCILTR[7:0]) expires—normally programmed by the Host PCI BIOS—and PCI GNT# de-asserts
- PCI Host asserts STOP
- Direct Master request pending

The PCI9080 releases the Local Bus if one of the following occurs

- FIFO (of PCI9080) is empty
- Terminal count is reached
- Local Bus Latency Timer (MARBR[7:0]) expires
- BREQ# input is asserted
- Direct Slave request is pending

### 7.2 Chaining Mode DMA

In Chaining mode DMA, the Host Processor sets up descriptor blocks in local or host memory that are composed of a PCI Address, Local Address, transfer count, transfer direction, and address of the next descriptor block (refer to Figure 3-18). Host then sets up the address of the initial descriptor block in the Descriptor Pointer register of the PCI9080 and initiates the transfer by setting a control bit. The PCI9080 loads the first descriptor block and initiates the Data transfer. The PCI 9080 continues to load descriptor blocks and transfer data until it detects the End of Chain bit is set in the Next Descriptor Pointer register. The PCI9080 can be programmed to interrupt the Local processor by setting the Interrupt after Terminal Count bit or PCI Host upon completion of each block transfer and after all block transfers are complete (done). If chaining descriptors are located in Local memory, the DMA controller can be programmed to clear the transfer size at the completion of each DMA (DMAMODE0[16] and DMAMODE1[16]).

**Notes:** In Chaining mode DMA, the descriptor includes PCI Address, Local Address, Transfer Size and the Next Descriptor Pointer (DMAPADR0-DMADPR0). The Descriptor Pointer register contains the End of Chain bit, Direction of Transfer, Next Descriptor Address, and Next Descriptor Location. The DMA descriptor can be on Local or PCI memory, or both (first descriptor on Local memory, and second descriptor on PCI memory).

### **7.3 DMA Data Transfers**

The PCI 9080 DMA controller can be programmed to transfer data from the Local Bus side to the PCI Bus side or from the PCI Bus side to the Local Bus side.

#### **7.3.1 Demand Mode DMA**

The Demand Mode DMA is used on the PCI4520/DM7520/DM7540 board. This means that a programmable hardware event generate DREQ0 or DREQ1 signal for the DMA controller to start the DMA transfer. Before this process the DMA registers must be initialized by software.

You can select from the following DMA request sources by writing the LAS0+101h and LAS0+102h the addresses:

0x0 = A/D Sample Counter   
0x1 = D/A1 Sample Counter  
0x2 = D/A2 Sample Counter  
0x3 = User TC 1

The Counter values must be integer\*2 because the Demand mode DMA transfers longwords.

#### **7.3.2. DMA Priority**

DMA Channel 0 priority, DMA Channel 1 priority, or rotating priority can be specified in the DMA Arbitration register.

## 7.4 DMA Registers

The DMA operation is controlled via the DMA registers:

| PCI<br>(Offset<br>from<br>PCIBAR0<br>Base<br>Address) | Local<br>Access<br>(Offset<br>from Chip<br>Select<br>Address) | To ensure software compatibility with other versions of<br>the PCI 9080 family and to ensure compatibility with<br>future enhancements, write 0 to all unused bits. |   |   | PCI/<br>Local<br>Writable | Serial<br>EEPROM<br>Writable |
|---|---|---|---|---|---------------------------|------------------------------|
|   |   | 31  |   |   |                           |                              |
| 80h   | 100h  | DMA Ch 0 Mode   |   |   | Y                         | N                            |
| 84h   | 104h  | DMA Ch 0 PCI Address  |   |   | Y                         | N                            |
| 88h   | 108h  | DMA Ch 0 Local Address  |   |   | Y                         | N                            |
| 8Ch   | 10Ch  | DMA Ch 0 Transfer Byte Count  |   |   | Y                         | N                            |
| 90h   | 110h  | DMA Ch 0 Descriptor Pointer   |   |   | Y                         | N                            |
| 94h   | 114h  | DMA Ch 1 Mode   |   |   | Y                         | N                            |
| 98h   | 118h  | DMA Ch 1 PCI Address  |   |   | Y                         | N                            |
| 9Ch   | 11Ch  | DMA Ch 1 Local Address  |   |   | Y                         | N                            |
| A0h   | 120h  | DMA Ch 1 Transfer Byte Count  |   |   | Y                         | N                            |
| A4h   | 124h  | DMA Ch 1 Descriptor Pointer   |   |   | Y                         | N                            |
| A8h   | 128h  | Reserved  | DMA Channel1<br>Command/<br>Status Register | DMA Channel0<br>Command/<br>Status Register | Y                         | N                            |
| ACh   | 12Ch  | Mode/Arbitration Register   |   |   | Y                         | N                            |
| B0h   | 130h  | DMA Threshold Register  |   |   | Y                         | N                            |

Table 7.1. DMA Registers

**7.4.1. (DMAMODE0; PCI:80h) DMA Channel 0 Mode Register**

| Bit   | Description   | Read | Write | Value after Reset          | Value in PCI4520 DM7520 |
|-------|---|------|-------|----------------------------|-------------------------|
| 1:0   | Local Bus Width. Value of 00 indicates bus width of 8 bits. Value of 01 indicates bus width of 16 bits. Value of 10 or 11 indicates bus width of 32 bits.   | Yes  | Yes   | S = 01<br>J = 11<br>C = 11 | <b>01</b>               |
| 5:2   | Internal Wait States (data to data).  | Yes  | Yes   | 0                          | <b>000</b>              |
| 6     | Ready Input Enable. Value of 1 enables Ready input. Value of 0 disables Ready input.  | Yes  | Yes   | 0                          | <b>1</b>                |
| 7     | BTERM# Input Enable. Value of 1 enables BTERM# input. Value of 0 disables BTERM# input. If set to 0, the PCI 9080 bursts four Lword maximum at a time.  | Yes  | Yes   | 0                          | <b>0</b>                |
| 8     | Local Burst Enable. Value of 1 enables bursting. Value of 0 disables local bursting. If burst is disabled, Local Bus performs continuous single cycles for Burst PCI Read/Write cycles.   | Yes  | Yes   | 0                          | <b>1</b>                |
| 9     | Chaining. Value of 1 indicates Chaining mode is enabled. For Chaining mode, DMA source address, destination address and byte count are loaded from memory in PCaddress Spaces. Value of 0 indicates Non-chaining mode is enabled.   | Yes  | Yes   | 0                          | <b>1 or 0</b>           |
| 10    | Done Interrupt Enable. Value of 1 enables interrupt when done. Value of 0 disables interrupt when done. If DMA Clear Count mode is enabled, interrupt does not occur until byte count is cleared.   | Yes  | Yes   | 0                          | <b>1 or 0</b>           |
| 11    | Local Addressing Mode. Value of 1 indicates Local Address LA[31:2] to be held constant. Value of 0 indicates Local Address is incremented.  | Yes  | Yes   |                            | <b>1</b>                |
| 12    | Demand Mode. Value of 1 causes DMA controller to operate in Demand mode. In Demand mode, DMA controller transfers data when its DREQ[1:0]# input is asserted. Asserts DACK[1:0]# to indicate current Local Bus transfer is in response to DREQ[1:0]# input. DMA controller transfers Lwords (32 bits) of data. May result in multiple transfers for 8- or 16-bit bus  | Yes  | Yes   | 0                          | <b>1</b>                |
| 13    | Write and Invalidate Mode for DMA Transfers. When set to 1, the PCI 9080 performs Write and Invalidate cycles to PCI Bus. The PCI 9080 supports Write and Invalidate sizes of 8 or 16 Lwords. Size specified in PCI Cache Line Size Register. If size other than 8 or 16 is specified, the PCI 9080 performs Write transfers rather than Write and Invalidate transfers. Transfers must start and end at Cache Line boundaries. | Yes  | Yes   | 0                          | <b>0</b>                |
| 14    | DMA EOT (End of Transfer) Enable. Value of 1 enables EOT[1:0]# input pin. Value of 0 disables EOT[1:0]# input pin.  | Yes  | Yes   | 0                          | <b>0</b>                |
| 15    | DMA Stop Data Transfer Mode. Value of 0 sends BLAST to terminate DMA transfer. Value of 1 indicates EOT asserted or DREQ[1:0]# de-asserted during Demand mode DMA terminates a DMA transfer. (Refer to Section 3.7.6.1, "End of Transfer (EOT0# or EOT1#) Input.")  | Yes  | Yes   | 0                          | <b>0</b>                |
| 16    | DMA Clear Count Mode. When set to 1, if it is in Local memory, byte count in each chaining descriptor is cleared when corresponding DMA transfer completes.<br><b>Note:</b> If the chaining descriptor is in PCI memory, the count is not cleared. (This is the PCI4520/DM7520/DM7540 situation)  | Yes  | Yes   | 0                          | <b>0</b>                |
| 17    | DMA Channel 0 Interrupt Select. Value of 1 routes DMA Channel 0 interrupt to PCI interrupt. Value of 0 routes DMA Channel 0 interrupt to Local Bus interrupt.   | Yes  | Yes   | 0                          | <b>1</b>                |
| 31:18 | Reserved.   | Yes  | No    | 0                          | <b>0.. 0</b>            |

**7.4.2. (DMAPADR0; PCI:84h) DMA Channel 0 PCI Address Register**

| Bit  | Description   | Read | Write | Value after Reset | Value in PCI4520 DM7520 |
|------|---|------|-------|-------------------|-------------------------|
| 31:0 | PCI Address Register. Indicates from where in PCI memory space the DMA transfers (reads or writes) start. | Yes  | Yes   | 0                 | PCI Data Buffer Address |

**7.4.3. (DMALADR0; PCI:88h) DMA Channel 0 Local Address Register**

| Bit  | Description   | Read | Write | Value after Reset | Value in PCI4520 DM7520 |
|------|---|------|-------|-------------------|-------------------------|
| 31:0 | Local Address Register. Indicates from where in Local memory space the DMA transfers (reads or writes) start. | Yes  | Yes   | 0                 | LAS1 + offset           |

**7.4.4. (DMASIZ0; PCI:8Ch) DMA Channel 0 Transfer Size (Bytes) Register**

| Bit   | Description  | Read | Write | Value after Reset | Value in PCI4520 DM7520 |
|-------|--|------|-------|-------------------|-------------------------|
| 22:0  | DMA Transfer Size (Bytes). Indicates number of bytes to transfer during DMA operation. | Yes  | Yes   | 0                 | Byte number             |
| 31:23 | Reserved.  | Yes  | No    | 0                 | 0.. 0                   |

**7.4.5. (DMADPR0; PCI:90h) DMA Channel 0 Descriptor Pointer Register**

| Bit  | Description   | Read | Write | Value after Reset | Value in PCI4520 DM7520 |
|------|---|------|-------|-------------------|-------------------------|
| 0    | Descriptor Location. Value of 1 indicates PCI Address space. Value of 0 indicates Local Address Space.  | Yes  | Yes   | 0                 | 1 (No local memory)     |
| 1    | End of Chain. Value of 1 indicates end of chain. Value of 0 indicates not end of chain descriptor. (Same as Non-chaining Mode.)   | Yes  | Yes   | 0                 | 0 or 1                  |
| 2    | Interrupt after Terminal Count. Value of 1 causes interrupt to be generated after terminal count for this descriptor is reached. Value of 0 disables interrupts from being generated. | Yes  | Yes   | 0                 | 0 or 1                  |
| 3    | Direction of Transfer. Value of 1 indicates transfers from the Local Bus to PCI Bus. Value of 0 indicates transfers from the PCI Bus to Local Bus.                                    | Yes  | Yes   | 0                 | 0 or 1                  |
| 31:4 | Next Descriptor Address. Quad word aligned (bits [3:0] = 0000).   | Yes  | Yes   | 0                 | Address                 |

### 7.4.6. (DMAMODE1; PCI:94h) DMA Channel 1 Mode Register

| Bit       | Description   | Read | Write | After Reset                | Value in PCI4520/7520 |
|-----------|---|------|-------|----------------------------|-----------------------|
| 1:0       | Local Bus Width. Value of 00 indicates bus width of 8 bits. Value of 01 indicates bus width of 16 bits. Value of 10 or 11 indicates bus width of 32 bits.   | Yes  | Yes   | S = 01<br>J = 11<br>C = 11 | <b>01</b>             |
| 5:2       | Internal Wait States (data to data).  | Yes  | Yes   | 0                          | <b>000</b>            |
| 6         | Ready Input Enable. Value of 1 enables Ready input. Value of 0 disables Ready input.  | Yes  | Yes   | 0                          | <b>1</b>              |
| 7         | BTERM# Input Enable. Value of 1 enables BTERM# input. Value of 0 disables BTERM# input. If set to 0, the PCI 9080 bursts four Lword maximum at a time.  | Yes  | Yes   | 0                          | <b>0</b>              |
| 8         | Local Burst Enable. Value of 1 enables bursting. Value of 0 disables local bursting. If burst is disabled, Local Bus performs continuous single cycles for Burst PCI Read/Write cycles.   | Yes  | Yes   | 0                          | <b>1</b>              |
| 9         | Chaining. Value of 1 indicates Chaining mode is enabled. For Chaining mode, DMA source address, destination address and byte count are loaded from memory in PCI address Spaces. Value of 0 indicates Non-chaining mode is enabled.   | Yes  | Yes   | 0                          | <b>1 or 0</b>         |
| 10        | Done Interrupt Enable. Value of 1 enables interrupt when done. Value of 0 disables interrupt when done. If DMA Clear Count mode is enabled, interrupt does not occur until byte count is cleared.   | Yes  | Yes   | 0                          | <b>1 or 0</b>         |
| 11        | Local Addressing Mode. Value of 1 indicates Local Address LA[31:2] to be held constant. Value of 0 indicates Local Address is incremented.  | Yes  | Yes   |                            | <b>1</b>              |
| 12        | Demand Mode. Value of 1 causes DMA controller to operate in Demand mode. In Demand mode, DMA controller transfers data when its DREQ[1:0]# input is asserted. Asserts DACK[1:0]# to indicate current Local Bus transfer is in response to DREQ[1:0]# input. DMA controller transfers Lwords (32 bits) of data. May result in multiple transfers for 8- or 16-bit bus  | Yes  | Yes   | 0                          | <b>1</b>              |
| 13        | Write and Invalidate Mode for DMA Transfers. When set to 1, the PCI 9080 performs Write and Invalidate cycles to PCI Bus. The PCI 9080 supports Write and Invalidate sizes of 8 or 16 Lwords. Size specified in PCI Cache Line Size Register. If size other than 8 or 16 is specified, the PCI 9080 performs Write transfers rather than Write and Invalidate transfers. Transfers must start and end at Cache Line boundaries. | Yes  | Yes   | 0                          | <b>0</b>              |
| 14        | DMA EOT (End of Transfer) Enable. Value of 1 enables EOT[1:0]# input pin. Value of 0 disables EOT[1:0]# input pin. (EOT0# or EOT1# Input.)  | Yes  | Yes   | 0                          | <b>0</b>              |
| 15        | DMA Stop Data Transfer Mode. Value of 0 sends BLAST to terminate DMA transfer. Value of 1 indicates EOT asserted or DREQ[1:0]# de-asserted during Demand mode DMA terminates a DMA transfer. (Refer to Section 3.7.6.1, "End of Transfer (EOT0# or EOT1# Input).")  | Yes  | Yes   | 0                          | <b>0</b>              |
| 16        | DMA Clear Count Mode. When set to 1, if it is in Local memory, byte count in each chaining descriptor is cleared when corresponding DMA transfer completes.<br><b>Note:</b> If the chaining descriptor is in PCI memory, the count is not cleared. (This is the PCI4520/DM7520/DM7540 situation)  | Yes  | Yes   | 0                          | <b>0</b>              |
| 17        | DMA Channel 0 Interrupt Select. Value of 1 routes DMA Channel 0 interrupt to PCI interrupt. Value of 0 routes DMA Channel 0 interrupt to Local Bus interrupt.   | Yes  | Yes   | 0                          | <b>1</b>              |
| 31:<br>18 | Reserved.   | Yes  | No    | 0                          | <b>0.. 0</b>          |

**7.4.7. (DMAPADR1; PCI:98h) DMA Channel 1 PCI Address Register**

| Bit  | Description   | Read | Write | Value after Reset | Value in PCI4520 DM7520 |
|------|---|------|-------|-------------------|-------------------------|
| 31:0 | PCI Address Register. Indicates from where in PCI memory space the DMA transfers (reads or writes) start. | Yes  | Yes   | 0                 | PCI Data Buffer Address |

**7.4.8. (DMALADR1; PCI:9Ch) DMA Channel 1 Local Address Register**

| Bit  | Description   | Read | Write | Value after Reset | Value in PCI4520 DM7520 |
|------|---|------|-------|-------------------|-------------------------|
| 31:0 | Local Address Register. Indicates from where in Local memory space the DMA transfers (reads or writes) start. | Yes  | Yes   | 0                 | 40000000..4000000C      |

**7.4.9. (DMASIZ1; PCI:A0h) DMA Channel 1 Transfer Size (Bytes) Register**

| Bit   | Description  | Read | Write | Value after Reset | Value in PCI4520 DM7520 |
|-------|--|------|-------|-------------------|-------------------------|
| 22:0  | DMA Transfer Size (Bytes). Indicates number of bytes to transfer during DMA operation. | Yes  | Yes   | 0                 | Byte number             |
| 31:23 | Reserved.  | Yes  | No    | 0                 | 0.. 0                   |

**7.4.10. (DMADPR1; PCI:A4h) DMA Channel 0 Descriptor Pointer Register**

| Bit  | Description   | Read | Write | Value after Reset | Value in PCI4520 DM7520 |
|------|---|------|-------|-------------------|-------------------------|
| 0    | Descriptor Location. Value of 1 indicates PCI Address space. Value of 0 indicates Local Address Space.  | Yes  | Yes   | 0                 | 1 (No local memory)     |
| 1    | End of Chain. Value of 1 indicates end of chain. Value of 0 indicates not end of chain descriptor. (Same as Non-chaining Mode.)   | Yes  | Yes   | 0                 | 0 or 1                  |
| 2    | Interrupt after Terminal Count. Value of 1 causes interrupt to be generated after terminal count for this descriptor is reached. Value of 0 disables interrupts from being generated. | Yes  | Yes   | 0                 | 0 or 1                  |
| 3    | Direction of Transfer. Value of 1 indicates transfers from the Local Bus to PCI Bus. Value of 0 indicates transfers from the PCI Bus to Local Bus.                                    | Yes  | Yes   | 0                 | 0 or 1                  |
| 31:4 | Next Descriptor Address. Quad word aligned (bits [3:0] = 0000).   | Yes  | Yes   | 0                 | Address                 |

**7.4.11. (DMACSR0; PCI:A8h) DMA Channel 0 Command/Status Register**

| Bit | Description  | Read | Write   | Value after Reset | Value in PCI4520 DM7520 |
|-----|--|------|---------|-------------------|-------------------------|
| 0   | Channel 0 Enable. Value of 1 enables channel to transfer data. Value of 0 disables channel from starting DMA transfer and if in process of transferring data suspend transfer (pause). | Yes  | Yes     | 0                 | 0 or 1                  |
| 1   | Channel 0 Start. Value of 1 causes channel to start transferring data if channel is enabled.   | Yes  | Yes/Set | 0                 | 0 or 1                  |
| 2   | Channel 0 Abort. Value of 1 causes channel to abort current transfer. Channel Enable bit must be cleared. Channel Complete bit is set when abort is complete.                          | Yes  | Yes/Set | 0                 | 0 or 1                  |
| 3   | Clear Interrupt. Writing 1 to this bit clears Channel 0 interrupts.  | Yes  | Yes/Clr | 0                 | 0 or 1                  |
| 4   | Channel 0 Done. Value of 1 indicates channel's transfer is complete. Value of 0 indicates channel's transfer is not complete.  | Yes  | No      | 1                 | -                       |
| 7:5 | Reserved.  | Yes  | No      | 0                 | -                       |

**7.4.12. (DMACSR1; PCI:A9h) DMA Channel 1 Command/Status Register**

| Bit | Description  | Read | Write   | Value after Reset | Value in PCI4520 DM7520 |
|-----|--|------|---------|-------------------|-------------------------|
| 0   | Channel 1 Enable. Value of 1 enables channel to transfer data. Value of 0 disables channel from starting DMA transfer and if in process of transferring data suspend transfer (Pause). | Yes  | Yes     | 0                 | 0 or 1                  |
| 1   | Channel 1 Start. Value of 1 causes channel to start transferring data if channel is enabled.   | Yes  | Yes/Set | 0                 | 0 or 1                  |
| 2   | Channel 1 Abort. Value of 1 causes channel to abort current transfer. Channel Enable bit must be cleared. Channel Complete bit is set when abort is complete.                          | Yes  | Yes/Set | 0                 | 0 or 1                  |
| 3   | Clear Interrupt. Writing 1 to this bit clears Channel 0 interrupts.  | Yes  | Yes/Clr | 0                 | 0 or 1                  |
| 4   | Channel 1 Done. Value of 1 indicates channel's transfer is complete. Value of 0 indicates channel's transfer is not complete.  | Yes  | No      | 1                 | -                       |
| 7:5 | Reserved.  | Yes  | No      | 0                 | -                       |

### 7.4.13. (DMAARB; PCI:ACh) DMA Arbitration Register

Same as Mode/Arbitration register (MARBR) at address PCI:08h.

### 7.4.14. (DMATHR; PCI:B0h) DMA Threshold Register

| Bit   | Description   | Read | Write | Value after Reset |
|-------|---|------|-------|-------------------|
| 3:0   | 0 DMA Channel 0 PCI-to-Local Almost Full (C0PLAF). Number of full entries (divided by two, minus one) in the FIFO before requesting Local Bus for writes. (C0PLAF+1) + (C0PLAE+1) should be £ FIFO Depth of 32. | Yes  | Yes   | 0                 |
| 7:4   | DMA Channel 0 Local-to-PCI Almost Empty (C0LPAE). Number of empty entries (divided by two, minus one) in the FIFO before requesting Local Bus for reads.(C0LPAF+1) + (C0LPAE+1) should be £ FIFO depth of 32.   | Yes  | Yes   | 0                 |
| 11:8  | DMA Channel 0 Local-to-PCI Almost Full (C0LPAF). Number of full entries (divided by two, minus one) in the FIFO before requesting PCI Bus for writes.   | Yes  | Yes   | 0                 |
| 15:12 | DMA Channel 0 PCI-to-Local Almost Empty (C0PLAE). Number of empty entries (divided by two, minus one) in the FIFO before requesting PCI Bus for reads.  | Yes  | Yes   | 0                 |
| 19:16 | DMA Channel 1 PCI-to-Local Almost Full (C1PLAF). Number of full entries(minus one) in the FIFO before requesting Local Bus for writes. (C1PLAF+1) + (C1PLAE+1) should be £ FIFO depth of 16.                    | Yes  | Yes   | 0                 |
| 23:20 | DMA Channel 1 Local-to-PCI Almost Empty (C1LPAE). Number of empty entries (minus one) in the FIFO before requesting Local Bus for reads. (C1PLAF) + (C1PLAE) should be £ FIFO depth of 16.                      | Yes  | Yes   | 0                 |
| 27:24 | DMA Channel 1 Local-to-PCI Almost Full (C1LPAF). Number of full entries (minus one) in the FIFO before requesting PCI Bus for writes.   | Yes  | Yes   | 0                 |
| 31:28 | DMA Channel 1 PCI-to-Local Almost Empty (C1PLAE). Number of empty entries (minus one) in the FIFO before requesting PCI Bus for reads.  | Yes  | Yes   | 0                 |

**Note:** If the number of entries needed is x, then the value is one less than half the number of entries (DMA Channel 0 only).

## 8. Interrupts

This chapter explains the possible interrupt sources and the priority Interrupt Controller of the board.

The PCI4520/DM7520/DM7540 uses the INTA# interrupt line which are assigned to one of the free IRQ channels by the PCI BIOS.

Because of the several interrupt sources on the board a Priority Interrupt Controller was built on the board. This controller assures even usage all of the interrupt sources on the board.

### 8.1. The Overall Interrupt Structure of PCI4520/DM7520/DM7540

#### 8.1.1. The Interrupt Sources of PCI4520/DM7520

The PCI4520/DM7520/DM7540 PCI interrupt (ITA#) can be generated one of the following:

- The On-board Priority Interrupt Controller
- DMA Ch 0/Ch 1 Done
- DMA Ch 0/Ch 1 Terminal Count reached

INTA#, or individual sources of an interrupt, can be enabled or disabled with the PCI 9080 Interrupt Control/Status register (INTCSR). This register also provides interrupt status for each interrupt source. The PCI 9080 PCI Bus interrupt is level output. Disabling an Interrupt Enable bit or clearing the cause(s) of the interrupt can clear an interrupt.

#### The On Board Priority Interrupt Controller

The On-board Priority Interrupt controller can assert the Local Bus input pin. Asserting Local Bus input pin LINTi# can generate a PCI Bus interrupt. PCI Host processor can read the PCI 9080 Interrupt Control/Status register to determine that an interrupt is pending due to the LINTi# pin being asserted. The interrupt remains asserted as long as the LINTi# pin is asserted and the Local interrupt input is enabled. Clearing the Interrupt Request Register (LAS0+034h) can be taken by the PCI Host processor to cause the Local Bus to release LINTi#.

#### DMA Channel 0/1 Interrupts

A DMA channel can generate a PCI interrupt when done (transfer complete) or after a transfer is complete for a descriptor in Chaining mode. A bit in the DMA mode register determines whether to generate a PCI or Local interrupt. (The Local interrupt does not make sense because there are no Local Processor) The PCI processor can then read the PCI 9080 Interrupt Control/Status register (INTCSR) to determine whether a DMA channel interrupt is pending. A Done Status Bit in the Control/Status register can be used to determine whether the interrupt is

- a done interrupt
- the result of a transfer for a descriptor in a chain that is not yet complete

The mode register of a channel enables a Done Interrupt. In Chaining mode, a bit in the Next Descriptor Pointer register of the channel specifies whether to generate an interrupt at the end of the transfer for the current descriptor. A DMA channel interrupt is cleared by writing a 1 to the Clear Interrupt bit in the DMA Command/Status register (DMACSR0[3] and DMACSR1[3]).

### 8.1.2. The Interrupt Registers of PCI4520/DM7520

The PCI4520/DM7520/DM7540 has two Interrupt register groups. The first is inside the PCI9080 Interface chip the other is inside the Control Logic of the board.

The PCI9080 Interrupt Control/Status Register is at the PCI:68h address: INTCSR:

(INTCSR; PCI:68h) Interrupt Control/Status Register:

| Bit | Description   | Read | Write | Value after Reset | Value in PCI4520 /DM7520 |
|-----|---|------|-------|-------------------|--------------------------|
| 0   | Enable Local Bus LSERR#. Value of 1 enables the PCI 9080 to assert LSERR# interrupt output when PCI Bus Target Abort or Master Abort Status bit is set in PCI Status Configuration register.  | Yes  | Yes   | 0                 | 0                        |
| 1   | Enable Local Bus LSERR# when PCI parity error occurs during a PCI 9080 Master Transfer or a PCI 9080 Slave access or an Outbound Free List FIFO Overflow Init.  | Yes  | Yes   | 0                 | 0                        |
| 2   | Generate PCI Bus SERR# When this bit is set to 0, writing 1 generates a PCI bus SERR#.  | Yes  | Yes   | 0                 | 0                        |
| 3   | Mailbox Interrupt Enable. Value of 1 enables a Local interrupt to be generated when PCI Bus writes to Mailbox registers 0 through 3. To clear a Local interrupt, the Local Master must read the Mailbox. Used in conjunction with Local interrupt enable. | Yes  | Yes   | 0                 | 0                        |
| 7:4 | Reserved.   | Yes  | No    | 0                 | 0                        |
| 8   | PCI Interrupt Enable. Value of 1 enables PCI interrupts.  | Yes  | Yes   | 1                 | 1                        |
| 9   | PCI Doorbell Interrupt Enable. Value of 1 enables doorbell interrupts. Used in conjunction with PCI interrupt enable. Clearing doorbell interrupt bits that caused interrupt also clears interrupt.   | Yes  | Yes   | 0                 | 0                        |
| 10  | PCI Abort Interrupt Enable. Value of 1 enables Master abort or Master detect of Target abort to generate PCI interrupt. Used in conjunction with PCI interrupt enable. Clearing abort status bits also clears PCI interrupt.                              | Yes  | Yes   | 0                 | 0                        |
| 11  | PCI Local Interrupt Enable. Value of 1 enables Local interrupt input to generate a PCI interrupt. Use in conjunction with PCI interrupt enable. Clearing the Local Bus cause of interrupt also clears interrupt.  | Yes  | Yes   | 0                 | 1                        |
| 12  | Retry Abort Enable. Value of 1 enables the PCI 9080 to treat 256 Master consecutive retries to a Target as a Target Abort. Value of 0 enables the PCI 9080 to attempt Master Retries indefinitely.<br><b>Note:</b> For iagnostic purposes only.           | Yes  | Yes   | 0                 | 0                        |
| 13  | Value of 1 indicates PCI doorbell interrupt is active.  | Yes  | Yes   | 0                 | 0                        |
| 14  | Value of 1 indicates PCI abort interrupt is active  | Yes  | Yes   | 0                 | 0                        |
| 15  | Value of 1 indicates Local interrupt is active (LINTi#).  | Yes  | Yes   | 0                 | 0                        |
| 16  | Local Interrupt Output Enable. Value of 1 enables Local interrupt output.   | Yes  | Yes   | 1                 | 0                        |

| Bit | Description  | Read | Write | Value after Reset | Value in PCI4520 /DM7520 |
|-----|--|------|-------|-------------------|--------------------------|
| 17  | Local Doorbell Interrupt Enable. Value of 1 enables doorbell interrupts. Used in conjunction with Local interrupt enable. Clearing local doorbell interrupt bits that caused interrupt also clears interrupt.                          | Yes  | Yes   | 0                 | 0                        |
| 18  | Local DMA Channel 0 Interrupt Enable. Value of 1 enables DMA Channel 0 interrupts. Used in conjunction with Local interrupt enable. Clearing DMA status bits lso clears interrupt.   | Yes  | Yes   | 0                 | 0 or 1                   |
| 19  | Local DMA Channel 1 Interrupt Enable. Value of 1 enables DMA Channel 1 interrupts. Used in conjunction with Local interrupt enable. Clearing DMA status bits also clears interrupt.  | Yes  | Yes   | 0                 | 0                        |
| 20  | Value of 1 indicates local doorbell interrupt is active.   | Yes  | No    | 0                 | 0                        |
| 21  | Value of 1 indicates DMA Ch 0 interrupt is active.   | Yes  | No    | 0                 | 0                        |
| 22  | Value of 1 indicates DMA Ch 1 interrupt is active.   | Yes  | No    | 0                 | 0                        |
| 23  | Value of 1 indicates BIST interrupt is active. Writing 1 to bit 6 of PCI Configuration BIST Register generates BIST (Built-In Self-Test) interrupt. Clearing bit 6 clears interrupt. For description of self-test, refer to PCI BISTR. | Yes  | No    | 0                 | 0                        |
| 24  | Value of 0 indicates Direct Master was Bus Master during a Master or Target abort. (Not valid until abort occurs.)   | Yes  | No    | 1                 | 1                        |
| 25  | Value of 0 indicates DMA CH 0 was Bus Master during a Master or Target abort. (Not valid until abort occurs.)  | Yes  | No    | 1                 | 1                        |
| 26  | Value of 0 indicates DMA CH 1 was Bus Master during a Master or Target abort. (Not valid until abort occurs.)  | Yes  | No    | 1                 | 1                        |
| 27  | Value of 0 indicates Target Abort was generated by the PCI 9080 after 256 consecutive Master retries to Target. (Not valid until abort occurs.)  | Yes  | No    | 1                 | 1                        |
| 28  | Value of 1 indicates PCI wrote data to MailBox #0. Enabled only if MBOXINTENB is enabled (bit 3 high).   | Yes  | No    | 0                 | N/A                      |
| 29  | Value of 1 indicates PCI wrote data to MailBox #1. Enabled only if MBOXINTENB is enabled (bit 3 high).   | Yes  | No    | 0                 | N/A                      |
| 30  | Value of 1 indicates PCI wrote data to MailBox #2. Enabled only if MBOXINTENB is enabled (bit 3 high).   | Yes  | No    | 0                 | N/A                      |
| 31  | Value of 1 indicates PCI wrote data to MailBox #3. Enabled only if MBOXINTENB is enabled (bit 3 high).   | Yes  | No    | 0                 | N/A                      |

The other group of interrupt registers are the on-board priority interrupt controller registers of the board (LAS0 + 030h.. 038h).

## 8.2. The Operation of On-board Priority Interrupt Controller

After power-up all of the interrupt sources are disabled on the board. In this state place your Interrupt Service Routine which will be used in the case of an interrupt generated by the board.

The initialization process of the controller is:

- Set all bits to 1 in the Interrupt Clear Mask Register.
- Read a dummy data from Clear Interrupt set by Clear Mask address. These two steps means that all Interrupt requests are cleared

- Write Interrupt mask register. If an interrupt source must be used, that position in the register must be set to 1.

After this initialization process the Interrupt Controller receives the interrupt requests, and according to their priority order transmits them to the PC. One time one request.

In the Interrupt service routine you must identify the current interrupt source reading by (INTCSR; PCI:68h) Interrupt Control/Status Register of PCI9080, and then the Interrupt Status Register of on-board Priority Interrupt Controller. The INTCSR description can be found in the Chapter 8.1.2. In the on-board priority register there is a position where the bit is high, signaling the active interrupt source from the priority interrupt sources. All of the other bits are zero. Identifying the source, it can be serviced. After servicing, the request must be cleared by accessing the Interrupt clear mask and the Clear Interrupt set by Clear Mask registers.

In the normal operation, the next interrupt request comes later than clearing of the previous. If this is override, it can be detected by the Interrupt Overrun register. If the interrupts serviced in time all bits are zeros in the overrun register. If a new interrupt request comes before the previous has been serviced and the request is cleared, the appropriate overrun bit goes into high signaling the faulty - too slow interrupt service - operation.

### **8.3. Advanced Digital Interrupts**

The bit programmable digital I/O circuitry supports two Advanced Digital Interrupt modes, event mode or match mode. These modes are used to monitor digital input lines (P0..7) for state changes. The mode is selected at LAS2+13h, D3 and enabled at LAS2+13h, D4.

#### **8.3.1. Event Mode**

When enabled, this mode samples the Port 0 input lines at a specified clock rate (using the 8 MHz system clock or a programmable clock in User TC Counter 1), looking for a change in state in any one of the eight bits. When a change of state occurs, an interrupt is generated and the input pattern is latched into the Compare Register. You can read the contents of this register at LAS2+12h to see which bit caused the interrupt to occur. Bits can be masked and their state changes ignored by programming the Mask Register with the mask at LAS2+12h.

#### **8.3.2. Match Mode**

When enabled, this mode samples the Port 0 input lines at a specified clock rate (using the 8 MHz system clock or a programmable clock in User TC Counter 1) and compares all input states to the value programmed in the Compare Register at LAS2+12. When the states of all of the lines match the value in the Compare Register, an interrupt is generated. Bits can be masked and their states ignored by programming the Mask Register with the mask at LAS2+12h.

#### **8.3.3. Sampling Digital Lines for Change of State**

In the Advanced Digital Interrupt modes, the digital lines are sampled at a rate set by the 8 MHz system clock or the clock programmed in User TC Counter 1. With each clock pulse, the digital circuitry looks at the state of the next Port 0 bits. To provide noise rejection and prevent erroneous interrupt generation because of noise spikes on the digital lines, a change in the state of any bit must be seen for two edges of a clock pulse to be recognized by the circuit.

## 9. Timer/Counters

The Timer/Counter section contains internal TCs in the Control EPLD and an 8254 programmable interval timers (U43) for User Timer Counter.

### 9.1. The internal Timer Timer/Counters

The internal Timer Counters works similar to the 8254 in rate mode. The PCI4520/DM7520/DM7540 has 8 internal timer counter:

1. Pacer Clock - 24bit - Clock Signal is 8MHz
2. Burst Clock - 10bit - Clock Signal is 8MHz
3. A/D Sample counter - 10 bit - Clock signal can be programmed
4. D/A1 Update counter - 10 bit - Clock signal is D/A1 update
5. D/A2 Update counter - 10 bit - Clock signal is D/A2 update
6. Delay Counter - 16 bit - Clock signal can be programmed
7. About Counter - 16 bit - Clock signal can be programmed
8. D/A Clock – 16 (24bit-DM7520) bit - Clock Signal is 8MHz

### 9.2. User Timer Timer/Counters

The 8254 at U43 is the User TC. All three counters on this chip are available for user functions. For details on the programming modes of the 8254, see the data sheet in Appendix.

Each timer/counter has two inputs, CLK in and GATE in, and one output, timer/counter OUT. They can be programmed as binary or BCD down counters by writing the appropriate data to the command word, as described in the I/O map discussion in Chapter 4. See Figure 9.2.1. The sources of the user TC clocks and gates can be programmed by User Timer address area is the LAS0+1A0.. 1B4. It is important, that the registers of the Timer Counter can be accessed by byte wide instructions. the 16 bit wide word must be created from the bytes.

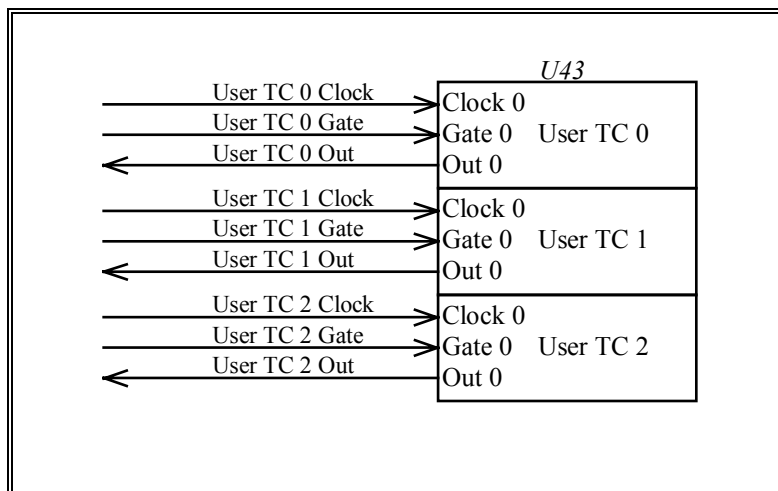

Figure 9.2.1.

The timers can be programmed to operate in one of six modes, depending on your application. The following paragraphs briefly describe each mode.

**Mode 0, Event Counter (Interrupt on Terminal Count).** This mode is typically used for event counting. While the timer/counter counts down, the output is low, and when the count is complete, it goes high. The output stays high until a new Mode 0 control word is written to the timer/counter.

**Mode 1, Hardware-Retriggerable One-Shot.** The output is initially high and goes low on the clock pulse following a trigger to begin the one-shot pulse. The output remains low until the count reaches 0, and then goes high and remains high until the clock pulse after the next trigger.

**Mode 2, Rate Generator.** This mode functions like a divide-by-N counter and is typically used to generate a real-time clock interrupt. The output is initially high, and when the count decrements to 1, the output goes low for one clock pulse. The output then goes high again, the timer/counter reloads the initial count, and the process is repeated. This sequence continues indefinitely.

**Mode 3, Square Wave Mode.** Similar to Mode 2 except for the duty cycle output, this mode is typically used for baud rate generation. The output is initially high, and when the count decrements to one-half its initial count, the output goes low for the remainder of the count. The timer/counter reloads and the output goes high again. This process repeats indefinitely.

**Mode 4, Software-Triggered Strobe.** The output is initially high. When the initial count expires, the output goes low for one clock pulse and then goes high again. Counting is “triggered” by writing the initial count.

**Mode 5, Hardware Triggered Strobe (Retriggerable).** The output is initially high. Counting is triggered by the rising edge of the gate input. When the initial count has expired, the output goes low for one clock pulse and then goes high again.

## 10. Digital I/O

The PCI4520/DM7520/DM7540 has several digital circuitry to receive and transmit digital data from, or to the external digital world. This chapters describes only the 31.. 46 pins of External I/O connector. These 16 Digital Input/Output lines are multifunctions and assures a flexible connection with the digital world.

The connections of odd numbered pin is shown in the Figure 10.1. These lines are monitored by the high-speed digital input circuitry, and the least significant three bits of the A/D FIFO as data markers, therefore these lines can be read or driven by the Port 0 of Digital I/O Chip.

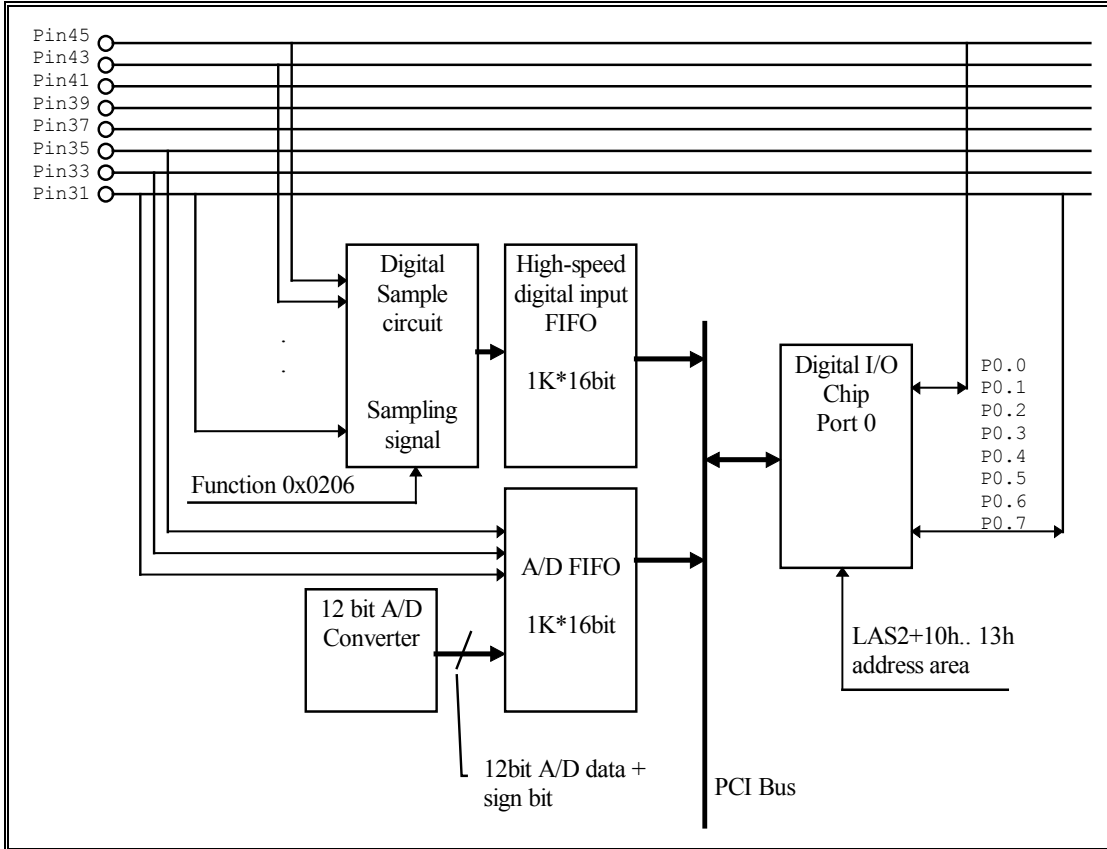

Figure 10.1.

Fig

The connections of even numbered pin is shown in the Figure 10.2. These lines can be driven by the digital part of the CGT, therefore these lines can be read or driven by the Port 1 of Digital I/O Chip.

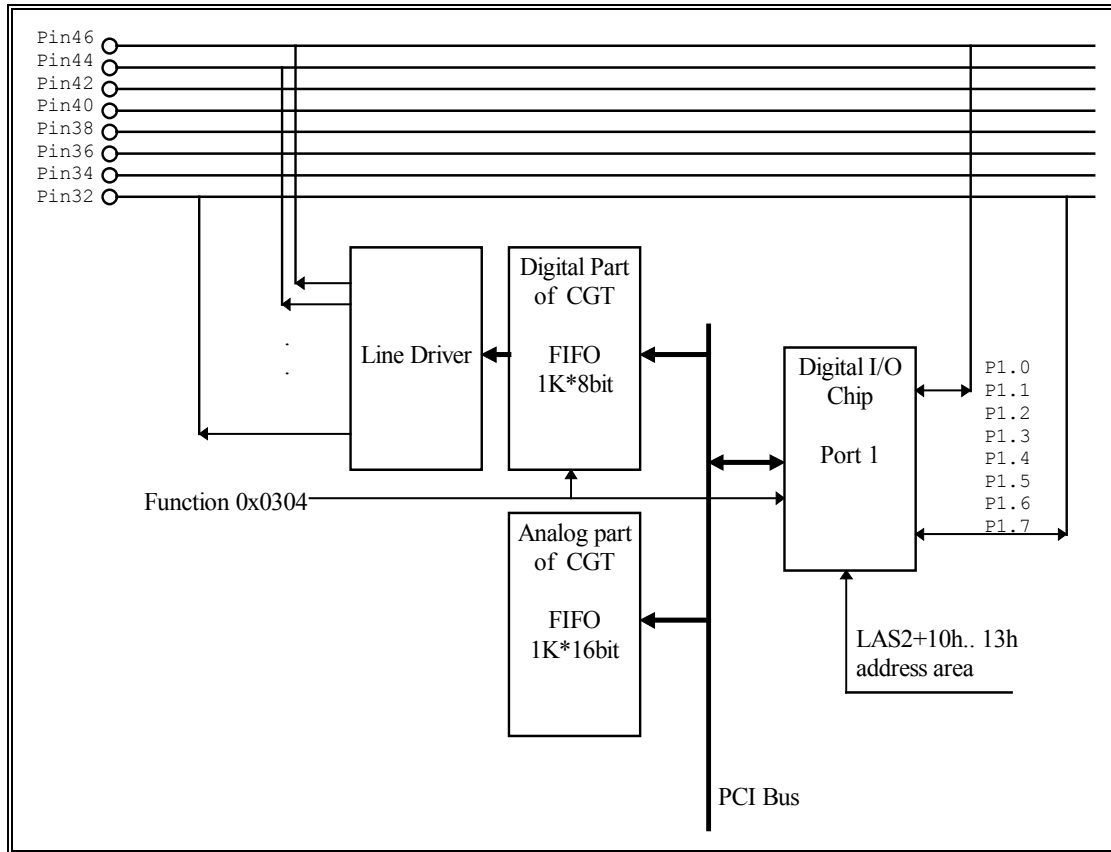

Figure 10.2.

## 10.1. The Digital I/O Chip

The PCI4520/DM7520/DM7540 has 16 buffered TTL/CMOS digital I/O lines available for digital control applications. These lines are grouped in two 8-bit ports. The sixteen bits in Port 0 can be independently programmed as input or output. Port 1 can be programmed as 8-bit input or output ports. These lines are grouped in digital I/O chip with sixteen lines. The Digital I/O chip is addressed at LAS0 + 070h.. LAS0 + 07Fh.

All digital inputs are pulled up to +5V by 10kOhm resistors. All digital outputs are terminated by series 100Ohm resistors.

### 10.1.1 Port 0, Bit Programmable Digital I/O

The eight Port 0 digital lines are individually set for input or output by writing to the Direction Register at LAS0 + 078h. The input lines are read and the output lines are written at LAS0 + 070h.

### 10.1.2. Advanced Digital Interrupts: Mask and Compare Registers

The Port 0 bits support two Advanced Digital Interrupt modes. An interrupt can be generated when the data read at the port matches the value loaded into the Compare Register. This is called a match interrupt. Or, an interrupt can be generated whenever any bit changes state. This is an event interrupt. For either interrupt, bits can be masked by setting the corresponding bit in the Mask Register high. In a digital interrupt mode, this masks out selected bits when monitoring the bit pattern for a match or event. In normal

operation where the Advanced Digital Interrupt mode is not activated, the Mask Register can be used to preserve a bit's state, regardless of the digital data written to Port 0.

When using event interrupts, you can determine which bit caused an event interrupt to occur by reading the contents latched into the Compare Register.

### **10.1.3. Port 1, Port Programmable Digital I/O**

The direction of the eight bit Port 1 digital lines is programmed at LAS0 + 07Ch, bit 2. These lines are configured as all inputs or all outputs, with their states read and written at LAS0 + 074h.

### **10.1.4. Resetting the Digital Circuitry**

When a digital chip clear (LAS0 + 07Ch bits 1 and 0 = 00 followed by a write to LAS0 + 078h), Software Reset of the board (Function 0x000F), all of the digital I/O lines are set up as inputs.

### **10.1.5. Strobing Data into Port 0**

When not in an Advanced Digital Interrupt mode, external data can be strobed into Port 0 by connecting a trigger pulse through the External Pacer Clock pin at the External I/O Connector. This data can be read from the Compare Register at LAS0 + 078h.

## **10.2. High-Speed Digital Input**

As you can see in the Figure 9.1. the Pin 31.. 45 digital pins of external I/O connector can be sampled by high -speed digital input circuitry. The sampling signal can be selected by the Function 0x0206. Samples are written automatically into the high-speed digital input FIFO. The status bits of FIFO can be monitored at the address LAS0+8h.

If you want to get an interrupt at a required number of samples in the FIFO, use User Timer Counter 1 as high speed digital input sample counter. Select the high-speed digital input sampling signal as clock of user TC1 by the Function 0x0702.

All digital inputs are pulled up to +5V by 10kOhm resistors.

## **10.3. Digital Input Data Markers**

As you can see in the Figure 10.1. the digital pin 31, 33, 35 can be sampled nearly simultaneously with the analog input signal by the A/D FIFO. The delay time between the analog input sampling and the digital input sampling is app. 800 ns. If you want to sample the digital lines with the analog lines really simultaneously, use the high-speed digital input with A/D Conversion Signal as sampling signal of high-speed digital input.

All digital inputs are pulled up to +5V by 10kOhm resistors.

## 11. Calibration

This chapter tells you how to calibrate the PCI4520/DM7520/DM7540 using the CAL5420 program included in the software package and the trimpots on the board. These trimpots calibrate the A/D converter gain and offset, and the D/A outputs.

This chapter tells you how to calibrate the A/D converter gain and offset, and the D/A output multiplier. The offset and full-scale performance of the board's A/D and D/A converters is factory-calibrated. Any time you suspect inaccurate readings, you can check the accuracy of your conversions using the procedure below, and make adjustments as necessary. Using the CAL5420 program is a convenient way to monitor conversions while you calibrate the board.

Calibration is done with the board installed in your system. You can access the trimpots at the top edge of the board. Power up the system and let the board circuitry stabilize for 15 minutes before you start calibrating.

### 11.1. Required Equipment

The following equipment is required for calibration:

- Precision Voltage Source: -10 to +10 volts
- Digital Voltmeter: 5-1/2 digits
- Small Screwdriver (for trimpot adjustment)

While not required, the CAL5420 program (included software) is helpful when performing calibrations.

### 11.2. A/D Calibration

Two procedures are used to calibrate the A/D converter for all input voltage ranges. The first procedure calibrates the converter for the bipolar ranges ( $\pm 5$ ,  $\pm 10$  volts), and the second procedure calibrates the unipolar range (0 to +10 volts). Table 12-1 shows the ideal input voltage for each bit weight for the bipolar ranges, and Table 12-2 shows the ideal voltage for each bit weight for the unipolar range.

#### 11.2.1. Bipolar Calibration

##### **Bipolar Range Adjustments: -5 to +5 Volts**

Two adjustments are made to calibrate the A/D converter for the bipolar range of -5 to +5 volts. One is the offset adjustment, and the other is the full scale, or gain, adjustment. Trimpot TR4 is used to make the offset adjustment, and trimpot TR5 is used for gain adjustment. Before making these adjustments, make sure that the board is programmed for a range of  $\pm 5$  volts.

Use analog input channel 1 and set it for a gain of 1 while calibrating the board. Connect your precision voltage source to channel 1. Set the voltage source to -1.22070 millivolts, start a conversion, and read the resulting data. Adjust trimpot TR4 until the reading flickers between the values listed in the table below. Next, set the voltage to -4.99878 volts, and repeat the procedure, this time adjusting TR5 until the data flickers between the values in the table.

| Data Values for Calibrating Bipolar 10 Volt Range (-5 to +5 volts) |  |      |      |   |      |      |
|--|--|------|------|---|------|------|
|  | Offset (TR4)<br>Input Voltage = -1.22 mV |      |      | Converter Gain (TR5)<br>Input Voltage = -4.99878V |      |      |
| <b>A/D Converted Data</b>  | 0000                                     | 0000 | 0000 | 1000  | 0000 | 0000 |
|  | 1111                                     | 1111 | 1111 | 1000  | 0000 | 0001 |

**Bipolar Range Adjustments: -10 to +10 Volts**

To adjust the bipolar 20-volt range (-10 to +10 volts), program the board for ± 10 volt input range. Then, set the input voltage to +5.0000 volts and adjust TR2 until the output matches the data in the table below.

| Data Value for Calibrating Bipolar 20 Volt Range (-10 to +10 volts) |                                 |      |      |
|---|---------------------------------|------|------|
|   | TR2<br>Input Voltage = +5.0000V |      |      |
| <b>A/D Converted Data</b>   | 0100                            | 0000 | 0000 |

Below is a table listing the ideal input voltage for each bit weight for the bipolar ranges.

| Table 12-1 A/D Converter Bit Weights, Bipolar |                |                                  |                  |
|---|----------------|----------------------------------|------------------|
| SIGN  | A/D Bit Weight | Ideal Input Voltage (millivolts) |                  |
|   |                | -5 to +5 Volts                   | -10 to +10 Volts |
| 1   | 1111 1111 1111 | -2.44                            | -4.88            |
| 1   | 1000 0000 0000 | -5000.00                         | -10000.00        |
| 0   | 0100 0000 0000 | +2500.00                         | +5000.00         |
| 0   | 0010 0000 0000 | +1250.00                         | +2500.00         |
| 0   | 0001 0000 0000 | +625.00                          | +1250.00         |
| 0   | 0000 1000 0000 | +312.50                          | +625.00          |
| 0   | 0000 0100 0000 | +156.25                          | +312.50          |
| 0   | 0000 0010 0000 | +78.13                           | +156.25          |
| 0   | 0000 0001 0000 | +39.06                           | +78.13           |
| 0   | 0000 0000 1000 | +19.53                           | +39.06           |
| 0   | 0000 0000 0100 | +9.77                            | +19.53           |
| 0   | 0000 0000 0010 | +4.88                            | +9.77            |
| 0   | 0000 0000 0001 | +2.44                            | +4.88            |
| 0   | 0000 0000 0000 | 0.00                             | 0.00             |

### 11.2.3. Unipolar Calibration

One adjustment is made to calibrate the A/D converter for the unipolar range of 0 to +10 volts. Trimpot TR6 is used to make the offset adjustment. This calibration procedure is performed with the module programmed for a 0 to +10 volt input range. Before making these adjustments, make sure that the module is programmed properly and has been calibrated for the bipolar ranges.

Use analog input channel 1 and set it for a gain of 1 while calibrating the board. Connect your precision voltage source to channel 1. Set the voltage source to +1.22070 millivolts, start a conversion, and read the resulting data. Adjust trimpot TR6 until the data flickers between the values listed in the table below.

| Data Values for Calibrating Unipolar 10 Volt Range<br>(0 to +10 volts) |   |
|--|---|
|  | Offset (TR6)<br>Input Voltage = +1.22070 mV |
| A/D Converted Data   | 0000 0000 0000                              |
|  | 0000 0000 0001                              |

Below is a table listing the ideal input voltage for each bit weight for the unipolar range.

| Table 12-2 A/D Converter Bit Weights,<br>Unipolar |                |                                  |
|---|----------------|----------------------------------|
| SIGN  | A/D Bit Weight | Ideal Input Voltage (millivolts) |
|   |                | 0 to +10 Volts                   |
| 0   | 1111 1111 1111 | +9997.6                          |
| 0   | 1000 0000 0000 | +5000.0                          |
| 0   | 0100 0000 0000 | +2500.0                          |
| 0   | 0010 0000 0000 | +1250.0                          |
| 0   | 0001 0000 0000 | +625.00                          |
| 0   | 0000 1000 0000 | +312.50                          |
| 0   | 0000 0100 0000 | +156.25                          |
| 0   | 0000 0010 0000 | +78.125                          |
| 0   | 0000 0001 0000 | +39.063                          |
| 0   | 0000 0000 1000 | +19.531                          |
| 0   | 0000 0000 0100 | +9.7656                          |
| 0   | 0000 0000 0010 | +4.8828                          |
| 0   | 0000 0000 0001 | +2.4414                          |
| 0   | 0000 0000 0000 | 0                                |

### 11.2.4. Gain Adjustment

Should you find it necessary to check any of the programmable gain settings, the following table will show the proper trimpot to adjust.

| <b>Trim pots for Calibrating Gains</b> |                |
|--|----------------|
| <b>Gain</b>                            | <b>Trimpot</b> |
| x2                                     | TR7            |
| x4                                     | TR8            |
| x8                                     | TR9            |
| x16                                    | TR10           |
| x32                                    | TR11           |
| x64                                    | TR12           |
| x128                                   | TR13           |

### 11.3. D/A Calibration

The D/A circuit requires no calibration for the 0 to +5 and  $\pm 5$  volts ranges. The following paragraph describes the calibration procedure for the 0 to +10 and  $\pm 10$  volt ranges.

To calibrate for the 0 to +10 and  $\pm 10$  volt ranges, program the DAC outputs for a 0 to +10 volt range. Now program the D/A outputs with a digital value of 2048. The ideal D/A output for a code of 2048 is +5.000 volts. Connect a voltmeter to the D/A outputs and adjust TR14 for D/A1 and TR15 for D/A2 until 5.000 volts is read on the meter.

The following tables show the ideal output voltage per bit weight for unipolar,

| Unipolar<br>D/A Bit Weight | Ideal Output Voltage (millivolts) |                |
|----------------------------|-----------------------------------|----------------|
|                            | 0 to +5 Volts                     | 0 to +10 Volts |
| 4095                       | +4998.78                          | +9997.56       |
| 2048                       | +2500.00                          | +5000.00       |
| 1024                       | +1250.00                          | +2500.00       |
| 512                        | +625.00                           | +1250.00       |
| 256                        | +312.50                           | +625.00        |
| 128                        | +156.25                           | +312.50        |
| 64                         | +78.13                            | +156.25        |
| 32                         | +39.06                            | +78.13         |
| 16                         | +19.53                            | +39.06         |
| 8                          | +9.77                             | +19.53         |
| 4                          | +4.88                             | +9.77          |
| 2                          | +2.44                             | +4.88          |
| 1                          | +1.22                             | +2.44          |
| 0                          | 0.00                              | 0.00           |

and bipolar ranges.

| Bipolar<br>D/A Bit Weight | Ideal Output Voltage (millivolts) |                  |
|---------------------------|-----------------------------------|------------------|
|                           | -5 to +5 Volts                    | -10 to +10 Volts |
| 2047                      | +4997.56                          | +9995.12         |
| 1024                      | +2500.00                          | +5000.00         |
| 512                       | +1250.00                          | +2500.00         |
| 256                       | +625.00                           | +1250.00         |
| 128                       | +312.50                           | +625.00          |
| 64                        | +156.25                           | +312.50          |
| 32                        | +78.13                            | +156.25          |
| 16                        | +39.06                            | +78.13           |
| 8                         | +19.53                            | +39.06           |
| 4                         | +9.77                             | +19.53           |
| 2                         | +4.88                             | +9.77            |
| 1                         | +2.44                             | +4.88            |
| 0                         | 0.00                              | 0.00             |
| -1                        | -2.44                             | -4.88            |
| -2                        | -4.88                             | -9.77            |
| -4                        | -9.77                             | -19.53           |
| -8                        | -19.53                            | -39.06           |
| -16                       | -39.06                            | -78.13           |
| -32                       | -78.13                            | -156.25          |
| -64                       | -156.25                           | -312.50          |
| -128                      | -312.50                           | -625.00          |
| -256                      | -625.00                           | -1250.00         |
| -512                      | -1250.00                          | -2500.00         |
| -1024                     | -2500.00                          | -5000.00         |
| -2048                     | -5000.00                          | -10000.00        |

## 12. Specifications

Typical @ 25 C.

### 12.1. Computer Interface

IBM PC/AT – PC/104plus 5V/3V -Universal 32bit PCI Busmaster or target only device. Two memory mapped address area for configuration, mode control, data transfer and timer-counter, digital I/O area. The data transfer area is burst accessed for fast data transfer. The onboard two DMA controllers can generate burst cycles. The maximum data transfer rate in burst mode is 16Msample/s

### 12.2. Analog Input circuitry

Up to 8 Differential 8 SE with dedicate ground, 16 SE inputs Ground or non ground referenced, software selectable

|                                  |                             |
|----------------------------------|-----------------------------|
| Input impedance, each channel    | >10 MOhm                    |
| Gains, Software selectable       | 1, 2, 4, 8, 16, 32, 64, 128 |
| Gain error                       | 0.05%, typ. max 0.1%        |
| Input ranges                     | +5, +-10, or 0.. 10V        |
| Overvoltage protection           | +15V max.                   |
| Common mode input voltage        | +10V max.                   |
| Channel scanning error (Gain=1): |                             |

| Scanning Rate (kHz) | Scanning error<br>(% of +-full scale) |
|---------------------|---------------------------------------|
| 10.. 500            | 0.0000 %                              |
| 600                 | 0.05% max.                            |
| 700                 | 0.075% max.                           |
| 800                 | 0.25% max.                            |
| 900                 | 0.4% max.                             |
| 1000                | 0.45% max.                            |
| 1250                | 1% max.                               |

### 12.3. A/D Converter

|  |                            |
|--|----------------------------|
| Type   | Successive approximation   |
| Resolution   | 12bit (2.44mV/4.88mV)      |
| Linearity error  | +1 LSB max. +-0.3 LSB typ. |
| Sampling Rate  | 1.25MHz max.               |
| -3dB bandwidth (for undersampling application)             | 4.2MHz                     |
| 11 effective bit bandwidth (for undersampling application) | 2.5MHz                     |

### 12.4. A/D Sample Buffer

|           |              |
|-----------|--------------|
| FIFO size | 1K/8K*16bits |
|-----------|--------------|

**12.5. Channel Gain table**

Size 1024\*24bits

**12.6. Clocks and Counters**

Based on ALTERA EPLD and CMOS 82C54

**12.7. Digital I/O**

|                    |   |
|--------------------|---|
| Input Output type  | TTL compatible                                |
| Numer of lines     | 8bit bit-programmable, 8bit byte programmable |
| Isource            | -8 mA   |
| Isink              | 8 mA  |
| Input termination  | 10 kOhm up to +5V                             |
| Output termination | 10 Ohm series resistor                        |

**12.8. D/A Converter and D/A circuitry**

|  |                            |
|--|----------------------------|
| Analog outputs                                   | 2 channels                 |
| Resolution                                       | 12bit                      |
| Output ranges                                    | +5V, +10V, 0.. 5V, 0.. 10V |
| Relative accuracy                                | +1LSB max.                 |
| Full-scale accuracy                              | +5LSB max                  |
| Non-linearity                                    | +1LSB max.                 |
| Settling time                                    | 5us typ.                   |
| Output current                                   | 5mA max.                   |
| Short circuit time at the external I/O connector | unlimited                  |

**12.9. D/A Sample Buffer**

FIFO size (each channel) 1K/8K\*16 bits

## Appendix A - The PCI Configuration Registers, Local Configuration Registers, Runtime Registers, DMA registers, Local Address Space 0 and 1

The first part of the Appendix shows the maps of all register areas.

PCI Configuration Registers:

| Configuration Address Offset | PCI Writable | Byte3  | Byte2       | Byte1                 | Byte0           |
|------------------------------|--------------|--|-------------|-----------------------|-----------------|
| 00h                          | No           | Device Identification  |             | Vendor Identification |                 |
| 04h                          | Yes          | Status   |             | Command               |                 |
| 08h                          | No           | Class Code   |             |                       | Revision        |
| 0Ch                          | Yes (7..0)   | BIST   | Header Type | PCI Latency Timer     | Cache Line Size |
| 10h                          | Yes          | PCI Base Address 0 for Memory Mapped Local Configuration Registers PCIBAR0 |             |                       |                 |
| 14h                          | Yes          | PCI Base Address 1 for I/O Mapped Local Configuration Registers PCIBAR1    |             |                       |                 |
| 18h                          | Yes          | PCI Base Address 2 for Local Address Space 0 (LAS0)                        |             |                       |                 |
| 1Ch                          | Yes          | PCI Base Address 3 for Local Address Space 1 (LAS1)                        |             |                       |                 |
| 20h                          | Yes          | Reserved   |             |                       |                 |
| 24h                          | Yes          | Reserved   |             |                       |                 |
| 28h                          | No           | Reserved   |             |                       |                 |
| 2Ch                          | No           | Subsystem ID   |             | Subsystem Vendor ID   |                 |
| 30h                          | Yes          | PCI Base Address for Local Expansion ROM                                   |             |                       |                 |
| 34h                          | No           | Reserved   |             |                       |                 |
| 38h                          | No           | Reserved   |             |                       |                 |
| 3Ch                          | Yes(7..0)    | Max_Lat  | Min_Gnt     | Interrupt Pin         | Interrupt Line  |

## Local Configuration Registers:

| PCI Address<br>Offset from<br>Local<br>Configuration<br>Registers Base<br>Address | PCI and<br>Serial<br>EEPROM<br>Writable | To ensure software compatibility with other versions of the PCI 9080 family<br>and to ensure compatibility with future enhancements, write 0 to all unused<br>bits.<br><br>31 <span style="float: right;">0</span> |
|---|---|--|
| 00h   | Yes                                     | LAS0RR - Range for PCI-to-Local Address Space 0  |
| 04h   | Yes                                     | LAS0BA - Local Base Address (Remap) for PCI-to-Local Address Space 0   |
| 08h   | Yes                                     | MARBR - Mode/Arbitration Register  |
| 0Ch   | Yes                                     | BIGEND - Big/Little Endian Description Register  |
| 10h   | Yes                                     | EROMRR - Range for Expansion ROM   |
| 14h   | Yes                                     | EROMBA - Local Base Address (Remap) for PCI to ROM   |
| 18h   | Yes                                     | LBRD0 - Local Address Space 0 Bus Region Description Register  |
| 1Ch   | Yes                                     | DMRR - Local Range Register for Direct Master to PCI   |
| 20h   | Yes                                     | DMLBAM - Local Base Address Register for Direct Master to PCI memory   |
| 24h   | Yes                                     | DMLBAI - Local Base Address Register for Direct Master to PCI IO/CFG   |
| 28h   | Yes                                     | DMPBAM - PCI Base Address Register for Direct Master to PCI memory   |
| 2Ch   | Yes                                     | DMCFGA - PCI Configuration Address Reg. for Direct Master to PCI<br>IO/CFG   |
| F0h   | Yes                                     | LAS1RR - Range for PCI-to-Local Address Space 1  |
| F4h   | Yes                                     | LAS1BA - Local Base Address (Remap) for PCI-to-Local Address Space 0   |
| F8h   | Yes                                     | LBRD1 - Local Address Space 1 Bus Region Description Register  |

## Runtime Registers:

| PCI<br>(Offset<br>from Base<br>Address) | PCI<br>Writable | Serial<br>EEPROM<br>Writable | To ensure software compatibility with other versions of the<br>PCI 9080 family and to ensure compatibility with future<br>enhancements, write 0 to all unused bits. |             |
|---|-----------------|------------------------------|---|-------------|
|   |                 |                              | 31  | 0           |
| 40h                                     | Yes             | Yes                          | Mailbox Register 0 (see Note)   |             |
| 44h                                     | Yes             | Yes                          | Mailbox Register 1 (see Note)   |             |
| 48h                                     | Yes             | No                           | Mailbox Register 2  |             |
| 4Ch                                     | Yes             | No                           | Mailbox Register 3  |             |
| 50h                                     | Yes             | No                           | Mailbox Register 4  |             |
| 54h                                     | Yes             | No                           | Mailbox Register 5  |             |
| 58h                                     | Yes             | No                           | Mailbox Register 6  |             |
| 5C                                      | Yes             | No                           | Mailbox Register 7  |             |
| 60h                                     | Yes             | No                           | PCI-to-Local Doorbell Register  |             |
| 64h                                     | Yes             | No                           | Local-to-PCI Doorbell Register  |             |
| 68h                                     | Yes             | No                           | Interrupt Control / Status  |             |
| 6Ch                                     | Yes             | No                           | Serial EEPROM Control, PCI Command Codes, User I/O<br>Control, Init Control   |             |
| 70h                                     | No              | No                           | Device ID   | Vendor ID   |
| 74h                                     | No              | No                           | Unused  | Revision ID |
| 78h                                     | Yes             | No                           | Mailbox Register 0 (see Note)   |             |
| 7Ch                                     | Yes             | No                           | Mailbox Register 1 (see Note)   |             |

**Note:** Mailbox registers 0 and 1 are always accessible at addresses 78h/C0h and 7Ch/C4. When the I2O feature is disabled (QSR[0]=0), Mailbox registers 0 and 1 are also accessible at PCI Addresses 40h and 44h for PCI 9060 compatibility. When the I2O feature is enabled, the Inbound and Outbound Queue pointers are accessed at addresses 40h and 44h, replacing the Mailbox registers in PCI Address space.

## DMA Registers:

| PCI<br>(Offset<br>from<br>PCIBAR0<br>Base<br>Address) | Local<br>Access<br>(Offset<br>from Chip<br>Select<br>Address) | To ensure software compatibility with other versions of the<br>PCI 9080 family and to ensure compatibility with future<br>enhancements, write 0 to all unused bits. |   | PCI/<br>Local<br>Writable                   | Serial<br>EEPROM<br>Writable |   |
|---|---|---|---|---|------------------------------|---|
|   |   | 31  | 0   |   |                              |   |
| 80h   | 100h  | DMA Ch 0 Mode   |   | Y   | N                            |   |
| 84h   | 104h  | DMA Ch 0 PCI Address  |   | Y   | N                            |   |
| 88h   | 108h  | DMA Ch 0 Local Address  |   | Y   | N                            |   |
| 8Ch   | 10Ch  | DMA Ch 0 Transfer Byte Count  |   | Y   | N                            |   |
| 90h   | 110h  | DMA Ch 0 Descriptor Pointer   |   | Y   | N                            |   |
| 94h   | 114h  | DMA Ch 1 Mode   |   | Y   | N                            |   |
| 98h   | 118h  | DMA Ch 1 PCI Address  |   | Y   | N                            |   |
| 9Ch   | 11Ch  | DMA Ch 1 Local Address  |   | Y   | N                            |   |
| A0h   | 120h  | DMA Ch 1 Transfer Byte Count  |   | Y   | N                            |   |
| A4h   | 124h  | DMA Ch 1 Descriptor Pointer   |   | Y   | N                            |   |
| A8h   | 128h  | Reserved  | DMA Channel1<br>Command/<br>Status Register | DMA Channel0<br>Command/<br>Status Register | Y                            | N |
| ACh   | 12Ch  | Mode/Arbitration Register   |   | Y   | N                            |   |
| B0h   | 130h  | DMA Threshold Register  |   | Y   | N                            |   |

LAS0 register area:

| Address<br>LAS0 base<br>offset (hexa) | Local Address Space 0 |
|---------------------------------------|-----------------------|
| 000<br>0FF                            | Runtime Area          |
| 100<br>1FF                            | Setup Area            |

The first part of Runtime Area of LAS0:

| Read Function                            | Write Function                                | Local Address<br>Space 0 Offset |
|--|---|---------------------------------|
|  | -   | 000h                            |
| -  | -   | 004h                            |
| Read User Inputs                         | Write User Outputs                            | 008h                            |
| -  | -   | 00Ch                            |
| Read FIFO Status                         | Software A/D Start                            | 010h                            |
| -  | Software D/A1 Update                          | 014h                            |
| -  | Software D/A2 Update                          | 018h                            |
| -  | -   | 01Ch                            |
| -  | -   | 020h                            |
| -  | Software Simultaneous<br>D/A1 and D/A2 Update | 024h                            |
| Software Pacer Start                     | Software Pacer Stop                           | 028h                            |
| Read Timer Counters<br>Status            | Software high-speed input<br>Sample Command   | 02Ch                            |
| Read Interrupt Status                    | Write Interrupt Enable<br>Mask Register       | 030h                            |
| Clear Interrupt set by<br>the Clear Mask | Set Interrupt Clear Mask                      | 034h                            |
| Read Interrupt Overrun<br>Register       | Clear Interrupt Overrun<br>Register           | 038h                            |
| -  | -   | 03Ch                            |

The Timer/Counter section and the Digital I/O section of the Runtime Area:

| <b>Read Function</b>  | <b>Write Function</b>   | <b>Local Address Space 0 Offset</b> |
|---|---|-------------------------------------|
| Read <i>Pacer Clock</i> Counter value (24 bit)                                | Load count in <i>Pacer Clock</i> Counter (24 bit)                     | 040h                                |
| Read <i>Burst Clock</i> Counter value (10 bit)                                | Load count in <i>Burst Clock</i> Counter (10 bit)                     | 044h                                |
| Read <i>A/D Sample counter</i> value (10 bit)                                 | Load count in <i>A/D Sample counter</i> (10 bit)                      | 048h                                |
| Read <i>D/A1 Update counter</i> value (10 bit)                                | Load count in <i>D/A1 Update counter</i> (10 bit)                     | 04Ch                                |
| Read <i>D/A2 Update counter</i> value (10 bit)                                | Load count in <i>D/A2 Update counter</i> (10 bit)                     | 050h                                |
| Read <i>Delay Counter</i> value (16 bit)                                      | Load count in <i>Delay Counter</i> (16 bit)                           | 054h                                |
| Read <i>About Counter</i> value (16 bit)                                      | Load count in <i>About Counter</i> (16 bit)                           | 058h                                |
| Read <i>DAC clock</i> value (16 bit)  | Load count in <i>DAC clock</i> (16 bit)                               | 05Ch                                |
| Read 8254 <i>User TC 0</i> value  | Load count in 8254 <i>User TC 0</i>                                   | 060h                                |
| Read 8254 <i>User TC 1</i> value  | Load count in 8254 <i>User TC 1</i>                                   | 064h                                |
| Read 8254 <i>User TC 2</i> value  | Load count in 8254 <i>User TC 2</i>                                   | 068h                                |
| Reserved  | Program counter mode for 8254 <i>User TC</i>                          | 06Ch                                |
| Read Port 0 digital input lines   | Program Port 0 digital output lines                                   | 070h                                |
| Read Port 1 digital input lines   | Program Port 1 digital output lines                                   | 074h                                |
| Clear digital IRQ status flag/read Port 0 direction, mask or compare register | Clear digital chip/program Port 0 direction, mask or compare register | 078h                                |
| Read Digital I/O Status word  | Program Digital Control Register & Digital Interrupt enable           | 07Ch                                |

The LAS1 Register Area:

| <b>Read Function</b>                  | <b>Write Function</b> | <b>Local Address<br/>Space 1 Offset<br/>hexa</b> |
|---------------------------------------|-----------------------|--|
| Read A/D FIFO                         | -                     | 0h<br>(16-bit)                                   |
| Read High Speed<br>Digital Input FIFO | -                     | 4h<br>(16-bit)                                   |
| -                                     | Write D/A1 FIFO       | 8h<br>(16-bit)                                   |
| -                                     | Write D/A2 FIFO       | Ch<br>(16-bit)                                   |

### A1. PCI Configuration Registers

The PCI configuration registers can be accessed by PCI BIOS calls. The meaning of the PCI configuration register is on the Table A1.2. If You use the board via RTD's software driver you do not have any doing with this area.

| Configuration Address Offset | PCI Writable | Byte3   | Byte2       | Byte1                 | Byte0           |
|------------------------------|--------------|---|-------------|-----------------------|-----------------|
| 00h                          | No           | Device Identification   |             | Vendor Identification |                 |
| 04h                          | Yes          | Status  |             | Command               |                 |
| 08h                          | No           | Class Code  |             |                       | Revision        |
| 0Ch                          | Yes (7..0)   | BIST  | Header Type | PCI Latency Timer     | Cache Line Size |
| 10h                          | Yes          | PCI Base Address 0 for Memory Mapped Local Configuration Registers<br>PCIBAR0 |             |                       |                 |
| 14h                          | Yes          | PCI Base Address 1 for I/O Mapped Local Configuration Registers<br>PCIBAR1    |             |                       |                 |
| 18h                          | Yes          | PCI Base Address 2 for Local Address Space 0 (LAS0)                           |             |                       |                 |
| 1Ch                          | Yes          | PCI Base Address 3 for Local Address Space 1 (LAS1)                           |             |                       |                 |
| 20h                          | Yes          | Reserved  |             |                       |                 |
| 24h                          | Yes          | Reserved  |             |                       |                 |
| 28h                          | No           | Reserved  |             |                       |                 |
| 2Ch                          | No           | Subsystem ID  |             | Subsystem Vendor ID   |                 |
| 30h                          | Yes          | PCI Base Address for Local Expansion ROM                                      |             |                       |                 |
| 34h                          | No           | Reserved  |             |                       |                 |
| 38h                          | No           | Reserved  |             |                       |                 |
| 3Ch                          | Yes(7..0)    | Max_Lat   | Min_Gnt     | Interrupt Pin         | Interrupt Line  |

Table A.1.1.

The content of the registers are described on the Table A.1.2

| Field  | Contents                 | Comment  |
|--|--------------------------|--|
| Vendor Identification  | 1435h                    | Value Assigned to Real Time Devices Inc. by the PCI Special Interest Group                                     |
| Device Identification  | 4520h                    | Type number of the Board   |
| Class Code   | FF0000h                  | No Applicable Class Code   |
| Cache Line Size  | 00h                      |  |
| PCI Latency Timer  | 00h                      |  |
| Header Type  | 00h                      | Single Function PCI Device   |
| BIST   | 00h                      | The Built In Self Test is not Supported  |
| PCI Base Address 0 for Memory Mapped Local Configuration Registers | Assigned by the PCI BIOS | Controls the operation of local system   |
| PCI Base Address 1 for I/O Mapped Local Configuration Registers    | Assigned by the PCI BIOS | Controls the operation of local system   |
| PCI Base Address 2 for Local Address Space 0 (LAS0)                | Assigned by the PCI BIOS | LAS0 is the base address of the configuration/setup area and Timer/Counter, Digital I/O chip of PCI4520/DM7520 |
| PCI Base Address 3 for Local Address Space 1 (LAS1)                | Assigned by the PCI BIOS | LAS1 is the base address of the A/D, D/A, and High-Speed Digital Input data transfer area of PCI4520/DM7520    |
| Subsystem ID   | 9080h                    |  |
| Subsystem Vendor ID  | 10B5h                    |  |
| PCI Base Address for Local Expansion ROM                           | 00000000h                | No external BIOS   |
| Interrupt Line   | 0xh                      | Interrupt Line Assigned by the BIOS  |
| Interrupt Pin  | 01h                      | INTA# Interrupt  |
| Min_Gnt  | 00h                      |  |
| Max_Lat  | 00h                      |  |

Table A.1.2.

**A.1.1. PCIHDR - Device ID, Vendor ID (PCI CFG offset:00, EEPROM offset:00)**

|      |    |      |    |      |    |      |    |      |    |      |   |      |   |      |   |
|------|----|------|----|------|----|------|----|------|----|------|---|------|---|------|---|
| 31   | 28 | 27   | 24 | 23   | 20 | 19   | 16 | 15   | 12 | 11   | 8 | 7    | 4 | 3    | 0 |
| 0100 |    | 0101 |    | 0010 |    | 0000 |    | 0001 |    | 0100 |   | 0011 |   | 0101 |   |
| 4    |    | 5    |    | 2    |    | 0    |    | 1    |    | 4    |   | 3    |   | 5    |   |

**45201435**

**A.1.2. PCICCR - Class Code (PCI CFG offset:09- 0B, EEPROM offset:04)**

|      |    |      |    |      |    |      |    |      |    |      |   |      |   |      |   |
|------|----|------|----|------|----|------|----|------|----|------|---|------|---|------|---|
| 31   | 28 | 27   | 24 | 23   | 20 | 19   | 16 | 15   | 12 | 11   | 8 | 7    | 4 | 3    | 0 |
| 1111 |    | 1111 |    | 0000 |    | 0000 |    | 0000 |    | 0000 |   | 0000 |   | 0000 |   |
| F    |    | F    |    | 0    |    | 0    |    | 0    |    | 0    |   | 0    |   | 0    |   |

**FF000000**

**A.1.3. PCICLSR, PCI LTR, PCI HTR, PCIIPR PCIILR - (PCI CFG offset:0C.. 0E, 3D, 3C, EEPROM offset:08)**

|      |    |      |    |      |    |      |    |      |    |      |   |      |   |      |   |
|------|----|------|----|------|----|------|----|------|----|------|---|------|---|------|---|
| 31   | 28 | 27   | 24 | 23   | 20 | 19   | 16 | 15   | 12 | 11   | 8 | 7    | 4 | 3    | 0 |
| 0000 |    | 0000 |    | 0000 |    | 0000 |    | 0000 |    | 0001 |   | 0000 |   | 0000 |   |
| 0    |    | 0    |    | 0    |    | 0    |    | 0    |    | 1    |   | 0    |   | 0    |   |

**00000100**

**A.1.4. PCISVID - PCI Subsystem Vendor ID (PCI CFG offset:2C, EEPROM offset:44)**

|      |    |      |    |      |    |      |    |      |    |      |   |      |   |      |   |
|------|----|------|----|------|----|------|----|------|----|------|---|------|---|------|---|
| 31   | 28 | 27   | 24 | 23   | 20 | 19   | 16 | 15   | 12 | 11   | 8 | 7    | 4 | 3    | 0 |
| 1001 |    | 0000 |    | 1000 |    | 0000 |    | 0001 |    | 0000 |   | 1011 |   | 0101 |   |
| 9    |    | 0    |    | 8    |    | 0    |    | 1    |    | 0    |   | B    |   | 5    |   |

**908010B5**

**A.1.5. PEROMBA - Expansion ROM PCI Base Address Register(PCI CFG offset:30, EEPROM offset:54)**

|      |    |      |    |      |    |      |    |      |    |      |   |      |   |      |   |
|------|----|------|----|------|----|------|----|------|----|------|---|------|---|------|---|
| 31   | 28 | 27   | 24 | 23   | 20 | 19   | 16 | 15   | 12 | 11   | 8 | 7    | 4 | 3    | 0 |
| 0000 |    | 0000 |    | 0000 |    | 0000 |    | 0000 |    | 0000 |   | 0000 |   | 0000 |   |
| 0    |    | 0    |    | 0    |    | 0    |    | 0    |    | 0    |   | 0    |   | 0    |   |

**00000000**

**A.2. Local Configuration Registers**

| PCI Address<br>Offset from<br>Local<br>Configuration<br>Registers Base<br>Address | PCI and<br>Serial<br>EEPROM<br>Writable | 32 bit registers  |
|---|---|---|
| 00h   | Yes                                     | LAS0RR - Range for PCI-to-Local Address Space 0                         |
| 04h   | Yes                                     | LAS0BA - Local Base Address (Remap) for PCI-to-Local Address Space 0    |
| 08h   | Yes                                     | MARBR - Mode/Arbitration Register                                       |
| 0Ch   | Yes                                     | BIGEND - Big/Little Endian Description Register                         |
| 10h   | Yes                                     | EROMRR - Range for Expansion ROM  |
| 14h   | Yes                                     | EROMBA - Local Base Address (Remap) for PCI to ROM                      |
| 18h   | Yes                                     | LBRD0 - Local Address Space 0 Bus Region Description Register           |
| 1Ch   | Yes                                     | DMRR - Local Range Register for Direct Master to PCI                    |
| 20h   | Yes                                     | DMLBAM - Local Base Address Register for Direct Master to PCI memory    |
| 24h   | Yes                                     | DMLBAI - Local Base Address Register for Direct Master to PCI IO/CFG    |
| 28h   | Yes                                     | DMPBAM - PCI Base Address Register for Direct Master to PCI memory      |
| 2Ch   | Yes                                     | DMCFGA - PCI Configuration Address Reg. for Direct Master to PCI IO/CFG |
| F0h   | Yes                                     | LAS1RR - Range for PCI-to-Local Address Space 1                         |
| F4h   | Yes                                     | LAS1BA - Local Base Address (Remap) for PCI-to-Local Address Space 0    |
| F8h   | Yes                                     | LBRD1 - Local Address Space 1 Bus Region Description Register           |

Table 4.2.1.

### A.2.1. Range for PCI-to-Local Address Space 0 Register (LAS0RR, PCI:00h, EEPROM offset: 14)

The Local Address Space 0 (LAS0) is a 32 bit wide, 512 byte long Memory-mapped area with zero Wait states without burst access.

|      |    |    |    |      |    |    |    |      |    |    |   |      |   |   |   |      |  |  |  |      |  |  |  |   |  |  |  |
|------|----|----|----|------|----|----|----|------|----|----|---|------|---|---|---|------|--|--|--|------|--|--|--|---|--|--|--|
| 31   | 28 | 27 | 24 | 23   | 20 | 19 | 16 | 15   | 12 | 11 | 8 | 7    | 4 | 3 | 0 |      |  |  |  |      |  |  |  |   |  |  |  |
| 1111 |    |    |    | 1111 |    |    |    | 1111 |    |    |   | 1110 |   |   |   | 0000 |  |  |  | 0000 |  |  |  |   |  |  |  |
| F    |    |    |    | F    |    |    |    | F    |    |    |   | F    |   |   |   | E    |  |  |  | 0    |  |  |  | 0 |  |  |  |

**FFFFFFE0**

bit 0: 1 Memory Space Indicator

bit 2..1: 00 Locate anywhere in 32 bit PCI address space

bit 3: 0 - No prefetch

bit 31.. 4: Specifies PCI address bits used to decode PCI access to local bus Space Each of the bits correspond to an address bit. Bit 31 corresponds to address bit 31. A value of 1 indicates the bits should be included in decode. Write a value of 0 to all others.

### A.2.2 Local Base Address (Remap) for PCI-to-Local Address Space 0 Register (LAS0BA, PCI: 04, EEPROM offset: 18)

The Local Address Space 0 (LAS0) is a 16 bit wide, 32 byte long I/O area without Wait states, without burst access.

|      |    |    |    |      |    |    |    |      |    |    |   |      |   |   |   |      |  |  |  |
|------|----|----|----|------|----|----|----|------|----|----|---|------|---|---|---|------|--|--|--|
| 31   | 28 | 27 | 24 | 23   | 20 | 19 | 16 | 15   | 12 | 11 | 8 | 7    | 4 | 3 | 0 |      |  |  |  |
| 0000 |    |    |    | 0000 |    |    |    | 0000 |    |    |   | 0000 |   |   |   | 0001 |  |  |  |
| 0    |    |    |    | 0    |    |    |    | 0    |    |    |   | 0    |   |   |   | 1    |  |  |  |

**00000001**

bit 0: 1 Space 0 enable. A value of 1 enables decode of PCI Address for direct slave access to local space0

bit 1: Unused 0

bit 3.. 2: Not used

bit 31.. 4: The bits in this register replace the PCI address bits used in decode as the local address bits.

### A.2.3 Mode/Arbitration Register (MARBR, PCI: 08, EEPROM offset: 1C)

|      |    |    |    |      |    |    |    |      |    |    |   |      |   |   |   |      |  |  |  |
|------|----|----|----|------|----|----|----|------|----|----|---|------|---|---|---|------|--|--|--|
| 31   | 28 | 27 | 24 | 23   | 20 | 19 | 16 | 15   | 12 | 11 | 8 | 7    | 4 | 3 | 0 |      |  |  |  |
| 0000 |    |    |    | 0000 |    |    |    | 0010 |    |    |   | 0000 |   |   |   | 0000 |  |  |  |
| 0    |    |    |    | 0    |    |    |    | 2    |    |    |   | 0    |   |   |   | 0    |  |  |  |

**00200000**

bit 7:0: Local Bus Latency Timer. Number of Local Bus Clock cycles before de-asserting HOLD and releasing the Local Bus. Also used with bit 27 to delay BREQ input to give up the Local Bus only when this timer expires.

bit 15:8: Local Bus Pause Timer. Number of Local Bus Clock cycles before reasserting HOLD after releasing the Local Bus.

**Note:** Applicable only to DMA operation.

bit 16 Local Bus Latency Timer Enable. Value of 1 enables latency timer.

bit 17 Local Bus Pause Timer Enable. Value of 1 enables pause timer.

- bit 18 Local Bus BREQ Enable. Value of 1 enables Local Bus BREQ input. When BREQ input is active, the PCI 9080 de-asserts HOLD and releases Local Bus.
- bit 20:19 DMA Channel Priority. Value of 00 indicates rotational priority scheme. Value of 01 indicates Channel 0 has priority. Value of 10 indicates Channel 1 has priority. Value of 11 is reserved.
- bit 21 Local Bus Direct Slave Give up Bus Mode. When set to 1, the PCI 9080 de-asserts HOLD and releases the Local Bus when the Direct Slave Write FIFO becomes empty during a Direct Slave Write or when the Direct Slave Read FIFO becomes full during a Direct Slave Read.
- bit 22 Direct Slave LLOCKo# Enable. Value of 1 enables PCI Direct Slave locked sequences. Value of 0 disables Direct Slave locked sequences.
- bit 23 PCI Request Mode. Value of 1 causes the PCI 9080 to de-assert REQ when it asserts FRAME during a Master cycle. Value of 0 causes the PCI 9080 to leave REQ asserted for the entire Bus Master cycle.
- bit 24 PCI Specification v2.1 Mode. When set to 1, the PCI 9080 operates in Delayed Transaction mode for Direct Slave Reads. The PCI 9080 issues a Retry and prefetches Read data.
- bit 25 PCI Read No Write Mode. Value of 1 forces Retry on Writes if Read is pending. Value of 0 bit allows Writes to occur while Read is pending.
- bit 26 PCI Read with Write Flush Mode. Value of 1 submits request to flush pending a Read cycle if a Write cycle is detected. Value of 0 submits request to not effect pending Reads when a Write cycle occurs (PCI Specification v2.1 compatible).
- bit 27 Gate Local Bus Latency Timer with BREQ. If set to 0, the PCI 9080 gives up the Local Bus during Direct Slave or DMA transfer after the current cycle (if enabled and BREQ is sampled). If set to 1, the PCI 9080 gives up the Local Bus only if BREQ is sampled and the Local Bus Latency Timer is enabled and expired during a Direct Slave or DMA transfer.
- bit 28 PCI Read No Flush Mode. Value of 1 submits a request to not flush the Read FIFO if a PCI Read cycle completes (Read Ahead mode). Value of 0 submits a request to flush the Read FIFO if a PCI Read cycle completes.
- bit 29 If set to 0, reads from PCI Configuration register address 00h and returns Device ID and Vendor ID. If set to 1, reads from PCI Configuration Register address 00h and returns Subsystem ID and Subsystem Vendor ID.
- bit 31:30 Reserved.

**A.2.4 Big/Little Endian Descriptor Register (BIGEND, PCI:0Ch, EEPROM offset: 20h)**

|      |    |      |    |      |    |      |    |      |    |      |   |      |   |      |   |
|------|----|------|----|------|----|------|----|------|----|------|---|------|---|------|---|
| 31   | 28 | 27   | 24 | 23   | 20 | 19   | 16 | 15   | 12 | 11   | 8 | 7    | 4 | 3    | 0 |
| 0000 |    | 0000 |    | 0000 |    | 0000 |    | 0000 |    | 0000 |   | 0000 |   | 0000 |   |
| 0    |    | 0    |    | 0    |    | 0    |    | 0    |    | 0    |   | 0    |   | 0    |   |

**00000000**

- bit 0: Configuration Register Big Endian Mode. Value of 1 specifies use of Big Endian data ordering for Local accesses to the Configuration registers. Value of 0 specifies Little Endian ordering. Big Endian mode can be specified for Configuration Register accesses by asserting BIGEND# pin during Address phase of access.
- bit 1: Direct Master Big Endian Mode. Value of 1 specifies use of Big Endian data ordering for Direct Master accesses. Value of 0 specifies Little Endian ordering. Big Endian mode can be specified for Direct Master accesses by asserting the BIGEND# input pin during Address phase of access.
- bit 2: Direct Slave Address Space 0 Big Endian Mode. Value of 1 specifies use of Big Endian data ordering for Direct Slave accesses to Local Address Space 0. Value of 0 specifies Little Endian ordering.
- bit 3: Direct Slave Address Expansion ROM 0 Big Endian Mode. Value of 1 specifies use of Big Endian data ordering for Direct Slave accesses to Expansion ROM. Value of 0 specifies Little Endian ordering.
- bit 4: Big Endian Byte Lane Mode. Value of 1 specifies that in Big Endian mode, use byte lanes [31:16] for 16-bit Local Bus and byte lanes [31:24] for 8-bit Local Bus. Value of 0 specifies that in Big Endian mode, byte lanes [15:0] be used for 16-bit Local Bus and byte lanes [7:0] for 8-bit Local Bus.

bit 5: Direct Slave Address Space 1 Big Endian Mode. Value of 1 specifies use of Big Endian data ordering for Direct Slave accesses to Local Address Space 1. Value of 0 specifies Little Endian ordering.

bit 6: DMA Channel 1 Big Endian Mode. Value of 1 specifies use of Big Endian data ordering for DMA Channel 1 accesses to the Local Address Space. Value of 0 specifies Little Endian ordering.

bit 7: DMA Channel 0 Big Endian Mode. Value of 1 specifies use of Big Endian data ordering for DMA Channel 0 accesses to the Local Address Space. Value of 0 specifies Little Endian ordering.

bit 31:8: Reserved.

### A.2.5 Expansion ROM Range Register (EROMRR, PCI:10h, EEPROM offset: 24h)

|      |    |      |    |      |    |      |    |      |    |      |   |      |   |      |   |
|------|----|------|----|------|----|------|----|------|----|------|---|------|---|------|---|
| 31   | 28 | 27   | 24 | 23   | 20 | 19   | 16 | 15   | 12 | 11   | 8 | 7    | 4 | 3    | 0 |
| 0000 |    | 0000 |    | 0000 |    | 0000 |    | 0000 |    | 0000 |   | 0000 |   | 0000 |   |
| 0    |    | 0    |    | 0    |    | 0    |    | 0    |    | 0    |   | 0    |   | 0    |   |

**00000000**

bit 10:0: Reserved.

bit 31:11: Specifies which PCI Address bits to use for decoding PCI-to-Local Bus Expansion ROM. Each bit corresponds to a PCI Address bit. Bit 31 corresponds to Address bit 31. Write 1 to all bits to be included in decode and 0 to all others (used in conjunction with PCI Configuration register 30h). Default is 64 KB.

**Note:** Range (**not** Range register) must be power of 2. “Range register value” is inverse of range.

### A.2.6 Expansion ROM Local Base Address (Remap) Register and BREQo Control (EROMBA, PCI:14h, EEPROM offset: 28h)

|      |    |      |    |      |    |      |    |      |    |      |   |      |   |      |   |
|------|----|------|----|------|----|------|----|------|----|------|---|------|---|------|---|
| 31   | 28 | 27   | 24 | 23   | 20 | 19   | 16 | 15   | 12 | 11   | 8 | 7    | 4 | 3    | 0 |
| 0000 |    | 0000 |    | 0000 |    | 0000 |    | 0000 |    | 0000 |   | 0000 |   | 0000 |   |
| 0    |    | 0    |    | 0    |    | 0    |    | 0    |    | 0    |   | 0    |   | 0    |   |

**00000000**

bit 3:0: Direct Slave BREQo (Backoff Request Out) Delay Clocks. Number of Local Bus clocks in which Direct Slave HOLD request is pending and a Local Direct Master access is in progress and not being granted the bus (LHOLDA) before asserting BREQo. Once asserted, BREQo remains asserted until the PCI 9080 receives LHOLDA (LSB = 8 or 64 clocks).

bit 4: Local Bus BREQo Enable. Value of 1 enables the PCI 9080 to assert BREQo output.

5 BREQo Timer-Resolution. Value of 1 changes LSB of the BREQo timer from 8 to 64 clocks.

bit 10:6: Reserved. Yes No 0

bit 31:11: Remap of PCI Expansion ROM Space into a Local Address Space. Remap (replace) PCI Address bits used in decode as Local Address bits.

**Note:** Remap Address value must be multiple of Range (**not** Range register).

### A.2.7 Local Address Space 0/Expansion ROM Bus Region Descriptor Register (LBRD0; PCI:18h, EEPROM offset: 2Ch)

|      |    |      |    |      |    |      |    |      |    |      |   |      |   |      |   |
|------|----|------|----|------|----|------|----|------|----|------|---|------|---|------|---|
| 31   | 28 | 27   | 24 | 23   | 20 | 19   | 16 | 15   | 12 | 11   | 8 | 7    | 4 | 3    | 0 |
| 0100 |    | 0010 |    | 0000 |    | 0000 |    | 0000 |    | 0001 |   | 0100 |   | 0011 |   |
| 4    |    | 2    |    | 0    |    | 0    |    | 0    |    | 1    |   | 4    |   | 3    |   |

#### 42000143

bit 1:0: Memory Space 0 Local Bus Width. Value of 00 indicates bus width of 8 bits. Value of 01 indicates bus width of 16 bits. Value of 10 or 11 indicates bus width of 32 bits. S = 01, J = 11, C = 11

bit 5:2: Memory Space 0 Internal Wait States (data to data; 0-15 wait states).

6 Memory Space 0 Ready Input Enable. Value of 1 enables Ready input. Value of 0 disables Ready input.

bit 7: Memory Space 0 BTERM# Input Enable. Value of 1 enables BTERM# input. Value of 0 disables BTERM# input. If set to 0, the PCI 9080 bursts four Lword maximum at a time.

bit 8: Memory Space 0 Prefetch Disable. If mapped into memory space, value of 0 enables Read prefetching. Value of 1 disables prefetching. If prefetching is disabled, the PCI 9080 disconnects after each memory read.

bit 9: Expansion ROM Space Prefetch Disable. Value of 0 enables Read prefetching. Value of 1 disables prefetching. If prefetching is disabled, the PCI 9080 disconnects after each memory read.

bit 10: Read Prefetch Count Enable. When set to 1 and memory prefetching is enabled, the PCI 9080 prefetches up to the number of Lwords specified in prefetch count. When set to 0, the PCI 9080 ignores the count and continues prefetching until terminated by PCI Bus.

bit 14:11: Prefetch Counter. Number of Lwords to prefetch during Memory Read cycles (0-15). Count of zero selects prefetch of 16 Lwords.

bit 15: Reserved.

bit 17:16: Expansion ROM Space Local Bus Width. Value of 00 indicates bus width of 8 bits. Value of 01 indicates bus width of 16 bits. Value of 10 or 11 indicates bus width of 32 bits. S = 01, J = 11, C = 11

bit 21:18: Expansion ROM Space Internal Wait States (data to data; 0-15 wait states).

bit 22: Expansion ROM Space Ready Input Enable. Value of 1 enables Ready input. Value of 0 disables Ready input.

bit 23: Expansion ROM Space Bterm Input Enable. Value of 1 enables BTERM# input. Value of 0 disables Bterm input. If set to 0, the PCI 9080 bursts four Lword maximum at a time.

bit 24: Memory Space 0 Burst Enable. Value of 1 enables bursting. Value of 0 disables bursting. If burst is disabled, Local Bus performs continuous single cycles for Burst PCI Read/Write cycles.

bit 25: Extra Long Load from Serial EEPROM. Value of 1 loads Subsystem ID and Local Address Space 1 registers. Value of 0 indicates not to load them.

bit 26: Expansion ROM Space Burst Enable. Value of 1 enables bursting. Value of 0 disables bursting. If burst is disabled, Local Bus performs continuous single cycles for Burst PCI Read/Write cycles.

bit 27: Direct Slave PCI Write Mode. Value of 0 indicates the PCI 9080 should disconnect when the Direct Slave Write FIFO is full. Value of 1 indicates the PCI 9080 should de-assert TRDY# when the Write FIFO is full.

bit 31:28: PCI Target Retry Delay Clocks. Contains value (multiplied by 8) of the number of PCI Bus clocks after receiving PCI -to-Local Read or Write access and not successfully completing a transfer. Only pertains to Direct Slave Writes when bit 27 is set to 1.

### A.2.8 Local Range Register for Direct Master to PCI (DMRR; PCI:1Ch, EEPROM offset: 30h)

|      |    |      |    |      |    |      |    |      |    |      |   |      |   |      |   |
|------|----|------|----|------|----|------|----|------|----|------|---|------|---|------|---|
| 31   | 28 | 27   | 24 | 23   | 20 | 19   | 16 | 15   | 12 | 11   | 8 | 7    | 4 | 3    | 0 |
| 0000 |    | 0000 |    | 0000 |    | 0000 |    | 0000 |    | 0000 |   | 0000 |   | 0000 |   |
| 0    |    | 0    |    | 0    |    | 0    |    | 0    |    | 0    |   | 0    |   | 0    |   |

**00000000**

bit 15:0: Reserved (64 KB increments).

bit 31:16: Specifies which Local Address bits to use for decoding Local-to-PCI Bus access. Each bit corresponds to a PCI Address bit. Bit 31 corresponds to Address bit 31. Write 1 to all bits that must be included in decode and 0 to all others. Used for Direct Master Memory, I/O, or Configuration accesses.

**Note:** Range (**not** Range register) must be power of 2. “Range register value” is inverse of range.

### A.2.9 Local Bus Base Address Register for Direct Master to PCI Memory (DMLBAM; PCI:20h, EEPROM offset: 34h)

|      |    |      |    |      |    |      |    |      |    |      |   |      |   |      |   |
|------|----|------|----|------|----|------|----|------|----|------|---|------|---|------|---|
| 31   | 28 | 27   | 24 | 23   | 20 | 19   | 16 | 15   | 12 | 11   | 8 | 7    | 4 | 3    | 0 |
| 0000 |    | 0000 |    | 0000 |    | 0000 |    | 0000 |    | 0000 |   | 0000 |   | 0000 |   |
| 0    |    | 0    |    | 0    |    | 0    |    | 0    |    | 0    |   | 0    |   | 0    |   |

**00000000**

bit 15:0: Reserved. Yes No 0

bit 31:16: Assigns value to bits to use for decoding Local-to-PCI Memory access.

**Note:** Local Base Address value must be multiple of Range (**not** Range register).

### A.2.10 Local Base Address Register for Direct Master to PCI IO/CFG (DMLBAI; PCI:24h, EEPROM offset: 38h)

|      |    |      |    |      |    |      |    |      |    |      |   |      |   |      |   |
|------|----|------|----|------|----|------|----|------|----|------|---|------|---|------|---|
| 31   | 28 | 27   | 24 | 23   | 20 | 19   | 16 | 15   | 12 | 11   | 8 | 7    | 4 | 3    | 0 |
| 0000 |    | 0000 |    | 0000 |    | 0000 |    | 0000 |    | 0000 |   | 0000 |   | 0000 |   |
| 0    |    | 0    |    | 0    |    | 0    |    | 0    |    | 0    |   | 0    |   | 0    |   |

**00000000**

bit 15:0: Reserved.

bit 31:16: Assigns value to bits to use for decoding Local-to-PCI I/O or Configuration access. Used for Direct Master I/O and Configuration accesses.

**Notes:** Local Base Address value must be multiple of Range (**not** Range register). Refer to DMPBAM[13] for I/O Remap Address option.

### A.2.11 PCI Base Address (Remap) Register for Direct Master to PCI Memory(DMPBAM; PCI:28h, EEPROM offset: 3Ch)

|      |    |      |    |      |    |      |    |      |    |      |   |      |   |      |   |
|------|----|------|----|------|----|------|----|------|----|------|---|------|---|------|---|
| 31   | 28 | 27   | 24 | 23   | 20 | 19   | 16 | 15   | 12 | 11   | 8 | 7    | 4 | 3    | 0 |
| 0000 |    | 0000 |    | 0000 |    | 0000 |    | 0000 |    | 0000 |   | 0000 |   | 0000 |   |
| 0    |    | 0    |    | 0    |    | 0    |    | 0    |    | 0    |   | 0    |   | 0    |   |

**00000000**

bit 0: Direct Master Memory Access Enable. Value of 1 enables decode of Direct Master Memory accesses. Value of 0 disables decode of Direct Master Memory accesses.

bit 1: Direct Master I/O Access Enable. Value of 1 enables decode of Direct Master I/O accesses. Value of 0 disables decode of Direct Master I/O accesses.

bit 2: LLOCK# Input Enable. Value of 1 enables LLOCK# input, enabling PCI-lockedsequences. Value of 0 disables LLOCK# input.

bit 12, 3: Direct Master Read Prefetch Size control. Values:

00 = The PCI 9080 continues to prefetch Read data from the PCI Bus until the Direct Master access is finished. May result in additional four unneeded Lwordsbeing prefetched from the PCI Bus.

01 = Prefetch up to four Lwords from the PCI Bus

10 = Prefetch up to eight Lwords from the PCI Bus

11 = Prefetch up to 16 Lwords from the PCI Bus

If PCI memory prefetch is not wanted, performs Direct Master Single cycle. Direct Master Burst reads must not exceed programmed limit.

bit 4: Direct Master PCI Read Mode. Value of 0 indicates the PCI 9080 should release PCI Bus when the Read FIFO becomes full. Value of 1 indicates the PCI 9080 should keep PCI Bus and de-assert IRDY when the Read FIFO becomes full.

bit 10, 8:5: Programmable Almost Full Flag. When the number of entries in the 32-word Direct Master Write FIFO exceeds this value, output pin DMPAF# is asserted low.

bit 9: Write and Invalidate Mode. When set to 1, the PCI 9080 waits for 8 or 16 Lwords to be written from the Local Bus before starting PCI access. When set, all Local Direct Master to PCI Write accesses must be 8- or 16-Lword bursts. Use in conjunction with PCICR[4] and Section 3.6.1.9.2, "Direct Master Write and Invalidate".

bit 11: Direct Master Prefetch Limit. If set to 1, don't prefetch past 4 KB (4098 bytes) boundaries.

bit 13: I/O Remap Select. When set to 1, forces PCI Address bits [31:16] to all zeros. When set to 0, uses bits [31:16] of this register as PCI Address bits [31:16].

bit 15:14: Direct Master Write Delay. Used to delay PCI Bus request after Direct Master Burst Write cycle has started. Values:

00 = No delay; start cycle immediately

01 = Delay 4 PCI clocks

10 = Delay 8 PCI clocks

11 = Delay 16 PCI clocks

bit 31:16: Remap of Local-to-PCI Space into PCI Address Space. Remap (replace) Local Address bits used in decode as PCI Address bits. Used for Direct Master Memoryand I/O accesses.

**Note:** Remap Address value must be multiple of Range (**not** Range register).

**A.2.12 PCI Configuration Address Register for Direct Master to PCI IO/CFG (DMCFGA; PCI:2Ch, EEPROM offset: 40h)**

|      |    |      |    |      |    |      |    |      |    |      |   |      |   |      |   |
|------|----|------|----|------|----|------|----|------|----|------|---|------|---|------|---|
| 31   | 28 | 27   | 24 | 23   | 20 | 19   | 16 | 15   | 12 | 11   | 8 | 7    | 4 | 3    | 0 |
| 0000 |    | 0000 |    | 0000 |    | 0000 |    | 0000 |    | 0000 |   | 0000 |   | 0000 |   |
| 0    |    | 0    |    | 0    |    | 0    |    | 0    |    | 0    |   | 0    |   | 0    |   |

**00000000**

bit 1:0: Configuration Type (00=Type 0, 01=Type 1). 0  
 bit 7:2: Register Number. If different register Read/Write is needed, value must be programmed and new PCI Configuration cycle must be generated.  
 bit 10:8: Function Number.  
 bit 15:11: Device Number.  
 bit 23:16: Bus Number.  
 bit 30:24: Reserved.  
 bit 31: Configuration Enable. Value of 1 allows Local-to-PCI I/O accesses to be converted to a PCI Configuration cycle. Parameters in this table are used to generate PCI configuration address.  
**Note:** Refer to Configuration Cycle Generation example in Section 3.6.1.6, “CFG (PCI Configuration Type 0 or Type 1Cycles).”

**A.2.13 PCI Local Address Space 1 Range Register for PCI-to-Local Bus (LAS1RR; PCI:F0h, EEPROM offset: 48h)**

The Local Address Space 1 (LAS1) is a 16 bit wide, 16 byte long Memory-mapped area with zero Wait states with burst access.

|      |    |      |    |      |    |      |    |      |    |      |   |      |   |      |   |
|------|----|------|----|------|----|------|----|------|----|------|---|------|---|------|---|
| 31   | 28 | 27   | 24 | 23   | 20 | 19   | 16 | 15   | 12 | 11   | 8 | 7    | 4 | 3    | 0 |
| 1111 |    | 1111 |    | 1111 |    | 1111 |    | 1111 |    | 1111 |   | 1111 |   | 0000 |   |
| F    |    | F    |    | F    |    | F    |    | F    |    | F    |   | F    |   | 0    |   |

**FFFFFFF0**

bit 0: Memory Space Indicator. Value of 0 indicates Local Address Space 1 maps into PCI memory space. Value of 1 indicates Address Space 1 maps into PCI I/O space.  
 bit 2:1: If mapped into memory space, encoding is as follows:  
 00 Locate anywhere in 32-bit PCI Address space  
 01 Locate below 1 MB in PCI Address space  
 10 Locate anywhere in 64-bit PCI Address space  
 11 Reserved  
 If mapped into I/O space, bit 1 must be set to 0. Bit 2 is included with bits [31:3] to indicate decoding range.  
 bit 3: If mapped into memory space, value of 1 indicates reads are prefetchable (does not affect operation of the PCI 9080, but is used for system status). If mapped into I/O space, bit is included with bits [31:2] to indicate decoding range.  
 bit 31:4: Specifies which PCI Address bits to use for decoding PCI access to Local Bus Space 1. Each bit corresponds to a PCI Address bit. Bit 31 corresponds to Address bit 31. Write 1 to all bits that must be included in decode and 0 to all others (used in conjunction with PCI Configuration Register Ch 1). Default is 1 MB.  
**Notes:** Range (**not** Range register) must be power of 2. “Range register value” is inverse of range. User should limit all I/O spaces to 256 bytes per PCI Specification v2.1. If QSR bit 0 is set, defines PCI Base Address 0.

### A.2.14 Local Address Space 1 Local Base Address (Remap) Register(LAS1BA; PCI:F4h, EEPROM offset: 4Ch)

| 31 | 28 | 27 | 24 | 23 | 20 | 19 | 16 | 15 | 12 | 11 | 8 | 7 | 4 | 3 | 0 |
|----|----|----|----|----|----|----|----|----|----|----|---|---|---|---|---|
| 0  | 1  | 0  | 0  | 0  | 0  | 0  | 0  | 0  | 0  | 0  | 0 | 0 | 0 | 0 | 0 |
| 4  |    | 0  |    | 0  |    | 0  |    | 0  |    | 0  |   | 0 |   | 0 | 1 |

**40000001**

bit 0: Space 1 Enable. Value of 1 enables decoding of PCI Addresses for Direct Slave access to Local Space 1. Value of 0 disables decoding. If set to 0, PCI BIOS may not allocate (assign) base address for Space 1.

**Note:** Must be set to 1 for any Direct Slave access to Space 1.

bit 1: Reserved.

bit 3:2: If Local Space 1 is mapped into memory space, bits are not used. If mapped into I/O space, bit is included with bits [31:4] for remapping.

bit 31:4: Remap of PCI Address to Local Address Space 1 into a Local Address Space. Remap (replace) PCI Address bits used in decode as Local Address bits.

**Note:** Remap Address value must be multiple of Range (**not** Range register).

### A.2.15 Local Address Space 1 Bus Region Descriptor Register (LBRD1; PCI:F8h, EEPROM offset: 50h)

| 31 | 28 | 27 | 24 | 23 | 20 | 19 | 16 | 15 | 12 | 11 | 8 | 7 | 4 | 3 | 0 |
|----|----|----|----|----|----|----|----|----|----|----|---|---|---|---|---|
| 0  | 0  | 0  | 0  | 0  | 0  | 0  | 0  | 0  | 0  | 0  | 0 | 1 | 1 | 0 | 0 |
| 0  |    | 0  |    | 0  |    | 0  |    | 0  |    | 1  |   | C |   | 1 | 1 |

**000001C1**

bit 1:0 Memory Space 1 Local Bus Width. Value of 00 indicates bus width of 8 bits. Value of 01 indicates bus width of 16 bits. Value of 10 or 11 indicates bus width of 32 bits.

J = 11

C = 11

bit 5:2: Memory Space 1 Internal Wait States (data to data; 0-15 wait states).

bit 6: Memory Space 1 Ready Input Enable. Value of 1 enables Ready input. Value of 0 disables Ready input.

bit 7: Memory Space 1 BTERM# Input Enable. Value of 1 enables BTERM# input. Value of 0 disables BTERM# input. If set to 0, the PCI 9080 bursts four Lword maximum at a time.

bit 8: Memory Space 1 Burst Enable. Value of 1 enables bursting. Value of 0 disables bursting. If burst is disabled, Local Bus performs continuous single cycles for Burst PCI Read/Write cycles.

bit 9: Memory Space 1 Prefetch Disable. If mapped into memory space, value of 0 enables Read prefetching. Value of 1 disables prefetching. If prefetching is disabled, the PCI 9080 disconnects after each memory read.

bit 10: Read Prefetch Count Enable. When set to 1 and memory prefetching is enabled, the PCI 9080 prefetches up to the number of Lwords specified in prefetch count. When set to 0, the PCI 9080 ignores the count and continues prefetching until terminated by PCI Bus.

bit 14:11: Prefetch Counter. Number of Lwords to prefetch during memory Read cycles(0-15).

bit 31:15: Reserved.

### A.3. Runtime Registers

The Mailbox registers and doorbell registers are not used in PCI4520/DM7520, there are no local processor on the board. Therefore the Mailbox Register 0 and 1 can be downloaded from serial EEPROM. The Mailbox Register 0 is used to store the Date of EEPROM content creation in Year/Month/Day format in Hex.

The Interrupt Control /Status Register is described in Interrupt chapter.

Runtime Registers:

| PCI<br>(Offset<br>from Base<br>Address) | PCI<br>Writable | Serial<br>EEPROM<br>Writable | To ensure software compatibility with other versions of the<br>PCI 9080 family and to ensure compatibility with future<br>enhancements, write 0 to all unused bits. |             |
|---|-----------------|------------------------------|---|-------------|
|   |                 |                              | 31  | 0           |
| 40h                                     | Yes             | Yes                          | Mailbox Register 0 (see Note)   |             |
| 44h                                     | Yes             | Yes                          | Mailbox Register 1 (see Note)   |             |
| 48h                                     | Yes             | No                           | Mailbox Register 2 - Not used in PCI4520/DM7520   |             |
| 4Ch                                     | Yes             | No                           | Mailbox Register 3- Not used in PCI4520/DM7520  |             |
| 50h                                     | Yes             | No                           | Mailbox Register 4- Not used in PCI4520/DM7520  |             |
| 54h                                     | Yes             | No                           | Mailbox Register 5- Not used in PCI4520/DM7520  |             |
| 58h                                     | Yes             | No                           | Mailbox Register 6- Not used in PCI4520/DM7520  |             |
| 5C                                      | Yes             | No                           | Mailbox Register 7- Not used in PCI4520/DM7520  |             |
| 60h                                     | Yes             | No                           | PCI-to-Local Doorbell Register  |             |
| 64h                                     | Yes             | No                           | Local-to-PCI Doorbell Register  |             |
| 68h                                     | Yes             | No                           | Interrupt Control / Status  |             |
| 6Ch                                     | Yes             | No                           | Serial EEPROM Control, PCI Command Codes, User I/O<br>Control, Init Control   |             |
| 70h                                     | No              | No                           | Device ID   | Vendor ID   |
| 74h                                     | No              | No                           | Unused  | Revision ID |
| 78h                                     | Yes             | No                           | Mailbox Register 0 (see Note)   |             |
| 7Ch                                     | Yes             | No                           | Mailbox Register 1 (see Note)   |             |

**Note:** Mailbox registers 0 and 1 are always accessible at addresses 78h/C0h and 7Ch/C4. When the I2O feature is disabled (QSR[0]=0), Mailbox registers 0 and 1 are also accessible at PCI Addresses 40h and 44h for PCI 9060 compatibility. When the I2O feature is enabled, the Inbound and Outbound Queue pointers are accessed at addresses 40h and 44h, replacing the Mailbox registers in PCI Address space.

For the Interrupt Control/Status register description see the Chapter of Interrupt.

The only register described here is the Serial EEPROM Control Register.

### A.3.1 Serial EEPROM Control, PCI Command Codes, User I/O Control, Init Control ((CNTRL; PCI:6Ch, no EEPROM loadable)

|      |    |      |    |      |    |      |    |      |    |      |   |      |   |      |   |
|------|----|------|----|------|----|------|----|------|----|------|---|------|---|------|---|
| 31   | 28 | 27   | 24 | 23   | 20 | 19   | 16 | 15   | 12 | 11   | 8 | 7    | 4 | 3    | 0 |
| 0000 |    | 0000 |    | 0000 |    | 0000 |    | 0111 |    | 0110 |   | 0111 |   | 1110 |   |
| 0    |    | 0    |    | 0    |    | 0    |    | 7    |    | 6    |   | 7    |   | E    |   |

**0000767E**

bit 3:0: PCI Read Command Code for DMA. Sent out during DMA Read cycles.

bit 7:4: PCI Write Command Code for DMA. Sent out during DMA Write cycles.

bit 11:8: PCI Memory Read Command Code for Direct Master. Sent out during Direct Master Read cycles.

bit 15:12 PCI Memory Write Command Code for Direct Master. Sent out during Direct Master Write cycles.

bit 16 General Purpose Output. Value of 1 causes USER0 output to go high. Value of 0 causes USER0 output to go low. Not used on PCI4520/DM7520.

bit 17 General Purpose Input. Value of 1 indicates USER1 input pin is high. Value of 0 indicates USER1 pin is low. Not used on PCI4520/DM7520.

bit 23:18 Reserved.

bit 24: Serial EEPROM Clock for Local or PCI Bus Reads or Writes to Serial EEPROM. Toggling this bit generates serial EEPROM clock. (Refer to manufacturer's data sheet for particular serial EEPROM being used.)

bit 25: Serial EEPROM Chip Select. For Local or PCI Bus Reads or Writes to serial EEPROM, setting this bit to 1 provides serial EEPROM chip select.

bit 26: Write Bit to serial EEPROM. For Writes, this output bit is input to serial EEPROM. Clocked into serial EEPROM by serial EEPROM clock.

bit 27: Read Serial EEPROM Data. For Reads, this input bit is output of serial EEPROM. Clocked out of serial EEPROM by serial EEPROM clock.

bit 28: Serial EEPROM Present. Value of 1 indicates serial EEPROM is present.

bit 29: Reload Configuration Registers. When set to 0, writing 1 causes the PCI 9080 to reload Local Configuration registers from serial EEPROM.

bit 30: PCI Adapter Software Reset. Value of 1 holds Local Bus logic in the PCI 9080 reset and LRESETto# asserted. Contents of PCI Configuration registers and Shared Run Time registers are not reset. Software Reset can only be cleared from the PCI Bus. (Local Bus remains reset until this bit is cleared.)

bit 31: Local Init Status. Value of 1 indicates Local Init done. Responses to PCI accesses are Retrys until this bit is set. While input pin NB# is asserted low, this bit is forced to 1.

### A.4. DMA Registers

The DMA registers are described in Chapter 7.

### A.5. LAS0 Register Area

The LAS0 Register Area is described in Chapter 4.

### A.6. LAS1 Register Area

The LAS1 Register Area is described in Chapter 4.

## Appendix B - The PLX9080 EEPROM content

The EEPROM can be programmed in an external programmer or using the Serial EEPROM Control, PCI Command Codes Register.

| Serial EEPROM Offset | Value (Hex) | Description   |
|----------------------|-------------|---|
| 00                   | 4520        | Device ID (7520 or 7540)  |
| 02                   | 1435        | Vendor ID   |
| 04                   | ff00        | PCICCR; Class Code  |
| 06                   | 0000        | PCICCR; Class Code rev.   |
| 08                   | 0000        | Maximum Latency, Minimum Grant,                                 |
| 0A                   | 0100        | Int Pin, Int Routing  |
| 0C                   | 1999        | MSW of Mailbox 0 (EEPROM Content Creation Date)                 |
| 0E                   | 0126        | LSW of Mailbox 0 (EEPROM Content Creation Date)                 |
| 10                   | 0000        | MSW of Mailbox 1  |
| 12                   | 0000        | LSW of Mailbox 1  |
| 14                   | ffff        | MSW of LASORR; Local Address Space 0 Range - 512 byte           |
| 16                   | fe00        | LSW of LASORR; Local Address Space 0 Range - 512 byte           |
| 18                   | 0000        | MSW of LASOBA; Local Address Space 0 Base Address (Re-Map)      |
| 1A                   | 0001        | LSW of LASOBA; Local Address Space 0 Base Address (Re-Map)      |
| 1C                   | 0020        | MSW of MARBR; Mode, Arbitration Register                        |
| 1E                   | 0000        | LSW of MARBR; Mode, Arbitration Register                        |
| 20                   | 0000        | MSW of BIGEND; Big/Little Endian Descrtiptor Register           |
| 22                   | 0000        | LSW of BIGEND; Big/Little Endian Descrtiptor Register           |
| 24                   | 0000        | MSW of EROMRR; Expansion ROM Range                              |
| 26                   | 0000        | LSW of EROMRR; Expansion ROM Range                              |
| 28                   | 0000        | MSW of EROMBA; Expansion ROM Base Address (ReMap)               |
| 2A                   | 0000        | LSW of EROMBA; Expansion ROM Base Address (ReMap)               |
| 2C                   | 4200        | MSW of LBRD0; Local Address Space 0 Bus Region Descriptors      |
| 2E                   | 0143        | LSW of LBRD0; Local Address Space 0 Bus Region Descriptors      |
| 30                   | 0000        | MSW of DMRR; Range Register for Direct Master To PCI            |
| 32                   | 0000        | LSW of DMRR; Range Register for Direct Master To PCI            |
| 34                   | 0000        | MSW of DMLBAM; Base Address Register for Direct Master to PCI   |
| 36                   | 0000        | LSW of DMLBAM; Base Address Register for Direct Master to PCI   |
| 38                   | 0000        | MSW of DMLBAI; Base Addr. Reg. for Direct Master to PCI IO/CFG  |
| 3A                   | 0000        | LSW of DMLBAI; Base Addr. Reg. for Direct Master to PCI IO/CFG  |
| 3C                   | 0000        | MSW of DMPBAM; PCI Base Addr. R. for Dir. Master to PCI (ReMap) |
| 3E                   | 0000        | MSW of DMPBAM; PCI Base Addr. R. for Dir. Master to PCI (ReMap) |
| 40                   | 0000        | MSW of DMCFGA; PCI Conf. Addr. R. for Dir. Master to PCI IO/CFG |
| 42                   | 0000        | LSW of DMCFGA; PCI Conf. Addr. R. for Dir. Master to PCI IO/CFG |
| 44                   | 9080        | Subsystem ID,   |
| 46                   | 10B5        | Subsystem Vendor ID   |
| 48                   | ffff        | MSW of LAS1RR; Local Address Space 1 Range - 16 byte            |
| 4A                   | fff0        | LSW of LAS1RR; Local Address Space 1 Range - 16 byte            |
| 4C                   | 4000        | MSW of LAS1BA; Local Address Space 1 Base Address ReMap         |
| 4E                   | 0001        | MSW of LAS1BA; Local Address Space 1 Base Address ReMap         |
| 50                   | 0000        | MSW of LBRD1; Local Address Space 1 Bus Region Descriptors      |
| 52                   | 01C1        | LSW of LBRD1; Local Address Space 1 Bus Region Descriptors      |
| 54                   | 0000        | MSW of PEROMBA;Expansion ROM PCI Base Address Register          |
| 56                   | 0000        | LSW of PEROMBA;Expansion ROM PCI Base Address Register          |

## **Appendix C - Differences between The PCI4520 and the DM7520, DM7540 boards**

1. The PCI4520 is a PCI slot board, the DM7520 is a PC/104plus board. It means that before you use the DM7520 you must set the rotary switch in the appropriate state before you fit your board in your PC/104plus system. It needs a bus master board position.
2. The DM7520/DM7540 does not have SW1 and SW2 switches of PCI4520. It means that the user should terminate the differential lines externally.
3. The DM7520/DM7540 has no Gain factor 64 and 128.
4. The DM7520/DM7540 has a Master / Target only Jumper. The state of the jumper can be read (Chapter 4.1)  
After Ver8.
5. The DM7520/DM7540 has a 24-bit DAC clock with new DAC clock circuitry.
6. The DM7520/DM7540 has a 20 MHz clock as primary pacer clock source to have finer frequency resolution of pacer clock frequency.
7. The DM7540 has an McBSP serial connection to the SPM6030/6020 board.

## Limited Warranty

Real Time Devices USA, Inc. warrants the hardware and software products it manufactures and produces to be free from defects in materials and workmanship for one year following the date of shipment from REAL TIME DEVICES USA, INC. This warranty is limited to the original purchaser of product and is not transferable.

During the one year warranty period, REAL TIME DEVICES USA will repair or replace, at its option, any defective products or parts at no additional charge, provided that the product is returned, shipping prepaid, to REAL TIME DEVICES USA. All replaced parts and products become the property of REAL TIME DEVICES USA. Before returning any product for repair, customers are required to contact the factory for an RMA number.

THIS LIMITED WARRANTY DOES NOT EXTEND TO ANY PRODUCTS WHICH HAVE BEEN DAMAGED AS A RESULT OF ACCIDENT, MISUSE, ABUSE (such as: use of incorrect input voltages, improper or insufficient ventilation, failure to follow the operating instructions that are provided by REAL TIME DEVICES USA, "acts of God" or other contingencies beyond the control of REAL TIME DEVICES USA), OR AS A RESULT OF SERVICE OR MODIFICATION BY ANYONE OTHER THAN REAL TIME DEVICES USA. EXCEPT AS EXPRESSLY SET FORTH ABOVE, NO OTHER WARRANTIES ARE EXPRESSED OR IMPLIED, INCLUDING, BUT NOT LIMITED TO, ANY IMPLIED WARRANTIES OF MERCHANTABILITY AND FITNESS FOR A PARTICULAR PURPOSE, AND REAL TIME DEVICES USA EXPRESSLY DISCLAIMS ALL WARRANTIES NOT STATED HEREIN. ALL IMPLIED WARRANTIES, INCLUDING IMPLIED WARRANTIES FOR MERCHANTABILITY AND FITNESS FOR A PARTICULAR PURPOSE, ARE LIMITED TO THE DURATION OF THIS WARRANTY. IN THE EVENT THE PRODUCT IS NOT FREE FROM DEFECTS AS WARRANTED ABOVE, THE PURCHASER'S SOLE REMEDY SHALL BE REPAIR OR REPLACEMENT AS PROVIDED ABOVE. UNDER NO CIRCUMSTANCES WILL REAL TIME DEVICES USA BE LIABLE TO THE PURCHASER OR ANY USER FOR ANY DAMAGES, INCLUDING ANY INCIDENTAL OR CONSEQUENTIAL DAMAGES, EXPENSES, LOST PROFITS, LOST SAVINGS, OR OTHER DAMAGES ARISING OUT OF THE USE OR INABILITY TO USE THE PRODUCT.

SOME STATES DO NOT ALLOW THE EXCLUSION OR LIMITATION OF INCIDENTAL OR CONSEQUENTIAL DAMAGES FOR CONSUMER PRODUCTS, AND SOME STATES DO NOT ALLOW LIMITATIONS ON HOW LONG AN IMPLIED WARRANTY LASTS, SO THE ABOVE LIMITATIONS OR EXCLUSIONS MAY NOT APPLY TO YOU.

THIS WARRANTY GIVES YOU SPECIFIC LEGAL RIGHTS, AND YOU MAY ALSO HAVE OTHER RIGHTS WHICH VARY FROM STATE TO STATE.

Real Time Devices USA, Inc.  
P.O. Box 906  
103 Innovation Blvd.  
State College PA 16803  
USA  
Our website: [www.rtdusa.com](http://www.rtdusa.com)