

TS16 Temperature Sensor Board User's Manual

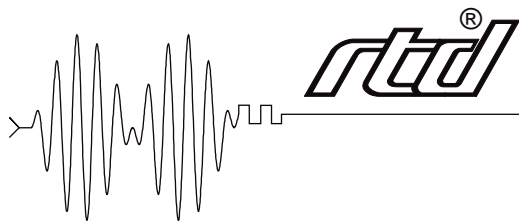

Real Time Devices USA, Inc.

"Accessing the Analog World"™

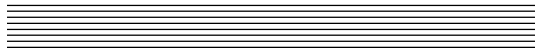

TS16



User's Manual



REAL TIME DEVICES USA, INC.

Post Office Box 906

State College, Pennsylvania 16804

Phone: (814) 234-8087

FAX: (814) 234-5218

Published by
Real Time Devices USA, Inc.
P.O. Box 906
State College, PA 16804

Copyright © 1996 by Real Time Devices, Inc.
All rights reserved

Printed in U.S.A.

Table of Contents

Introduction	i-1
Multiplexing	i-3
What Comes With Your Board	i-3
Using This Manual	i-4
When You Need Help	i-4
Chapter 1 Board Settings	1-1
Factory-Configured Switch and Jumper Settings	1-3
P3 and P4 — A/D Converter Board Channel Select (Factory Setting: Channel 1/GND)	1-4
P5 Through P20 — Ground Return Select (Factory Setting: Return Through 10 Kilohm Resistor)	1-6
P21 — Power Source Select (Factory Setting: Internal)	1-6
Switching Thermocouple Chips	1-6
Chapter 2 Board Connections	2-1
Connecting to the A/D Converter Board	2-3
Connecting to a 50-pin A/D Converter Board	2-3
Connecting to a 40-pin A/D Converter Board	2-3
Connecting to the Signal Sources	2-4
Connecting to Thermocouples	2-6
Chapter 3 Board Operation	3-1
Signal Conditioning Circuitry	3-3
Multiplexing Circuitry	3-3
Input Voltage Range	3-3
Digital Control Lines	3-3
Noise Compensation	3-5
Appendix A TS16 Specifications	A-1
Appendix B Warranty	B-1

Introduction

The TS16 temperature sensor board provides amplification and cold junction compensation for J or K thermocouples. This external interface board features:

- 16 thermocouple input channels,
- J or K thermocouple compatibility,
- Jumper-selectable connection of input return directly to ground for maximum noise immunity,
- Circuit pads to install resistors and capacitors for input signal conditioning,
- Miniature screw terminal blocks for easy input signal connection,
- Extra I/O connector for daisy chaining,
- Connector for external +12 volt power,
- Complete compatibility with RTD's 50-pin data acquisition boards.

The following paragraphs briefly describe the major function of the board. A more detailed discussion of the board is included in Chapter 3, *Board Operation*. The board setup is described in Chapter 1, *Board Settings*.

Multiplexing

Two on-board multiplexers receive up to 16 thermocouple input channels and route them to the selected channel on the A/D converter board. The A/D converter channel to which the inputs are fed is selected using jumpers on the TS16. All programming is done through four digital control lines connected from the A/D converter board to the TS16. The voltage output of the TS16 channels should not exceed the input range of A/D converter board.

Signal Conditioning

The thermocouple output is conditioned by an on-board precision monolithic thermocouple amplifier with cold junction compensation. The AD594 is pretrimmed for type J thermocouples and the AD595 is pretrimmed for type K thermocouples. Both amplifier chips are included with your board and can be exchanged easily since the part is mounted in a socket.

What Comes With Your Board

You receive the following items in your TS16 package:

- TS16 temperature sensor board with AD594 (J type) amplifier installed
- AD595 (K type) amplifier IC
- User's manual

If any item is missing or damaged, please call Real Time Devices' Customer Service Department at (814) 234-8087. If you require service outside the U.S., contact your local distributor.

In addition to the items included in your TS16 package, Real Time Devices offers a full line of board accessories. Key accessories for the TS16 include the XT50 twisted pair flat ribbon cable, TB50 terminal board and XB50 prototype/terminal board which can be connected to the daisy chain connector for prototype development and easy signal access, and the DWK-1 and DWK-2 discrete wire kits for connecting 40-pin A/D converter boards to the 50-pin TS16 board.

Using This Manual

This manual is intended to help you get your new board running quickly, while also providing enough detail about the board and its functions so that you can enjoy maximum use of its features even in the most complex applications. We assume that you already have an understanding of data acquisition principles and that you can provide the software necessary to control the TS16 board.

When You Need Help

This manual provides enough information to properly use your board's features. If you have any problems installing or using this board, contact our Technical Support Department, (814) 234-8087, during regular business hours, eastern standard time or eastern daylight time, or send a FAX requesting assistance to (814) 234-5218. When sending a FAX request, please include your company's name and address, your name, your telephone number, and a brief description of the problem.

Chapter 1 Board Settings

The TS16 board has jumper settings you can change if necessary for your application. The factory settings are listed and shown on a diagram in the beginning of this chapter. Should you need to change these settings, use these easy-to-follow instructions.

Table 1-1: Factory Settings		
Jumper/ Switch	Function Controlled	Factory Setting
P3, P4	Select the channel that the TS16 is connected to on the A/D converter board. One or two jumpers must be installed, as explained later in this chapter.	P3 = Channel 1; P4 = Channel 1 GND
P5-P20	Connects the negative (iron or chromel) side of the thermocouple to ground through a 10 kilohm resistor or directly	Connected to ground through 10 K resistor
P21	Connects the TS16 power to the internal power (supplied from A/D board) or external power (supplied by user).	Connected to internal power

P3 and P4 — A/D Converter Board Channel Select (Factory Setting: Channel 1/GND)

The TS16 allows you to monitor and collect data from up to 16 thermocouples through a single channel on your A/D converter board. P3 and P4 are used to select which analog input channel on your A/D converter board you connect to the TS16. These connectors accommodate A/D converter boards with up to 16 channels.

For Boards With 1-8 Input Channels: When you connect the TS16 to an A/D converter board with eight or fewer analog input channels, P3 is used to set the desired input channel, and P4 is used to set the corresponding ground for that channel. For example, if you place the jumper across the pins for channel 1 on P3, you should place the P4 jumper across the channel 1 ground pins (labeled (1) on the board), as shown in Figure 1-2 below. You must install both jumpers — the selected channel jumper and the corresponding ground jumper — regardless of whether you are operating in the single-ended or differential mode.

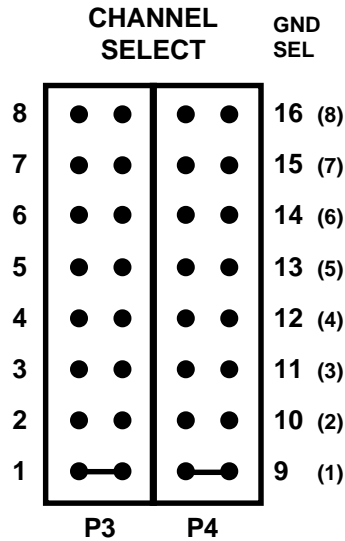

Fig. 1-2 — Channel Select Jumpers, 8-Channel A/D Boards

For Boards With 16 Input Channels (Single-Ended): When you connect the TS16 to an A/D converter board with 16 input channels, only one jumper is installed on P3 and P4. Figure 1-3 shows you how to configure the TS16 for channel 1, and Figure 1-4 shows you how to configure the TS16 for channel 9 when used with a 16-channel A/D converter board. Note that the leftmost row of pins on P3 carries the analog input signal for channels 1 through 8, the rightmost row of pins

on P3 provides the common signal for all 16 channels, and the leftmost row of pins on P4 carries the analog input signal for channels 9 through 16. The rightmost row of pins on P4 is connected to ground and is not used when connecting to a 16-channel A/D converter board.

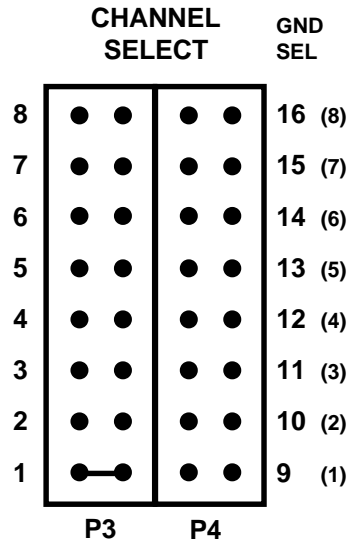

Fig. 1-3 — Connecting Channel 1 to a 16-Channel A/D Board

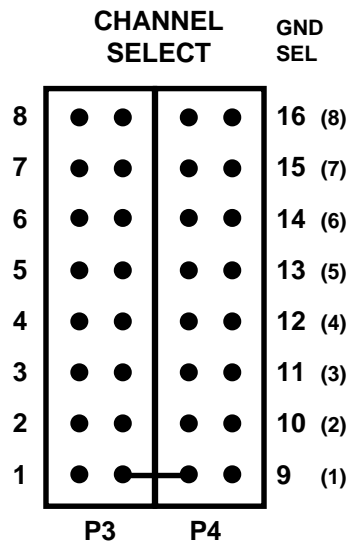

Fig. 1-4 — Connecting Channel 9 to a 16-Channel A/D Board

P5 Through P20 — Ground Return Select (Factory Setting: Return Through 10 Kilohm Resistor)

P5 through P20, shown in Figure 1-5, lets you connect the negative side (iron or chromel side) of the thermocouple to ground through a 10 kilohm resistor or through direct connection. If the thermocouple is not remotely grounded, then the connection should be made to ground through the 10 kilohm resistor (factory setting for all jumpers). If the thermocouple is remotely grounded, then this connection should be made directly to ground for greatest noise immunity.

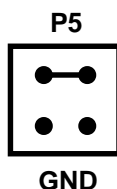

Fig. 1-5 — Ground Return Select Jumper, P5-P20

P21 — Power Source Select (Factory Setting: Internal)

P21 lets you select the power source for the TS16. When the jumper is placed across the INT pins, power is supplied from the +5 volt pin on the A/D board. This will be satisfactory for most applications. If several TS16 boards or other front-end boards such as relay boards are to be connected to the same A/D board or if you suspect that the internal +5 volt supply is causing noisy readings, it is recommended that you power the TS16 from an external +12 volt supply connected to TB4 or J35. These connectors are hooked in parallel and either one can be used to supply the power. If you are using J35, the center pin is the positive connection. An internal +5 volt regulator converts the external +12 volts to the proper voltage for the board. When external power is used, move the jumper on P21 to EXT. J35 is a standard 2.0 mm power connector. Real Time Devices can supply external power supplies to be used with the TS16. Please call for more information on pricing and part numbers.

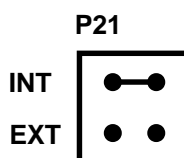

Fig. 1-6 — Power source select, P21

Switching Thermocouple Chips:

The TS16 board has been shipped with the AD594 amplifier installed in the socket at U3. This is the amplifier that you will want to use if you are measuring "J" type thermocouples. If you are trying to measure "K" type thermocouples, you will need to replace the AD594 amplifier with the AD595 amplifier. This chip was shipped along with your board. **NOTE: When replacing the amplifier chip, be careful to insert the chip with the proper pin 1 location. Also be sure to ground yourself to the computer chassis to reduce the risk of static electricity damage.**

Chapter 2 Board Connections

This chapter tells you step-by-step how to connect the TS16 board to your A/D converter board and to your external signal sources.

Connecting to the A/D Converter Board

Connecting to a 50-pin A/D Converter Board

Figure 2-1 shows the TS16's P1 I/O connector pinout, with all of the pins used by the TS16 board labeled. The TS16 is pin-for-pin compatible with all Real Time Devices' 50-pin I/O connector boards. For these boards, all of the unlabeled pins on the TS16 carry the same signal found at the I/O connector of the A/D converter board you are using.

If you want to access other signals on your A/D converter board, such as digital I/O or timer/counters, you can connect to the 16 signals available on TB3 at the top of the TS16 board, shown in Figure 2-2. This terminal strip is labeled with the pin numbers brought out to it from the 50-pin connector. To find the signals available on these pins, refer to the A/D converter board's pinout included in the board's manual.

To further expand your thermocouple monitoring capability by adding more TS16 boards, you can use the daisy chain connector on the TS16 board, P2. The signals at this connector are identical to the pinout of your 50-pin A/D converter board. You can connect to another TS16 board, or to a TB50 or XB50 breakout board to easily access all of the digital I/O and timer/counter signals. Our technical staff will gladly help you select the accessories you need for your application.

WARNING! If you connect more than one TS16 board to an A/D converter board, be sure that you select a different A/D converter board channel for each TS16 board used (header connectors P3 and P4 on the TS16). If you try to connect more than one TS16 to the same channel, damage to the boards and data acquisition system can result!

Connecting to a 40-pin A/D Converter Board

The TS16 can be adapted for use with all Real Time Devices' 40-pin A/D converter boards by making I/O connections using an RTD Discrete Wire Kit. Available with single or twisted pair wiring, this kit is designed so that you can mate connectors with otherwise incompatible pinouts. Using Figure 2-1 and the pinout diagram for your A/D converter board, you can make the appropriate connections.

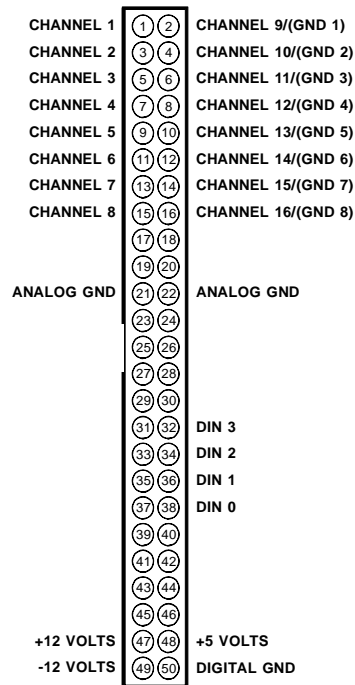

Fig. 2-1 — P1 I/O Connector Pin Assignments

Connecting to the Signal Sources

Figure 2-2 shows TB1 and TB2, where the thermocouple output signals are connected. These 20-terminal miniature screw terminal strips let you easily connect and disconnect analog inputs to the board. Four additional analog ground terminals are provided on each strip for your convenience when connecting signal sources.

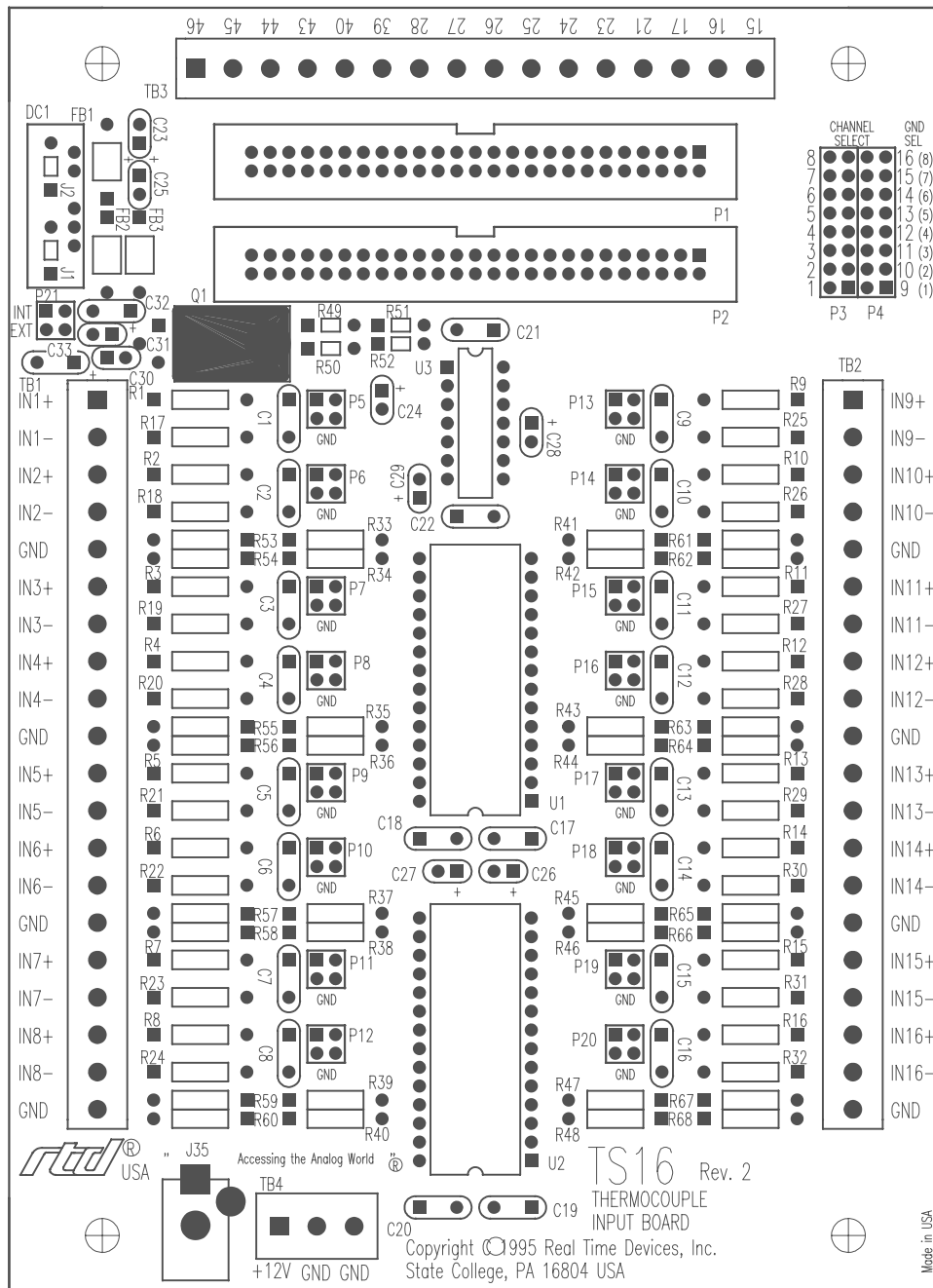

Fig. 2-2 — TS16 Board Layout

Connecting to Thermocouples

Up to 16 thermocouples (all J or all K type) can be connected to the TS16. If the thermocouple is not remotely grounded, then the ground connection on the TS16 should be made through the 10 kilohm resistor installed on the board. This is the factory setting for all 16 inputs (using P5-P20). This connection assures that common mode voltages induced in the thermocouple loop are not converted to normal mode voltages. If a remote ground is provided at the thermocouple, then the input can be connected directly to ground by changing the setting of the corresponding ground return jumper, as described in Chapter 1. Direct connection to ground provides the greatest noise immunity. Figure 2-3 shows you how to make the thermocouple connections.

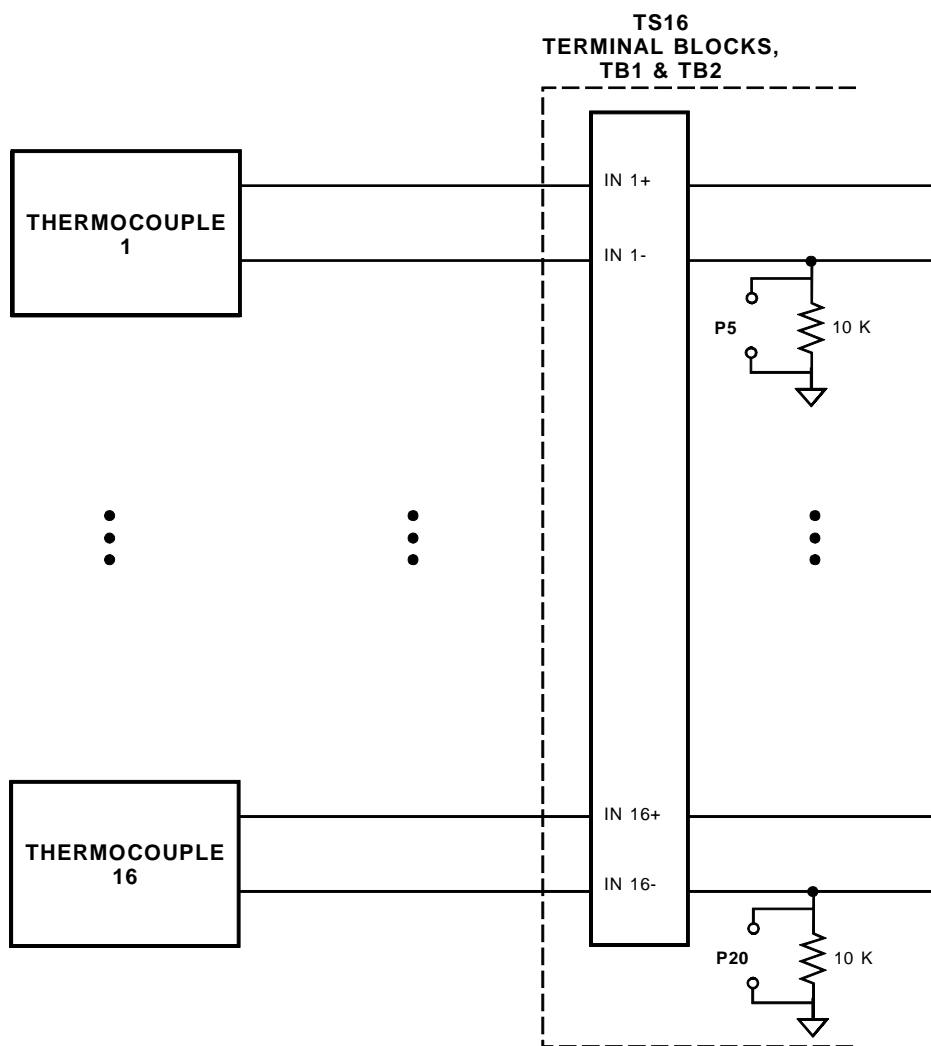

Fig. 2-3 — Thermocouple Connections

Chapter 3 Board Operation

This chapter describes the features of the TS16 and board operation. On-board pads allow the addition of low-pass filtering, as described near the end of the chapter.

The TS16 provides amplification and cold junction compensation for up to 16 J or K type thermocouples and routes them into a single input channel on your A/D converter board.

Multiplexing Circuitry

The TS16 uses two 16-input analog multiplexers to provide a single output which is fed to the selected input channel on an A/D converter board. Each multiplexer has ± 35 Vdc overvoltage protection to protect it against accidental signal overloads.

Input Voltage Range

The input voltage range of the TS16 is determined by the range of the A/D converter board. For example, if the A/D board is set for a ± 5 volt range, then the TS16 board's output should be within the range of ± 5 volts. The A/D board's input voltage range should be selected so that it will accommodate the amplified output range of the thermocouples you are monitoring.

Digital Control Lines

Four digital control lines, DIN0 through DIN3 (or DOUT0 through DOUT3 when looking at the signals output from the A/D converter board), let you select which TS16 channel is active. These lines are programmed from your A/D converter board where they must be configured as digital output lines. The TS16 cannot be controlled by analog lines! If your board's digital I/O is provided by an 8255 programmable peripheral interface (PPI), then you must set up the lines that you use for TS16 channel selection as mode 0 outputs. The A/D converter board manual tells you how to set up the PPI.

Table 3-1 shows the 4-bit digital words and their corresponding channel selections.

Input Channel	DIN Line Setting 3 2 1 0	Input Channel	DIN Line Setting 3 2 1 0
1	0 0 0 0	9	1 0 0 0
2	0 0 0 1	10	1 0 0 1
3	0 0 1 0	11	1 0 1 0
4	0 0 1 1	12	1 0 1 1
5	0 1 0 0	13	1 1 0 0
6	0 1 0 1	14	1 1 0 1
7	0 1 1 0	15	1 1 1 0
8	0 1 1 1	16	1 1 1 1

Signal Conditioning Circuitry

The heart of the temperature sensing circuitry is the AD594 (J type) or AD595 (K type) instrumentation amplifier and cold junction compensator. This precision chip combines an ice point reference with a precalibrated amplifier to provide a high level output of 10 mV/°C directly from the thermocouple signal.

Table 3-2: Output Voltage vs. Thermocouple Temperature (Ambient +25°C, Vs = +12V, -12V)									
Thermocoupl Temp. (°C)	Type J Voltage (mV)	AD594 Output (mV)	Type K Voltage (mV)	AD595 Output (mV)	Thermocoupl Temp. (°C)	Type J Voltage (mV)	AD594 Output (mV)	Type K Voltage (mV)	AD595 Output (mV)
-200	-7.890	-1523	-5.891	-1454	500	27.388	5300	20.640	5107
-180	-7.402	-1428	-5.550	-1370	520	28.511	5517	21.493	5318
-160	-6.821	-1316	-5.141	-1269	540	29.642	5736	22.346	5529
-140	-6.159	-1188	-4.669	-1152	560	30.782	5956	23.198	5740
-120	-5.426	-1046	-4.138	-1021	580	31.933	6179	24.050	5950
-100	-4.632	-893	-3.553	-876	600	33.096	6404	24.902	6161
-80	-3.785	-729	-2.920	-719	620	34.273	6632	25.751	6371
-60	-2.892	-556	-2.243	-552	640	35.464	6862	26.599	6581
-40	-1.960	-376	-1.527	-375	660	36.671	7095	27.445	6790
-20	-.995	-189	-.777	-189	680	37.893	7332	28.288	6998
-10	-.501	-94	-.392	-94	700	39.130	7571	29.128	7206
0	0	3.1	0	2.7	720	40.382	7813	29.965	7413
10	.507	101	.397	101	740	41.647	8058	30.799	7619
20	1.019	200	.798	200	750	42.283	8181	31.214	7722
25	1.277	250	1.000	250	760	-	-	31.629	7825
30	1.536	300	1.203	300	780	-	-	32.455	8029
40	2.058	401	1.611	401	800	-	-	33.277	8232
50	2.585	503	2.022	503	820	-	-	34.095	8434
60	3.115	606	2.436	605	840	-	-	34.909	8636
80	4.186	813	3.266	810	860	-	-	35.718	8836
100	5.268	1022	4.095	1015	880	-	-	36.524	9035
120	6.359	1233	4.919	1219	900	-	-	37.325	9233
140	7.457	1445	5.733	1420	920	-	-	38.122	9430
160	8.560	1659	6.539	1620	940	-	-	38.915	9626
180	9.667	1873	7.338	1817	960	-	-	39.703	9821
200	10.777	2087	8.137	2015	980	-	-	40.488	10015
220	11.887	2302	8.938	2213	1000	-	-	41.269	10209
240	12.998	2517	9.745	2413	1020	-	-	42.045	10400
260	14.108	2732	10.560	2614	1040	-	-	42.817	10591
280	15.217	2946	11.381	2817	1060	-	-	43.585	10781
300	16.325	3160	12.207	3022	1080	-	-	44.349	10970
320	17.432	3374	13.039	3327	1100	-	-	45.108	11158
340	18.537	3588	13.874	3434	1120	-	-	45.863	11345
360	19.640	3801	14.712	3641	1140	-	-	46.612	11530
380	20.743	4015	15.552	3849	1160	-	-	47.356	11714
400	21.846	4228	16.395	4057	1180	-	-	48.095	11897
420	22.949	4441	17.241	4266					
440	24.054	4655	18.088	4476					
460	25.161	4869	18.938	4686					
480	26.272	5084	19.788	4896					

Because the output voltage of the thermocouple is nonlinear with respect to temperature and the AD594/AD595 linearly amplifies the compensated signal, the following transfer functions should be used to determine the actual output voltages:

- Type J voltage = (AD594 output / 193.4) - 16 μ V
- Type K voltage = (AD595 output / 247.3) - 11 μ V

Table 3-2 shows the ideal output voltages for the AD594 and AD595 for selected thermocouple temperatures. These outputs are subject to calibration, gain, and sensitivity errors which must be taken into account in the actual operating environment. Also, note that, because of slightly different alloy content between ANSI (U.S.) type J thermocouples and DIN (European) Fe-CuNi thermocouples, Table 3-2 should not be used in conjunction with European standard thermocouples. Instead, use the transfer function above in conjunction with a DIN thermocouple table to obtain accurate results. This does not apply to type K thermocouples.

To estimate the temperature to within $\pm 0.7^\circ\text{C}$ when the thermocouple output voltage is known (using the formulas given on page 3-3), the following polynomial can be used:

$$T = a_0 + a_1 V + a_2 V^2 + \dots + a_n V^n$$

Where T = temperature in $^\circ\text{C}$, V = the thermocouple output voltage in millivolts, and a_n = the constants from the table below:

	Type J	Type K
a_0	-0.048868252	0.226584602
a_1	19873.14503	24152.10900
a_2	-218614.5353	67233.42488
a_3	11569199.78	2210340.682
a_4	-264917531.4	-860963914.9
a_5	2018441314	4.83506×10^{10}
a_6		-1.18452×10^{12}
a_7		1.38690×10^{13}
a_8		-6.33708×10^{13}

Noise Compensation

Because of the low output voltages from the thermocouples, care should be taken to minimize noise in the thermocouple circuitry. Ways in which you can reduce noise are:

- Locate the TS16 as close as possible to the thermocouple sources. This allows amplification of the thermocouple output before long transmission to the A/D converter board.
- If the thermocouple is remotely grounded, connect the negative (iron or chromel) side directly to ground on the TS16. This is accomplished by placing the jumper on P5-P20 across the bottom pair of pins labeled GND (see Chapter 1).

In addition, circuit pads are provided to install a low-pass filter on the inputs to reduce noise by filtering out harmonics and other undesirable components. Figure 3-1 shows you how to build this circuit.

NOTE: When installing resistors on the board in the locations referenced in the table, **be sure to remove the solder blob** on the bottom side of the board between the two leads of each resistor. Otherwise, the resistor is shorted and has no effect in your circuit!

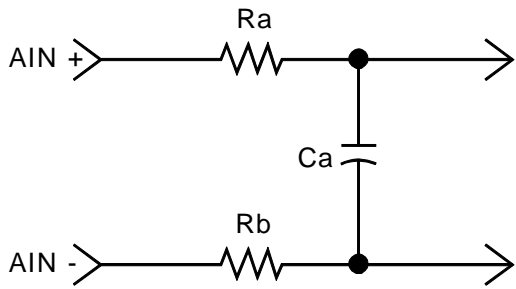

REMOVE SOLDER SHORT ON BOTTOM OF BOARD BETWEEN LEAD PADS FOR Ra AND Rb WHEN INSTALLING RESISTORS ON THE BOARD!

Formula: Frequency = $1/[2\pi(Ra+Rb)Ca]$

Example: Ra = 10 kΩ
 Rb = 10 kΩ
 Ca = 1000 pF

Frequency = $1/2\pi[(10 \times 10^3 + 10 \times 10^3) \times (1000 \times 10^{-12})]$
 Frequency = 7.958 kHz

Channel	Ra	Rb	Ca
1	R1	R17	C1
2	R2	R18	C2
3	R3	R19	C3
4	R4	R20	C4
5	R5	R21	C5
6	R6	R22	C6
7	R7	R23	C7
8	R8	R24	C8
9	R9	R25	C9
10	R10	R26	C10
11	R11	R27	C11
12	R12	R28	C12
13	R13	R29	C13
14	R14	R30	C14
15	R15	R31	C15
16	R16	R32	C16

Fig. 3-1 — Low-Pass Filtering

Appendix A **TS16 Specifications**

TS16 Characteristics Typical @ 25° C**Input Circuitry**

Number of channels	16
Maximum input voltage	±12 Vdc
Overvoltage protection	±35 Vdc

Thermocouple Amplifier AD594/AD595

Thermocouple type	J (AD594) or K (AD595)
Closed loop gain	193.4 (AD594) or 247.3 (AD595)
Output range	±10 Vdc
Output scaling	10 mV/°C
Temperature measurement range	-200 to +1000°C
Calibration error	±3°C
Ambient temperature range	0 to +50°C

Power Requirements

+5 volts (Internal Power)	+80 mA
+12 volts (External Power)	+40 mA

Connectors

Two 50-pin shrouded headers with ejector tabs

Screw Terminals

TB1 and TB2 - 20-terminal; TB3 - 16-terminal; TB4 - 3-terminal
22-12 AWG wire

Size

6.875"L x 5.0"W (175mm x 127mm)

Appendix B Warranty

LIMITED WARRANTY

Real Time Devices, Inc. warrants the hardware and software products it manufactures and produces to be free from defects in materials and workmanship for one year following the date of shipment from REAL TIME DEVICES. This warranty is limited to the original purchaser of product and is not transferable.

During the one year warranty period, REAL TIME DEVICES will repair or replace, at its option, any defective products or parts at no additional charge, provided that the product is returned, shipping prepaid, to REAL TIME DEVICES. All replaced parts and products become the property of REAL TIME DEVICES. **Before returning any product for repair, customers are required to contact the factory for an RMA number.**

THIS LIMITED WARRANTY DOES NOT EXTEND TO ANY PRODUCTS WHICH HAVE BEEN DAMAGED AS A RESULT OF ACCIDENT, MISUSE, ABUSE (such as: use of incorrect input voltages, improper or insufficient ventilation, failure to follow the operating instructions that are provided by REAL TIME DEVICES, "acts of God" or other contingencies beyond the control of REAL TIME DEVICES), OR AS A RESULT OF SERVICE OR MODIFICATION BY ANYONE OTHER THAN REAL TIME DEVICES. EXCEPT AS EXPRESSLY SET FORTH ABOVE, NO OTHER WARRANTIES ARE EXPRESSED OR IMPLIED, INCLUDING, BUT NOT LIMITED TO, ANY IMPLIED WARRANTIES OF MERCHANTABILITY AND FITNESS FOR A PARTICULAR PURPOSE, AND REAL TIME DEVICES EXPRESSLY DISCLAIMS ALL WARRANTIES NOT STATED HEREIN. ALL IMPLIED WARRANTIES, INCLUDING IMPLIED WARRANTIES FOR MERCHANTABILITY AND FITNESS FOR A PARTICULAR PURPOSE, ARE LIMITED TO THE DURATION OF THIS WARRANTY. IN THE EVENT THE PRODUCT IS NOT FREE FROM DEFECTS AS WARRANTED ABOVE, THE PURCHASER'S SOLE REMEDY SHALL BE REPAIR OR REPLACEMENT AS PROVIDED ABOVE. UNDER NO CIRCUMSTANCES WILL REAL TIME DEVICES BE LIABLE TO THE PURCHASER OR ANY USER FOR ANY DAMAGES, INCLUDING ANY INCIDENTAL OR CONSEQUENTIAL DAMAGES, EXPENSES, LOST PROFITS, LOST SAVINGS, OR OTHER DAMAGES ARISING OUT OF THE USE OR INABILITY TO USE THE PRODUCT.

SOME STATES DO NOT ALLOW THE EXCLUSION OR LIMITATION OF INCIDENTAL OR CONSEQUENTIAL DAMAGES FOR CONSUMER PRODUCTS, AND SOME STATES DO NOT ALLOW LIMITATIONS ON HOW LONG AN IMPLIED WARRANTY LASTS, SO THE ABOVE LIMITATIONS OR EXCLUSIONS MAY NOT APPLY TO YOU.

THIS WARRANTY GIVES YOU SPECIFIC LEGAL RIGHTS, AND YOU MAY ALSO HAVE OTHER RIGHTS WHICH VARY FROM STATE TO STATE.

