

HESC-SER Manual

***High Efficiency & Smart Charging* Vehicle Power Supply DC to DC Convertor**

Manufactured by
TRI-M ENGINEERING

Engineered Solutions for Embedded Applications

Technical Manual

P/N: HESC-SER-MAN-V1

Revision: 04/02

Unit 6, 1301 Ketch Court
Coquitlam, British Columbia, V3K 6X7
Canada
<http://www.Tri-M.com>
Tel 604.527.1100 - North America 800.665.5600
Fax 604.527.1110

PREFACE

This manual is for integrators of applications of embedded systems. It contains information on hardware requirements and interconnection to other embedded electronics.

DISCLAIMER

Tri-M Engineering makes no representations or warranties with respect to the contents of this manual, and specifically disclaims any implied warranties of merchantability or fitness for any particular purpose. Tri-M Engineering shall under no circumstances be liable for incidental or consequential damages or related expenses resulting from the use of this product, even if it has been notified of the possibility of such damages. Tri-M Engineering reserves the right to revise this publication from time to time without obligation to notify any person of such revisions. If errors are found, please contact Tri-M Engineering at the address listed on the title page of this document.

COPYRIGHT © 2000-03-22 TRI-M ENGINEERING

No part of this document may be reproduced, transmitted, transcribed, stored in a retrieval system, or translated into any language or computer language, in any form or by any means, electronic, mechanical, magnetic, optical, chemical, manual, or otherwise, without the express written permission of Tri-M Engineering.

CHAPTER 1 - INTRODUCTION

1.1 GENERAL DESCRIPTION

The HESC-SER is a high efficiency, high performance DC to DC 60 watt converter that supplies +5V, -5V, +12V & -12V outputs. The HESC-SER also includes a flash based microcontroller that supplies advanced power management, smart battery charger and an RS232 serial port. The HESC-SER is designed for low noise embedded computer systems, has a wide input range of 6-40V(>6:1) and is ideal for battery or unregulated input applications. The HESC-SER is specifically designed for vehicular applications and has heavy-duty transient suppressors (5000W) that clamp the input voltage to safe levels, while maintaining normal power supply operation.

The HESC-SER is a state-of-the-art mosfet based design that provides outstanding line and load regulation with efficiencies up to 95 percent. Organic Semiconductor Capacitors provide filtering that reduces ripple noises below 20mV. The low noise design makes the HESC-SER ideal for use aboard aircraft or military applications or wherever EMI or RFI must be minimized. The +5VDC and +12VDC outputs are controlled by a constant off-time current-mode architecture regulator that provides excellent line and load transient response.

The HESC-SER provides up to four stages of battery charging and can charge Lead-Acid, NiCd, and NiMH batteries and is also SMBus level 3 compatible. Charge currents are up to 4A, and battery charging voltages from 9.5 to 35V.

The HESC-SER has advanced power management functions that allows timed on/off control of the HESC-SER, notification of changes to main power and changes in the battery status. For example, the HESC-SER can be programmed to power off it's outputs in 60 seconds, then turn on again 12 hours later.

The HESC-SER size is 3.55 x 3.775 inches which is the same size as the PC/104 standard, and has the same mounting holes pattern as the PC/104 standard. However, the HESC-SER does not supply the PC/104 bus connectors. (For a PC/104 fully compliant power supply, please see the Tri-M Engineering HESC104.) All generated voltages are provided to a Phoenix header. A removable plug allows the HESC-SER to be easily installed. The RS232 serial port is provided on a 2x5 row pin header.

The HESC-SER can be configured to meet almost any power supply and battery charging need for embedded applications, whether that be a simple +5V application, or providing power for back lighted LCD panels, or a full UPS (un-interruptible power supply configuration).

1.2 FEATURES

- DC to DC converter for embedded applications.
- “Load Dump” transient suppression on input power supply.
- Operates from 6VDC to 40VDC input.
- PC/104 size and mounting holes.
- 60 watt power supply outputs.
- 5V, 12V, -12V, -5V, and battery charger outputs.
- Temperature range -40 to 85C.
- Monitors up to 16 external temperatures using I2C digital temperature sensors.
- RS232 serial port for setup, monitoring and control.
- Optocoupled inputs for ignition, and system "shut-down" pushbutton.

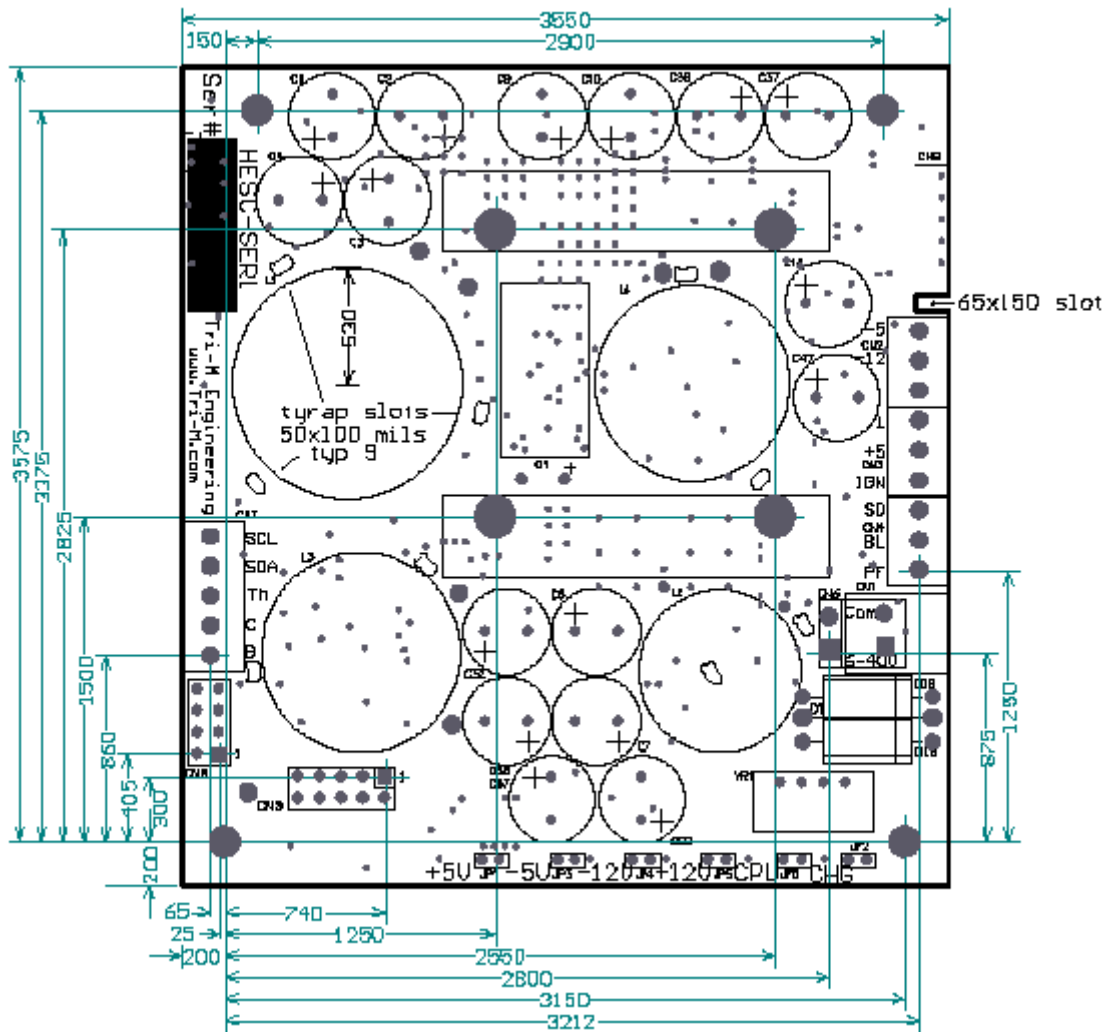

1.3 SPECIFICATIONS

Power Supply Specifications	
Model	HESC-SER
5V output*	12 A
12V output	2.5 A
-5V output	400mA
-12V output	500mA
Input Voltage Range	6 to 40V
Load Regulation **	<60mV
Line Regulation **	±40mV
Output temp. drift **	<40mV
Switching Freq.	75kHz
Max. Input Transient	125V for 100msec
Output Ripple**	<20mV
Conducted Susceptibility **	>57db
Efficiency**	up to 95%
Temp Range	-40 to 85C
Quiescent current***	2mA
Size, PC/104 form factor compliant****	3.55"W. x 3.75"L x 0.6"Height

*Current rating includes current supplied to 12V, -12V, & -5V regulators.

**Measured on the 5V output.

***LEDs disabled,

CHAPTER 2 - CONFIGURATION AND INSTALLATION

2.1 Introduction

This chapter describes the configuration and installation of the HESC-SER power supply. In addition, section 2.2 provides a formula to calculate the available +5VDC. Figure 2-1 shows the HESC-SER connectors, jumpers and other options.

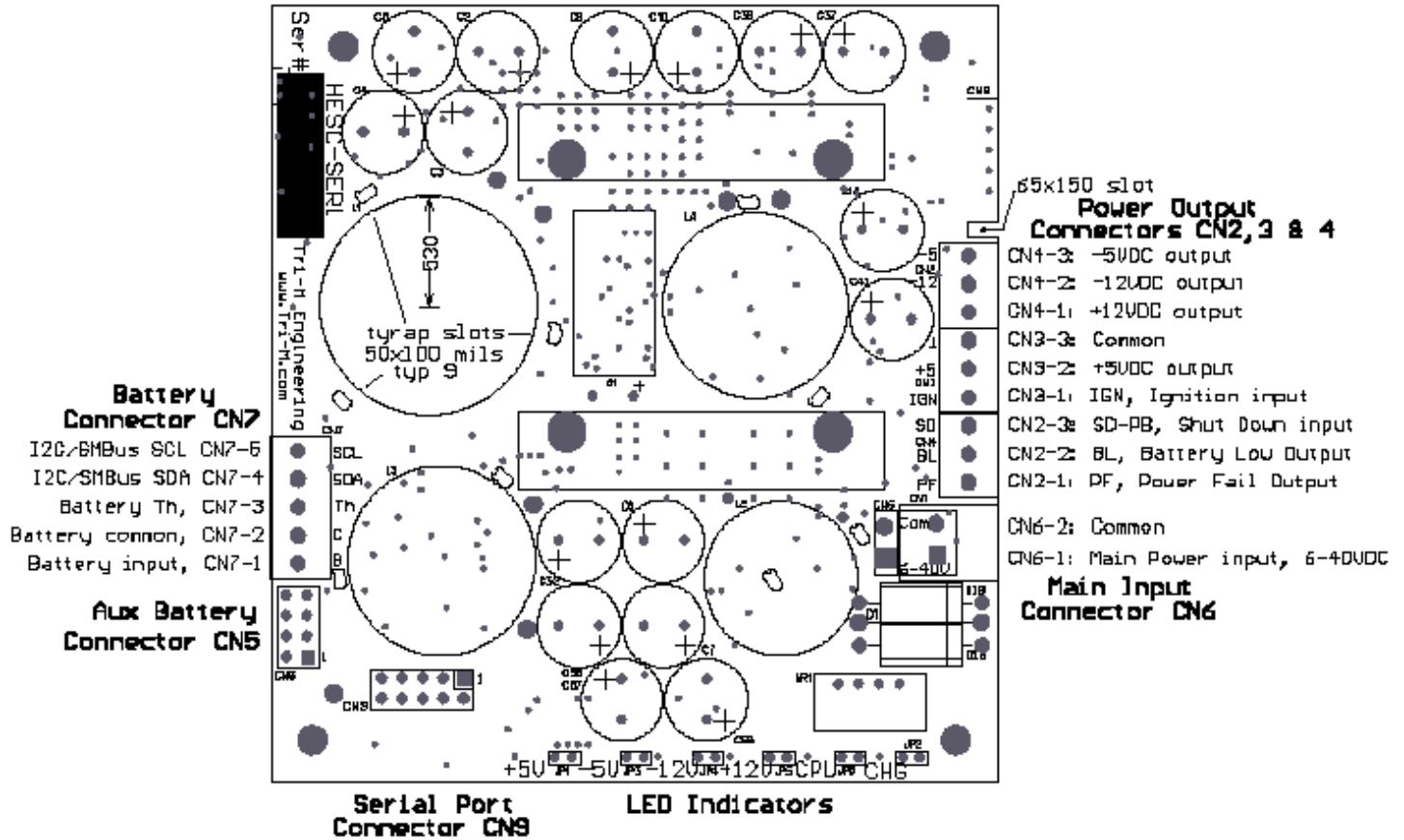

2.2 Power Considerations.

The +5V switching regulator is rated at 12A maximum output, however the +5V output supplies power to the +12, -5, and -12VDC regulators. To obtain the usable range of +5V output, “derate” according to the use of +12, -5, and -12VDC. Use the following formulae to calculate the maximum usable output.

$$Usable + 5V output = 12 A - \frac{(I[-5] + I[-12] * 2.4 + I[12] * 2.4)}{0.9}$$

Where: $I[-5]$ = -5VDC current load
 $I[-12]$ = -12VDC current load
 $I[12]$ = 12VDC current load

Assuming 90 percent converter efficiency (actual efficiency may vary).

2.3.1 Main Input Power Connector

Input power is connected to the HESC-SER by a “Molex” plug and pin connector CN6. The power supply accepts DC input voltages in the range of 6VDC to 40VDC.

Unregulated vehicle power is connected as follows:

- Terminal 1: “hot” polarity
- Terminal 2: Common (0VDC)

2.3.2 Output Power Connector

Output power is available for use via Phoenix MiniCombicon connector. Connectors CN2, CN3 & CN4 are immediately side by side, with a nine position mating plug-in mating header supplied

- CN4-1: Position 1, PF (Power Fail signal output) TTL logic level
- CN4-2: Position 2, BL (Battery Low signal output) TTL logic level
- CN4-3: Position 3, SD-PB (Shut Down input, ie push button input) 4-12V DC
- CN3-1: Position 4, IGN (Ignition input, ie maintained contact closure) 4-12V DC
- CN3-2: Position 5, +5VDC output
- CN3-3: Position 6, common
- CN2-1: Position 7, +12VDC output
- CN2-2: Position 8, -12VDC output
- CN2-3: Position 9, -5VDC output

Note: All outputs are active low. The active state of the IGN signal is programmable by using SCU utility.

2.3.3 Battery Connector

Batteries are connected via the Phoenix MiniCombicon connector, CN7. The HESC-SER accepts DC battery voltages in the range 6.5V to 35VDC through the Battery Power Connector.

- CN7-1: Battery Positive
- CN7-2: Common
- CN7-3: TH, thermistor/safety input
- CN7-4: SDA, I2C/SMBus data input/output signal
- CN7-5: SCL, I2C/SMBus clock input/output signal

2.3.4 Aux Battery Connector

Tri-M Engineering battery packs such as the BAT104-NiCd, BAT104-NiMh, BAT104-SLA25 and BAT104-SLA45 can be directly plugged into the HESC-SER through connector CN5. Connector CN5 is a two row by four pin header, with the BAT104 battery packs having a mating female connector.

- CN5-1: Battery Positive
- CN5-2: Common
- CN5-3: Battery Positive
- CN5-4: Common
- CN5-5: SDA, I2C/SMBus data input/output signal
- CN5-6: SCL, I2C/SMBus clock input/output signal
- CN5-7: +5VC, +5V for digital temperature sensor and battery enable
- CN5-8: BE, Battery Enable output

2.3.5 RS232 Serial Port Interface

The HESC-SER provides an RS232 serial port for remote control, monitoring and datalogging. The serial port connector is a two row by five pin header connector, CN9.

- CN9-1: BL, Battery Low signal output (TTL level)
- CN9-2: Not used
- CN9-3: TX-Out, RS232 output signal
- CN9-4: Not used
- CN9-5: RX-IN, RS232 input signal
- CN9-6: PF-232, Power Fail signal output, RS232 signal levels
- CN9-7: SD-232, Shut Down signal input, RS232 signal levels
- CN9-8: Not used
- CN9-9: Common
- CN9-10: Common

2.6 Jumper Selection

This section describes the function of each jumper, the location of it, the default setting, and how to change it.

2.6.1 LED Jumper Enable/Disable

These jumpers allow the LEDs to be disabled. This is most likely to be used when absolute minimum power consumption must be maintained, such as when operating off a limited battery source.

The location of each LED jumper shown in the diagram below.

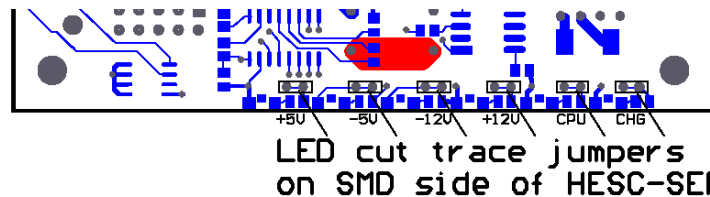

Each LED is enabled by factory default. To disable any LED, remove the LED jumper (or cut the small PCB trace if no jumper is installed) associated with the LED. To re-enable any LED, re-install the associated jumper (or solder a short jumper wire between each of the jumper pads).

3.1 Using HESC104 Power Management Features.

Note: In order to activate power management features, HESC-SER must be upgraded with UPS Firmware.

By monitoring and activating the following inputs and outputs, the HESC-SER power supply is capable of responding to changes in input supply and battery voltage to alert the host CPU of such conditions. To help accomplishing this task with ease, TRI-M provides a Windows based Smart Charger Utility (SCU). This utility is also required when changing the charge profile for different batteries or future firmware update.

- CN4-1: Position 1, PF (Power Fail signal output)
- CN4-2: Position 2, BL (Battery Low signal output)
- CN4-3: Position 3, SD-PB (Shut Down input, ie push button input)
- CN3-1: Position 4, IGN (Ignition input, ie maintained contact closure)

IGN and SD response to 4-12V DC input as logic high. It can be triggered on either low or high level of input. The input polarity is set by changing one of the Charger flag. Figure 3-1 is a snap-shot of the SCU utility page which shows the charger flags. When the flag is unchecked, SD and IGN react to logic high input and vice-versa with flag checked.

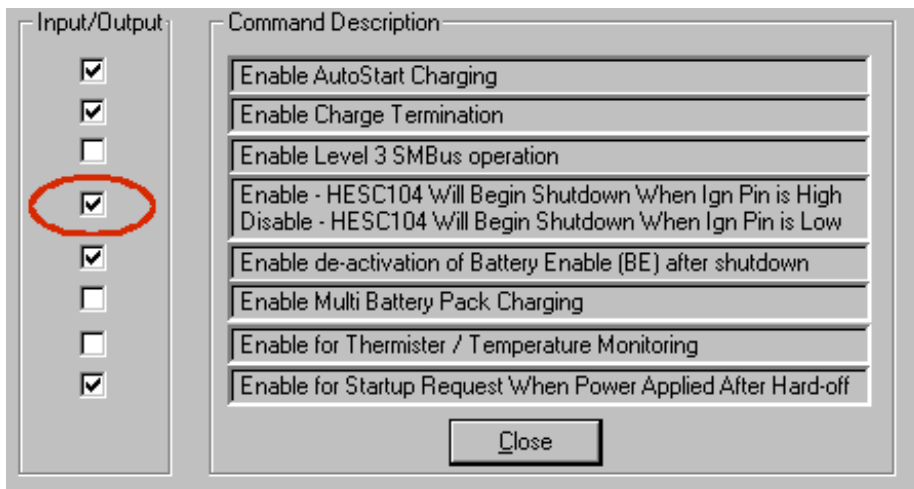

Figure 3-1

BL is driven low when the battery voltage is below the setpoint value of Minimum Battery Operating Voltage EEPROM variable. Figure 3-2 shows this variable under the OTHER EEPROM SETPOINTS page. Please note the unit of 9400 is in millivolt.

Input/Output	Range/Units	Command Description
Ch Flags	Setup	Charger / Power Supply Enable Flags
9400	0.65535 / Sec	Minimum Battery Operating Voltage
2	0.65535 / Sec	Minimum Battery Operating Capacity
7500	0.65535 / 10mW	Maximum Input Power Allowed
0	0.255 / Ticks	Maximum Time Before Communications Timeout
2	Cycle	Define How Many Charge Cycles to Use
281.2	0.6553.5 / 0.1K	Minimum Battery Charging Temperature
318.2	0.6553.5 / 0.1K	Maximum Battery Charging Temperature
65535	0.65535 / mV	Minimum Battery Charging Voltage
0	0.16 / Bits	Define Which I2C Battery Temp Device to Use, 0=Thermister
0	0.16 / Bits	Define Which I2C Ambient Temp Device to Use, 0=Thermister
2	0.65535 / Sec	Rate at Which I2C Devices Are Polled
Temp Sel	Setup	Enables Polling for Selected I2C Device
		Future Use
		Future Use
		Future Use

Update Progress

Read Write Close

Figure 3-2

PF is driven active high when the HESC-SER Main Input shutdown counter starts counting down after main input is removed.

IGN, SD, BL and PF can be used to signal the host CPU to prepare for shutdown. It is critical that operating system such as Linux and Window to be shutdown gracefully otherwise catastrophic consequence may result.

The following diagram summarizes the various input conditions which generate shutdown command to the HESC-SER. After 1 of the 4 signals (BL, PF, SD, IGN) becomes active, the corresponding counter will start counting down to zero. When the counter reaches zero, a shutdown command is issued to switch off the HESC-SER outputs immediately.

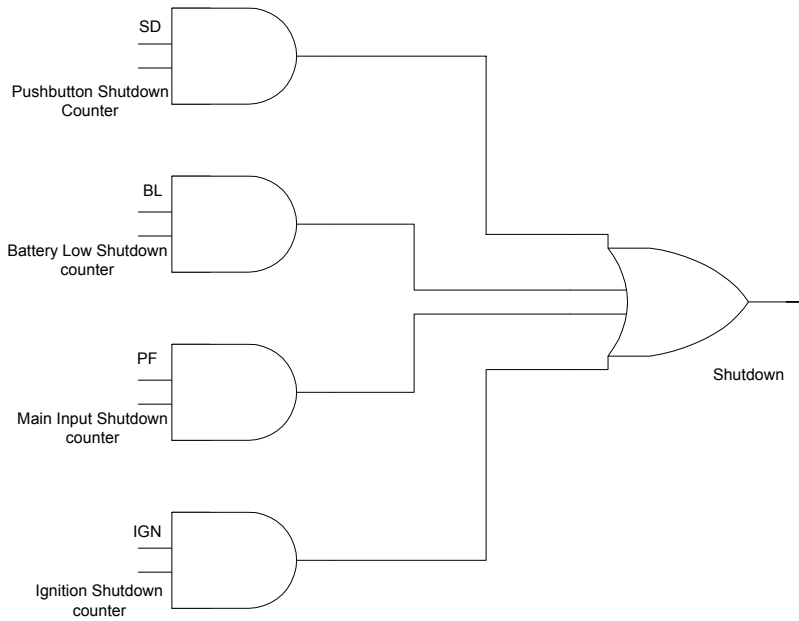

Figure 3-3

Figure 3-4 shows the various counters that are associated with BL, PF, IGN and SD signal to generate shutdown command. These counters are found under the EEPROM UPS SETTINGS page of the SCU utility.

Input/Output	Range/Units	Command Description
5	0..65535 / Sec	Main Power Shut Down Debounce Counter
5	0..65535 / Sec	Main Power Start Up Debounce Counter
5	0..65535 / Sec	Main Power Shut Down Counter
5	0..65535 / Sec	Main Power Start Up Counter
5	0..65535 / Sec	Ignition Shut Down Debounce Counter
5	0..65535 / Sec	Ignition Start Up Debounce Counter
5	0..65535 / Sec	Ignition Shut Down Counter
5	0..65535 / Sec	Ignition Start Up Counter
5	0..65535 / Sec	Push Button Shut Down Counter
5	0..65535 / Sec	Push Button Start Up Counter
5	0..65535 / Sec	Battery Low Shut Down Counter
0	0..65535 / Sec	Power Supply Status Command Shut Down Counter
0	0..65535 / Sec	Power Supply Status Command Start Up Counter

Update Progress

Read Write Close

Figure 3-4