

NuPRO-840 DV/LV
Full-Size PICMG, mPGA478 Pentium 4,
Intel 845 DDR with SiS305 and Gigabit LAN
Single Board Card
User's Guide



Recycle Paper

© Copyright 2001 ADLINK Technology Inc.

All Rights Reserved.

Manual Rev. 1.00: August 1, 2002

Part Number: 50-13030-100

The information in this document is subject to change without prior notice in order to improve reliability, design and function and does not represent a commitment on the part of the manufacturer.

In no event will the manufacturer be liable for direct, indirect, special, incidental, or consequential damages arising out of the use or inability to use the product or documentation, even if advised of the possibility of such damages.

This document contains proprietary information protected by copyright laws. All rights are reserved. No part of this manual may be reproduced by any mechanical, electronic, or other means in any form without prior written permission of the manufacturer.

Trademarks

NuPRO® is a registered trademark of ADLINK Technology Inc. Other product names mentioned herein are used for identification purposes only and may be trademarks and/or registered trademarks of their respective companies.

Getting service from ADLINK

- Customer Satisfaction is the most important priority for ADLINK Tech Inc. If you need any help or service, please contact us.

ADLINK Technology Inc.			
Web Site	http://www.adlinktech.com		
Sales & Service	Service@adlinktech.com		
Technical Support	NuDAQ + USBDAQ	nudaq@adlinktech.com	
	Automation	automation@adlinktech.com	
	NuIPC	nuipc@adlinktech.com	
	NuPRO / EBC	nupro@adlinktech.com	
TEL	+886-2-82265877	FAX	+886-2-82265717
Address	9F, No. 166, Jian Yi Road, Chungho City, Taipei, 235 Taiwan.		

- Please email or FAX us of your detailed information for a prompt, satisfactory and constant service.

Detailed Company Information			
Company/Organization			
Contact Person			
E-mail Address			
Address			
Country			
TEL		FAX	
Web Site			
Questions			
Product Model			
Environment to Use	OS: Computer Brand: M/B: CPU: Chipset: BIOS: Video Card: Network Interface Card: Other:		
Detail Description			
Suggestions to ADLINK			

Table of Contents

Tables	iv
Figures.....	v
Introduction.....	1
Product Description.....	1
Features	2
Functional Blocks and Main Board.....	3
<i>Functional Block</i>	<i>3</i>
<i>Main Board.....</i>	<i>4</i>
<i>Intel Pentium 4 Processor.....</i>	<i>5</i>
<i>Memory.....</i>	<i>5</i>
<i>PCI-to-ISA Bridge.....</i>	<i>5</i>
<i>Dual Ethernet Interfaces.....</i>	<i>6</i>
<i>VGA Interface.....</i>	<i>6</i>
<i>IDE Hard Drive.....</i>	<i>6</i>
<i>Serial I/O.....</i>	<i>6</i>
<i>Interrupts</i>	<i>7</i>
<i>DMA</i>	<i>7</i>
<i>Real-Time Clock.....</i>	<i>7</i>
<i>Watchdog Timer.....</i>	<i>8</i>
<i>IEEE-1284 Parallel Port/Printer Interface.....</i>	<i>8</i>
<i>Universal Serial Bus (USB).....</i>	<i>8</i>
<i>IDE Controller and Floppy Interface Controller.....</i>	<i>8</i>
<i>Keyboard/Mouse Controller.....</i>	<i>9</i>
<i>Software.....</i>	<i>9</i>
Getting Started.....	10
Unpacking	10
System Requirements	11
<i>Electrical and Environmental.....</i>	<i>11</i>
<i>Memory Configuration.....</i>	<i>12</i>
<i>I/O Configuration.....</i>	<i>13</i>
<i>BIOS Configuration Overview.....</i>	<i>14</i>
<i>Operating System Installation.....</i>	<i>15</i>

Configuration.....	16
Switch and Jumper Pins.....	16
<i>Switch Description.....</i>	<i>17</i>
Reset.....	18
Reset Types and Sources.....	18
<i>Hard Reset Sources.....</i>	<i>18</i>
<i>Soft Reset Sources.....</i>	<i>18</i>
System Monitoring and Alarms.....	20
SMBus Address Map.....	20
Chassis Intrusion.....	20
IDE Controller.....	21
Features of the IDE Controller.....	21
Disk Drive Support.....	21
<i>IDE Channel.....</i>	<i>21</i>
I/O Mapping.....	22
Device Drivers.....	22
Watchdog Timer.....	23
Watchdog Timer Overview.....	23
<i>Watchdog Timer Architecture.....</i>	<i>23</i>
Using the Watchdog in an Application.....	24
<i>Watchdog Reset.....</i>	<i>24</i>
Driver Installation.....	27
Intel 845D Chipset Hardware Configuration File Installation.....	27
<i>Installing Hardware Configuration Files.....</i>	<i>28</i>
VGA Driver Installation.....	29
<i>Installing Drivers for Windows 98/ME/NT/2000.....</i>	<i>29</i>
LAN Driver Installation.....	31
<i>Driver Installation on Windows 2000/XP.....</i>	<i>31</i>
<i>Driver Installation on Windows 98/98SE/ME.....</i>	<i>31</i>
<i>Driver Installation on Windows NT.....</i>	<i>32</i>

Specifications	33
Electrical	33
Environment	35
Mechanical	36
<i>Board Dimensions.....</i>	<i>36</i>
Jumpers & Connectors	37
<i>Clear CMOS Jumper – JP1.....</i>	<i>39</i>
<i>VGA Connector – CN9.....</i>	<i>39</i>
<i>Keyboard/Mouse Connector – CN17.....</i>	<i>39</i>
<i>LAN1 RJ-45 Connector – CN13.....</i>	<i>40</i>
<i>LAN1 LED status.....</i>	<i>40</i>
<i>10/100/1000 LAN2 RJ45 Connector – CN22</i>	<i>40</i>
<i>LAN2 LED status.....</i>	<i>41</i>
<i>SMBus Connector – CN8.....</i>	<i>41</i>
<i>AC'97 Connector – CN6.....</i>	<i>41</i>
<i>Dual USB Connector – CN11.....</i>	<i>42</i>
<i>COM1 and COM2 Pin Header – CN4 & CN2.....</i>	<i>42</i>
<i>Floppy Connector – CN5.....</i>	<i>44</i>
<i>Primary IDE Connector– CN1.....</i>	<i>45</i>
<i>Secondary IDE Connector– CN3.....</i>	<i>46</i>
<i>FAN Connector – FN1, FN2, FN3.....</i>	<i>47</i>
<i>IrDA Connector – CN10.....</i>	<i>47</i>
<i>Thermal Connector – CN12.....</i>	<i>47</i>
<i>Front-Panel Header – CN16.....</i>	<i>48</i>
<i>External Keyboard Connector – CN18.....</i>	<i>49</i>
<i>CASE Open Connector – JP2.....</i>	<i>49</i>
NuPRO-840 Comparison Table	50
Warranty Policy.....	51

Tables

Table 1:	Power consumption with P4-2.4GHz and 1024MB RAM...	11
Table 2:	Memory Address Map Example.....	12
Table 3:	I/O Address Map.....	13
Table 4:	Switch Cross-Reference Table.....	16
Table 5:	JP1 (Clear CMOS Content).....	17
Table 6:	SMBus Slave Devices.....	20
Table 7:	Cross-reference table for figure 6.....	38
Table 8:	Clear CMOS Jumper.....	39
Table 9:	VGA Connector Pin Assignment.....	39
Table 10:	Pinout of PS/2 connector.....	39
Table 11:	Pinout of LAN1 RJ-45.....	40
Table 12:	LAN LED status.....	40
Table 13:	Pin Definition of Gigabit LAN2 RJ-45.....	40
Table 14:	LAN2 LED status.....	41
Table 15:	Pin Assignment of SMBus Connector.....	41
Table 16:	Pinout of AC'97 Connector.....	41
Table 17:	Pin Assignment of the USB Connector.....	42
Table 18:	COM Connector Pin Assignment.....	42
Table 19:	Pin Assignment of Parallel Port Connector.....	43
Table 20:	Pin Assignment of FDD Connector.....	44
Table 21:	Pin Assignment of Primary IDE Connector.....	45
Table 22:	Pin Assignment of Secondary IDE Connector.....	46
Table 23:	Pinout of the Fan Connector.....	47
Table 24:	Pinout of the Fan Connector.....	47
Table 25:	Pinout of the Thermal Connector.....	47
Table 26:	Pinout of the Front Panel Header.....	48
Table 27:	Pinout of the External Keyboard Connector.....	49
Table 28:	Pinout of the Fan Connector.....	49
Table 29:	NuPRO-840 Comparison table.....	50

Figures

Figure 1:	NuPRO-840 Functional Block Diagram	3
Figure 2:	Main Board Diagram	4
Figure 3:	BIOS Setup Screen.....	14
Figure 4:	Location of Jumpers.....	16
Figure 5:	Watchdog Timer Architecture.....	23
Figure 6:	Board Dimensions	36
Figure 7:	Location items on the NuPRO-840.....	37

How to Use This Guide

This manual is intended for users of the NuPRO-840 SBC as a source of information to setup and maintain a working system. This manual gives the user information on specifications, connector types and how to install the different drivers to keep the system running at its optimum level. The manual is divided into 8 chapters with appendixes:

- Chapter 1, “Introduction”**, introduces the key features of the NuPRO-840. This chapter includes a product definition, a list of product features, and a functional block diagram with a brief description of each block
- Chapter 2, “Getting Started”**, provides setup information for the NuPRO-840. This chapter summarizes what you need to know in order to configure your system and should be read before attempting to use the board.
- Chapter 3, “Configuration”**, discusses the configurable jumpers on the NuPRO-840. This chapter details factory default settings and provides information about tailoring the board to the needs of specific applications.
- Chapter 4, “Reset”**, discusses the reset types and reset sources on the NuPRO-840.
- Chapter 5, “System Monitoring and Alarms”**, explains how to access various system-monitoring devices and alarming functions on the NuPRO-840.
- Chapter 6, “IDE Controller”**, provides an introduction to the cPCI-NuPRO-840's IDE Controller. This chapter covers drive configuration, IDE I/O mapping, device drivers, and the NuPRO-840's support for internal and external disk drives.
- Chapter 7, “Watchdog Timer”**, explains the operation of the NuPRO-840's watchdog timer. A sample code is provided to illustrate how the watchdog's functions are used in an application.
- Chapter 8, “Driver Installation”**, provides step-by-step instructions how to install the software drivers successfully.
- Appendix A, “Specifications”**, contains electrical, environmental, and mechanical specifications for the NuPRO-840.
- Appendix B, “Jumpers & Connectors,”** outlines all the jumpers and connectors on the NuPRO-840 and its pin definition
- Appendix C, “NuPRO-840 Comparison Table”**, lists the differences between the different models of the NuPRO-840.

Introduction

This chapter provides an introduction to the NuPRO-840 including a product definition, a list of product features, product specifications and a functional block diagram with a description of each block. The “NuPRO-840 faceplate” illustration shows the on-board I/O accessible from the front of the CPU board.

Unpacking information and initial board configuration instructions are provided in Chapter 2, “Getting Started.” See Chapter 3, “Configuration,” for configuration details and Appendix A, “Specifications,” for detail specification of the NuPRO-840.

Product Description

The NuPRO-840 Pentium 4 Full Size PICMG CPU Card incorporates the Intel advanced 845 Chipset Memory Controller Hub and supports the 478-pin Intel Pentium 4 processors of 1.3GHz and up to 2GHz. This CPU card represents the perfect choice for those who want superior performance for rugged and demanding applications in industrial automation, image processing, multimedia and telecommunications.

The NuPRO-840 CPU card is designed for the highest level of computing performance yet available on SBC's. It features 400MHz front side bus, UltraDMA/100 IDE data transfers, and up to 2GB of DDR SDRAM support that delivers 1GB/s of memory bandwidth. The NuPRO-840 features a SIS305 3D graphics engine with 16MB Video Memory.

This single board computer also offers flexibility with 2 USB ports, Dual LAN 82562 and 82540 Gigabit LAN, watchdog timer, ISA High Drive and PCI to ISA bridge. The NuPRO-840 uses the advanced Intel 845 Chipsets, which is a 100% software compatible chipset with PCI 2.1 standard.

Features

- Fully compliant to PCI rev. 2.2 standards.
- Intel mPGA478 Socket Pentium 4 FC-PGA2 CPU processor.
- Supports Front Side Bus frequency of 400MHz.
- Intel 82845 DDR chipset.
- Up to 2GB DDR SDRAM system memory.
- Support PIO Mode 3/4 and Ultra DMA/33/66/100 IDE devices
- One Floppy drive Port supports both legacy 34-pin header and compact FDD connector.
- Two USB ports with 2x4 pin header.
- Two 16550A compatible serial ports.
- One PS/2 Keyboard port combine PS/2 Mouse port with Y-cable.
- High-speed bi-directional SPP/ECP/EPP parallel port.
- IrDA port with 1x5 pin header.
- Programmable watchdog timer.
- Hardware Monitoring.
- One 10BaseT/100BaseTx Ethernet interfaces (Intel 82562EM), WFM 2.0 compliance.
- One 10BaseT/100BaseTx/1000Base Ethernet interface (Intel 82540EM).

Functional Blocks and Main Board

The following topics provide an overview of the NuPRO-840's main features as shown in the functional block diagram below and also the main board.

Functional Block

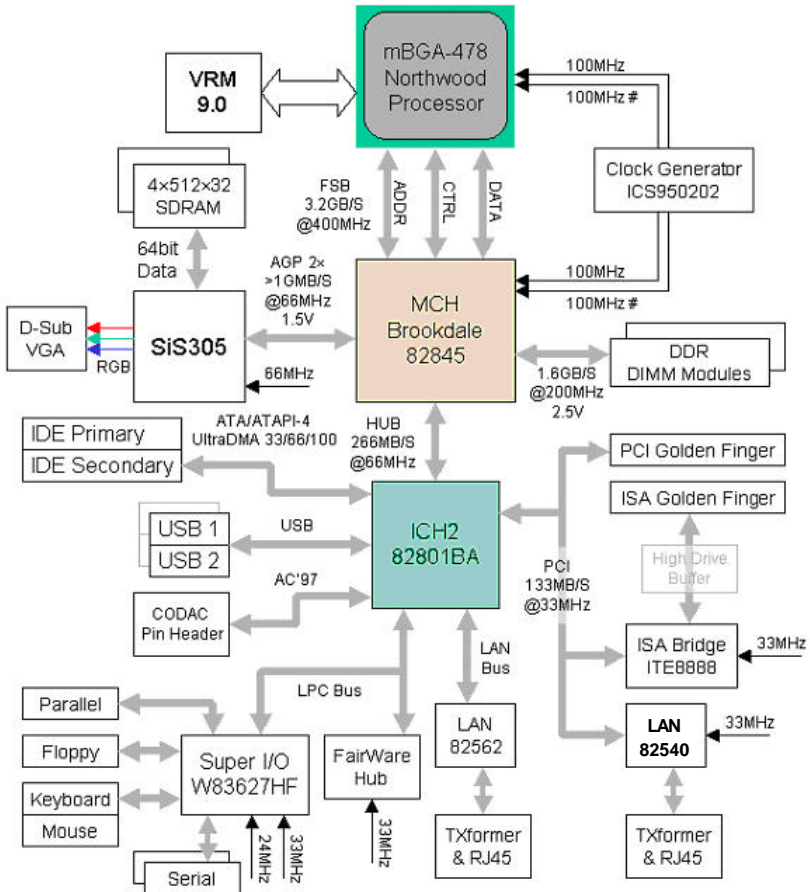

Figure 1: NuPRO-840 Functional Block Diagram

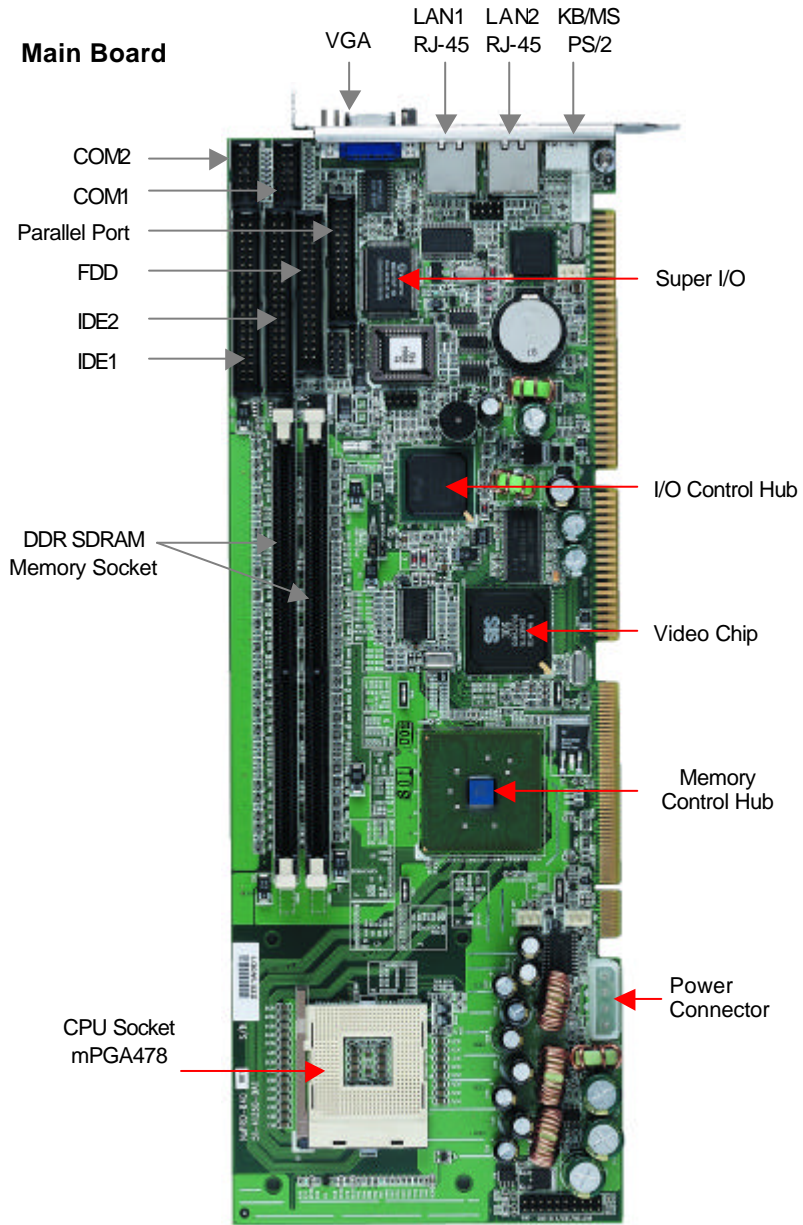

Figure 2: Main Board Diagram

Intel Pentium 4 Processor

The Pentium 4 processor in the 478-pin package is the next generation IA-32 processor. This processor has a number of features that significantly increase its performance with respect to previous generation IA-32, it includes the 400 MHz system bus, and an execution trace cache. The hyper-pipelined technology doubles the pipeline depth in the Pentium 4 processor in the 478-pin package, allowing the processor to reach much higher core frequencies (up to 2GHz). It also features the advanced transfer cache, which is a 256 KB, on-die level 2 Cache with an increased bandwidth over previous micro-architectures.

Memory

NuPRO-840 supports DDR SDRAM memory. The entire memory array may be configured as either standard (un-buffered) DDR SDRAM or buffered SDRAM. The memories speed, type and size can be determined by the BIOS reading the DIMM presence detect bits on the SMBus (System Management Bus). The NuPRO-840 supports up to 2GB of DDR SDRAM memory with two 184-pin DDR DIMM sockets. The NuPRO-840 supports 2.5 Volt single-sided or double-sided DIMMs. DDR SDRAM operations up to 200MHz are supported.

PCI-to-ISA Bridge

The NuPRO-840 features one ITE8888 PCI-to-ISA bridge. The IT8888 serves as a bridge between the PCI bus and ISA bus. The IT8888's 32-bit PCI bus interface is compliant with PCI Specification V2.1 and supports both PCI Bus Master & Slave.

Special features of the ITE8888 include:

- PCI Specification V. 2.1 compliant
- Supports 32-bit PCI bus & up to 33 MHz PCI bus frequency
- Single 33 MHz Clock Input

Dual Ethernet Interfaces

NuPRO-840 provides one 10/100Mbps and one Gigabit Ethernet interface. The Ethernet interface is supplied via the Intel 82562EM chip and Intel 82540EM chip, which are connected to the 82801BA. Each Ethernet interface is routed to an RJ45/LED all in one Connector on the rear panel. Each LAN port consists of both the Media Access Controller (MAC) and the physical layer (PHY) interface combined into a single component solution. LED drive signals for Ethernet link status and activity are routed to the same connector. The integrated Ethernet controller enabling/disabling depends on the existence of 82540EM. The onboard Ethernet is Wired For Management 2.0 compliance. This port is available on the rear panel.

VGA Interface

The NuPRO-840 provides standard SVGA analog output on the rear IO panel. The video function is provided via the SiS305 chipset. The BIOS can be configured through the CMOS setup to disable the onboard video, this allows a PCI video to be the primary video controller and allow memory to be reclaimed for other applications without having to add another video card.

IDE Hard Drive

The NuPRO-840 includes two on-board Enhanced IDE 40-pin headers to support up to 4 IDE devices. The hard drive that is connected on the NuPRO-840's primary IDE channel is assigned "device 0" (master) identity.

Serial I/O

The NuPRO-840 provides support for two 16C550 UARTS serial ports. Both of these serial ports are available via the 10-pin header on-board. The serial ports include a complete set of handshaking and modem control signals, maskable interrupt generation, and data transfer rates up to 115.2K Baud. COM1 and COM2 serial port are RS-232 compatible. The NuPRO-840 serial controller resides in the Winbond W83627HF Super I/O device.

Interrupts

Two enhanced interrupt controllers provide the NuPRO-840 with a total of 15 interrupt inputs. Interrupt controller features include support for:

- Level-triggered and edge-triggered inputs
- Individual input masking
- Fixed and rotating priorities

Interrupt sources include:

- Counter/Timers
- Serial I/O
- Keyboard
- Printer Port
- Floppy disk
- IDE interface
- Real-Time Clock
- On-board PCI devices

Enhanced capabilities include the ability to configure each interrupt level for active high going edge or active low-level inputs. The NuPRO-840's interrupt controllers reside in the Intel 82801BA (ICH2)

DMA

Two enhanced DMA controllers are provided on the NuPRO-840 for use by the onboard peripherals. The NuPRO-840's DMA controllers reside in the Intel 82801BA (ICH2) device.

Real-Time Clock

The real-time clock performs timekeeping functions and includes 256 bytes of general purpose, battery-backed, CMOS RAM. Timekeeping features include an alarm function, a maskable periodic interrupt, and a 100-year calendar. The system BIOS uses a portion of this RAM for BIOS setup information. The NuPRO-840's Real-Time Clock resides in the Intel 82801BA (ICH2) device.

Watchdog Timer

The watchdog timer optionally monitors system operation and can be programmed for different timeout periods (from 1 seconds to 255 seconds or 1 minute to 255 minutes). It is a two-stage watchdog, meaning that it can be enabled to produce a non-maskable interrupt (NMI) or a "CPU init" before it generates a Reset. Failure to strobe the watchdog timer within the programmed time period may result in an NMI, a reset request, or both. A register bit can be enabled to indicate if the watchdog timer caused the reset event. This watchdog timer register is cleared on power-up, enabling system software to take appropriate action if the watchdog generated the reboot. See Chapter 7, "Watchdog Timer," for more information, including a sample code.

IEEE-1284 Parallel Port/Printer Interface

The parallel I/O interface signals are routed to a 26-pin header on the board. This port supports the full IEEE-1284 specifications and provides the basic printer interface.

Firmware will initialize the parallel port as LPT1 with ISA I/O base address of 378h. This default configuration also assigns the parallel port to IRQ7. The printer interface mode (Normal, Extended, EPP, or ECP) is selectable through the BIOS SETUP utility with the Winbond W83627HF Super I/O device managing the NuPRO-840's parallel port.

Universal Serial Bus (USB)

The Universal Serial Bus (USB) provides a common interface to slower-speed peripherals. Functions such as keyboard, serial ports, printer port, and mouse ports can be consolidated into USB, simplifying the cabling requirements of computers. The NuPRO-840 provides two USB ports pin headers (CN11) and is controlled by the Intel 82801 (ICH2) device.

IDE Controller and Floppy Interface Controller

The NuPRO-840 includes an IDE Controller (in the ICH2) and a Floppy Disk Controller (in the W83627HF). The IDE Controller provides support for internal or external IDE drives. Signals are available at the IDE connectors CN1 and CN3 and are routed to a 40-pin header. The FDD Controller provides support for an external FDD drives. Signals are available at the FDD connector CN5 and are routed to a 34-pin header.

Keyboard/Mouse Controller

The NuPRO-840 includes an on-board PC/AT keyboard and mouse controller. The keyboard/mouse signals are available through the PS/2 circular DIN on the rear panel. Both the keyboard and mouse can be connected at the same time using ADLINK's Y cable. An extra connector is available for connection of an external keyboard or mouse (CN18). The NuPRO-840's keyboard/mouse controller resides in the Winbond W83627HF Super I/O device

Software

The NuPRO-840 includes the ADLINK NuPRO Embedded BIOS loaded in on-board flash. The BIOS is user-configurable to boot an operating system from local flash memory, a fixed or floppy drive, or over a network.

The NuPRO-840 is compatible with all major PC operating systems. ADLINK provides support, which may include additional drivers for ADLINK peripherals. Software device drivers for the NuPRO-840 may be found in the ADLINK CD.

Getting Started

This chapter summarizes the information needed to make the NuPRO-840 operational. This chapter should be read before using the board.

Unpacking

Check the shipping carton for any damages. If the shipping carton and contents are damaged, notify the dealer for a replacement. Retain the shipping carton and packing material for inspection by the dealer. Obtain authorization before returning any product to ADLINK.

Check the following items are included in the package, if there is any missing items, contact your dealer:

- The NuPRO-840 module
- This User's Manual
- ADLINK CD

Note: The package of the NuPRO-840 OEM version (non-standard configuration, functionality or package) may vary according to the different configuration requests

CAUTION: This board must be protected from static discharge and physical shock. Never remove any of the socketed parts except at a static-free workstation. Use the anti-static bag shipped with the product to handle the board. Wear a wrist strap grounded through one of the system's ESD Ground jacks when servicing system components.



System Requirements

The following topics briefly describe the basic system requirements and configurable features of the NuPRO-840.

Electrical and Environmental

Power Consumption

The values below are the measured power consumption for the SBC with CPU and RAM only; the CPU is running under 100% loading. The power for other peripheral devices such as keyboard, mouse, add-on cards, HDD, and CD-ROM are not included. The system configuration includes: NuPRO-840DV, Intel Pentium 4 / 2.4GHz, 512MB DDR SDRAM × 2.

CPU	Voltage	Current	Wattage	Note
P4-2.4 GHz with 1024MB RAM	+5.0V	5.24A	26.20W	
	+12V (CPU)	4.46A	53.52W	
	+12V (System)	400mA	4.80W	1
	-12V	100mA	1.20W	
Total Watts=26.20+53.52+4.80+1.20=85.72W				

Table 1: Power consumption with P4-2.4GHz and 1024MB RAM

Note:

1. This includes the CPU fan current, which is approximately 200mA

The NuPRO-840 is supplied with a cooling fan allowing the processor to operate between 0° and approximately 60° C ambient. It is the users' responsibility to ensure that the NuPRO-840 is installed in a chassis capable of supplying adequate airflow. The maximum power dissipation of the processor at 2.4 GHz is 54W. External airflow **must** be provided at all times. ADLINK has special designed chassis to allow for greater airflow, please contact ADLINK sale representatives for more detail.

CAUTION: The processor "core" temperature must **never** exceed 100°C under any condition of ambient temperature or usage. This may result in permanent damage to the processor.



Memory Configuration

The NuPRO-840 addresses up to 4 GB of memory. The address space is divided between memory local to the board and memory located on the Local PCI (or CompactPCI) bus. Any memory not reserved or occupied by a local memory device (DRAM/flash) is available to PCI memory devices.

The NuPRO-840 can also include up to 2 GB DDR SDRAM installed onto the board. 256 KB of L2 cache is integrated with the Pentium 4 processor.

The "Memory Address Map illustration is shown below for the NuPRO-840.

Memory Address Map Example

FFE00000 - FFFFFFFF	High BIOS Area	4 GB
FEE01000 - FFFDFFFF	PCI	4 GB - 2 MB
FEE00000 - FEEFFFFFFF	Local APIC Configuration Space	4GB - 18 MB - 2 MB
40000000 - FEDFFFFFFF	PCI	3 GB + 127 MB + 296 KB
00100000 - 3FFFFFFF	Extended Memory	1 GB + 48 MB + 576 KB
000F0000 - 000FFFFFFF	System BIOS Area	1024 KB
000E0000 - 000EFFFFF	Extended System BIOS Area	960 KB
000C0000 - 000DFFFFF	Expansion Area	896 KB
000A0000 - 000BFFFFF	Video Buffer Area	768 KB
00000000 - 0009FFFFF	DOS Application Area	640 KB
		0

Table 2: Memory Address Map Example

I/O Configuration

The NuPRO-840 addresses up to 64 KB of I/O using a 16-bit I/O address. The NuPRO-840 is populated with many commonly used I/O peripheral devices. The I/O address location for each peripheral is shown in the "I/O Address Map" shown below.

0000 – 001F	82801BA DMA channels 0-3
0020 – 002D	82801BA Interrupt Controller 1
002E – 002F	LPC Super I/O Configuration
0030 – 003D	82801BA Interrupt Controller 1
0040 – 0043	82801BA – Timer/Counter
004E – 004F	LPC Super I/O Configuration
0050 – 0053	82801BA – Timer/Counter
0060,62,64,66	Keyboard Controller
0061,63,65,67	82801BA - NMI Controller
0070 – 0077	82801BA RTC
0080 – 0091	82801BA DMA Page Register
0092	82801BA Port 92 Register
0093 – 009F	82801BA DMA controller
00A0 – 00B1	82801BA Interrupt Controller 2
00B2 – 00B3	APM reserved
00B4 – 00B5	82801BA Interrupt Controller 2
00B8 – 00B9	82801BA Interrupt Controller 2
00BC – 00BD	82801BA Interrupt Controller 2
00C0 – 00DF	82801BA DMA, channels 4-7
0100 – 0107	Super I/O General Purpose I/O
00F0	82801BA FERR#/IGNNE#/Interrupt Controller
0170 – 0177	Secondary IDE Channel
01F0 – 01F7	Primary IDE Channel
0295	83627HF index port
0296	83627HF data port
02F8 – 02FF	COM2
0376	Secondary IDE Channel Command Port
0377	Secondary IDE Channel Status Port
0378 – 037F	LPT1
03F0 – 03F5	Floppy
03F6	Primary IDE Channel Command Port
03F7 – 7	Floppy Disk Change Channel 1
03F7 – 6:0	Primary IDE Channel Status Port
03F7 (write)	Floppy Channel 1 Command
03F8 – 03FF	COM1
04D0 – 04D1	Interrupt Controller Edge/Level Register
0CF8	PCI CONFADD (DWORD Access Only)
0CF9	Reset Generator
0CFA – 0CFB	PCI CONFADD (DWORD Access Only)
0CFC – 0CFF	PCI CONFDATA
FF00 – FF07	IDE Bus Master Register
FFA0 – FFA7	Primary Bus Master IDE Registers
FFA8 – FFAF	Secondary Bus Master IDE Registers
FF80 – FF9F	USB

Table 3: I/O Address Map

BIOS Configuration Overview

This topic presents an introduction to the Phoenix Award PnP BIOS Setup Utility. For more detailed information about the BIOS and other utilities, see the BIOS Manual.

The BIOS has many separately configurable features. These features are selected by running the built-in Setup utility. System configuration settings are saved in a portion of the battery-backed RAM in the real-time clock device and are used by the BIOS to initialize the system at boot up or reset. The configuration is protected by a checksum word for system integrity.

To access the Setup utility, press the "Del" key during the system RAM check at boot time. When Setup runs, an interactive configuration screen displays. Refer to the following "Setup Screen" illustration below for an example.

BIOS Setup Screen

STANDARD CMOS SETUP	INTEGRATED PERIPHERALS
BIOS FEATURES SETUP	SUPERVISOR PASSWORD
CHIPSET FEATURES SETUP	USER PASSWORD
POWER MANAGEMENT SETUP	IDE HDD AUTO DETECTION
PNP/PCI CONFIGURATION	SAVE & EXIT SETUP
LOAD BIOS DEFAULTS	EXIT WITHOUT SAVING
LOAD SETUP DEFAULTS	
ESC : Quit	↑ ↓ → ← : Select Item
F10 : Save & Exit Setup	(Shift) F2 : Change Color
Time, Date, Hard Disk Type	

Figure 3: BIOS Setup Screen

Setup parameters are divided into different categories. The available categories are listed in a menu. The parameters within the highlighted (current) category are listed in the bottom portion of the Setup screen. Context sensitive help is displayed in the right portion of the screen for each parameter.

Use the arrow keys to select a category from the menu. To display a submenu, highlight the category and then press the "Enter" key.

Operating System Installation

For more detailed information about your operating system, refer to the documentation provided by the operating system vendor.

1. Install peripheral devices. Most devices are automatically configured by the BIOS during the boot sequence.
2. Most operating systems require initial installation on a hard drive, from a floppy or CDROM drive. These devices should be configured, installed, and tested with the supplied drivers before attempting to load the new operating system.
3. Read the release notes and installation documentation provided by the operating system vendor. Be sure to read any *README* files or documents provided on the distribution disks, as these typically note documentation discrepancies or compatibility problems.
4. Select the appropriate boot device order in the SETUP boot menu depending on the OS installation media used. For example, if the OS includes a bootable installation floppy, select **Floppy** as the first boot device and reboot the system with the installation floppy installed in the floppy drive. (Note that if the installation requires a non-bootable CD-ROM, it is necessary to boot an OS with the proper CD-ROM drivers in order to access the CD-ROM drive).
5. Proceed with the OS installation as directed, being sure to select appropriate device types if prompted. Refer to the appropriate hardware manuals for specific device types and compatibility modes of ADLINK NuPRO products.
6. When installation is complete, reboot the system and set the boot device order in the SETUP boot menu appropriately.

3

Configuration

The NuPRO-840 has been designed for maximum flexibility and can be configured for specific applications. Most configuration options are selected through the BIOS Setup utility (discussed in the "BIOS Configuration Overview" topic in Chapter 2). Some options cannot be software controlled and are configured with jumpers.

Switch and Jumper Pins

The NuPRO-840 contains a pin-header on the component side of the board. The jumper is listed and briefly described in the "Switch Cross-Reference" table below.

Switch Cross-Reference Table

Jumper	Function
CN16 (pin 15 & 16)	Reset
JP1	Clear CMOS Content

Table 4: Switch Cross-Reference Table



Figure 4: Location of Jumpers

Switch Description

CN16 Reset (Pin 15 & 16)

NuPRO-840 has a circuit that monitors system power and provides the PWROK signal to the 82801BA. This circuit distributes the reset to the rest of the board by generating the CPU, PCI and IDE resets. This board also can be reseted by an external switch that is connected to an onboard header. Reset is discussed in more detail in Chapter 4.

JP1 (Clear CMOS Content)



JP1	Setting	Function
	Pin 1-2 Short/Closed	Normal Operation
	Pin 2-3 Short/Closed	Clear CMOS Content

Table 5: JP1 (Clear CMOS Content)

If the CMOS contents need to be cleared, short pins 2 and 3 of JP1 and return it to normal operation position after about 2 seconds.

Reset

This chapter discusses the reset types and reset sources on the NuPRO-840. If necessary, the NuPRO-840's board reset characteristics can be tailored to the requirements of a specific system.

Reset Types and Sources

The NuPRO-840's reset types are listed below. The sources for each reset type are detailed in the following topics.

- **Hard Reset:** All devices are held in reset.
- **Soft Reset:** CPU initialization only. Other devices are not reset.

Hard Reset Sources

System Register CF9h (ICH2 Reset Control Register)

Bits 1 and 2 in this register are used by the ICH2 to generate a hard reset or a soft reset. During a hard reset, the ICH2 asserts CPURST, PCIRST#, and RSTDRV, and resets its core and suspend all logic.

Soft Reset Sources

System Register CF9h (ICH2 Reset Control Register)

Bits 1 and 2 in this register are used by the ICH2 to generate a hard reset or a soft reset. During a soft reset, the ICH2 asserts INIT to the CPU. This causes the processor to enter "real mode", initialize its internal registers, and begin instruction execution from FFFFFFF0h (the boot vector).

Keyboard CTRL-ALT-DEL

Simultaneously pressing these keys calls a BIOS function that reboots the system.

Note: This method does not work under operating systems that trap calls to this BIOS function.

Watchdog Timer

The watchdog timer may be programmed to generate a "CPU Init" if it is not strobed within a given time-out period. This function is discussed in "Watchdog Timer", Chapter 7.

System Monitoring and Alarms

The NuPRO-840 performs system monitoring and alarming functions using the flexible, industry standard System Management Bus (SMBus). The SMBus is based on I²C serial bus architecture and consists of a two-wire interface and an alert signal. The SMBus allows two-way communication between intelligent on-board and system devices. Each device has an associated address on the bus and may interrupt the processor using the alert signal.

The SMBus controller is located within the ICH2 chip. In addition to the ICH2 chip, there are several slave devices that reside on the SMBus also. These devices and their addresses are listed below:

SMBus Address Map

The table below lists the location, function, and address of each SMBus slave device used on the NuPRO-840.

Address	Function	Device
1010000	Identification Info	DIMM0
1010001	Identification Info	DIMM1
0101101	Control and Status	83627HF
Inside LAN ID	Control and Status	Ethernet # 1

Table 6: SMBus Slave Devices

Chassis Intrusion

NuPRO-840 implements a chassis intrusion circuit that can latch a chassis intrusion event even when the system is turned off, as long as battery or standby power is still present. The chassis intrusion interrupt is fed into the 83627HF hardware monitor chip. The chassis intrusion circuit can only be reset via software using SMI# Mask Register 2 as described in the 83627HF data sheet.

6

IDE Controller

The NuPRO-840's IDE controller provides two IDE channels for interfacing with up to four IDE devices. The IDE controller is incorporated into the Intel ICH2 (82801BA) chipset, which uses the Peripheral Component Interconnect (PCI) bus to provide exceptional IDE performance. The IDE controller can sustain a maximum transfer rate of 100 MB per second between the IDE drive buffer and the PCI bus.

Features of the IDE Controller

- Primary and Secondary channels for interfacing up to four devices
- IBM-AT compatible
- Supports PIO and Bus Master IDE
- "Ultra DMA/33/66/100" Synchronous DMA Operation
- Bus Master IDE transfers up to 100 MB/sec.
- Individual software control for each IDE channel
- 32-bit, 33 MHz, high performance PCI bus interface

Disk Drive Support

The NuPRO-840 supports internal and external IDE devices. These configurations are described below.

IDE Channel

The NuPRO-840's IDE channel is directed to IDE connectors CN1 and CN3. Connector CN1 is used to connect to the primary drive, while Connector CN3 is secondary and allows cabling to an IDE device, such as a CD-ROM drive, installed elsewhere in the system.

I/O Mapping

The I/O map for the IDE interface varies depending on the mode of operation. The default mode is "compatibility mode," meaning that the interface uses the PC-AT legacy addresses of F0h-1F7h, with 3F6h and interrupt IRQ14 for the primary channel. The secondary channel uses I/O addresses 170h-177h, 376h and interrupt IRQ15. No memory addresses are used.

Device Drivers

The IDE interface works with all applications by default. To fully utilize the IDE interface, additional software drivers may be installed. Contact the vendor of your intended operating system to receive the latest drivers for the Intel ICH2 (82801BA) EIDE interface.

7

Watchdog Timer

This chapter explains the operation of the NuPRO-840's watchdog timer. It provides an overview of watchdog operation and features, as well as a sample code to help you learn how the watchdog timer works.

Watchdog Timer Overview

The primary function of the watchdog timer is to monitor the NuPRO-840's operation and take corrective action if the software fails to function as programmed. The major features of the watchdog timer are:

- Two-stage
- Enabled and disabled through software control
- Armed and strobed through software control

Watchdog Timer Architecture

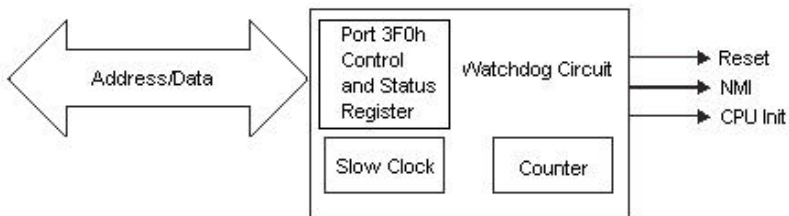

Figure 5: Watchdog Timer Architecture

The NuPRO-840's custom watchdog timer circuit is implemented in a programmable logic device. The watchdog timer contains a "Control and Status Register". The register allows the BIOS or user applications to determine if a watchdog time out was the source of a particular reset.

The watchdog timer drives the First and Second Stages as follows:

1. The watchdog times out (First Stage) after a selected timeout interval.
2. NMI or INIT (software selectable) is driven high.
3. A hard reset occurs (Second Stage).

The timeout period is 1 – 255 seconds or 1 – 255 minutes. The watchdog is normally strobed by reading the Watchdog Register (CRF5). This clears the counter. Writing to this register also clears the counter.

Using the Watchdog in an Application

The following topic is provided to help you learn how to use the watchdog in an application. The watchdog's Reset function is described. A sample code is provided. The Watchdog Reset is controlled through the watchdog's "Control and Status Register".

Watchdog Reset

An application using the reset feature enables the watchdog reset, sets the terminal count period, and then periodically strobes the watchdog to keep it from resetting the system. If a strobe is missed, the watchdog times out and resets the system hardware.

The example shown below will reset the system after 15 seconds.
begin:

```

;-----
; Enter the extend function mode, interrupt double-write
;-----
mov  dx,2eh
mov  al,87h
out  dx,al
out  dx,al

mov  dx,2eh
mov  al,2bh    ;CR2B, bit4-> 0 = WDTO
                ; bit4-> 1 = GP24
out  dx,al
mov  dx,2fh
mov  al,0c0h
out  dx,al
```

```

mov dx,2eh
mov al,07h
out dx,al
mov dx,2fh
mov al,08h ;device 8
out dx,al

mov dx,2eh
mov al,30h
out dx,al
mov dx,2fh
mov al,01h ;enable device 8
out dx,al

mov dx,2eh
mov al,07h
out dx,al
mov dx,2fh
mov al,08h ;device 8
out dx,al

mov dx,2eh
mov al,0f7h
out dx,al ;device 8,CRF7
mov dx,2fh
mov al,0c0h
out dx,al

mov dx,2eh
mov al,07h
out dx,al
mov dx,2fh
mov al,08h
out dx,al ;device 8

```

```

mov dx,2eh
mov al,0f5h ;device 8, CRF5
out dx,al
mov dx,2fh
mov al,00h ;bit3 -> 0 = second
;bit3 -> 1 = minute
out dx,al

```

```

mov dx,2eh
mov al,07h
out dx,al
mov dx,2fh
mov al,08h
out dx,al ;device 8

```

```

mov dx,2eh
mov al,0f6h ;device 8, CRF6
out dx,al
mov dx,2fh
mov al,0fh
out dx,al

```

```

;-----
; Exit extend function mode
;-----

```

```

mov dx,2eh
mov al,0aah
out dx,al

```

```

.exit
end

```

ADLINK also provides other examples and various sub functions for programmers to implement with their software. It is stored in the ADLINK CD.

Driver Installation

This chapter describes the installation procedures of all the device drivers associated with the NuPRO-840 for Windows 95/98/ME/NT4.0/2000/XP. For installation information of non-Windows based operating systems, please refer the extensive explanation inside the ADLINK CD

Intel 845D Chipset Hardware Configuration File Installation

This section describes system requirements of Intel 845D chipset Device Driver. This driver has been designed for and tested with Windows 95/98/ME/2000/XP.

The system must contain an Intel Pentium 4 processor and chipset configuration. Ensure that a mouse is connected to the system. One of the following versions of Windows 95/98/ME/2000/XP must be installed on the system prior to running the utility program.

- Windows* 95 4.00.950 (Original Release)
- Windows* 95 4.00.950a (OSR1)
- Windows* 95 4.00.950b (OSR2 without USB Supplement)
- Windows* 95 4.00.950b (OSR2.1 with USB Supplement)
- Windows* 95 4.00.950c (OSR2.5 with or without USB Supplement)
- Windows* 98 4.10.1998 (Original Release)
- Windows* 98 SE 4.10.2222 (Original Release)
- Windows* Me 4.90.3000 (Original Release)
- Windows* 2000 5.00.2195 (Original Release)
- Windows* XP 5.10.2526 (Release Candidate 2)

Installing Hardware Configuration Files

This subsection describes how to install the hardware configuration file on a system where Windows 95/98/ME/2000/XP is installed.

Note: Record the location of the Windows 95/98/ME/2000/XP directory before installing the driver.

1. Check the System Requirements. Windows 95/98/ME/2000/XP must be fully installed and running on the system prior to running this software.
2. Close any running applications.
3. The files are stored in an integrated application setup program. This program is designed for a Windows 95/98/ME/2000/XP program that allows the INF files to be installed.
4. Locate the directory X:\CHIPDRV\Chipset\I845D in the CD-ROM, and then Run "Setup.exe".
5. Click '**Next**' on the Welcome screen to read and agree to the license agreement. Click **Yes** if you agree to continue. NOTE: If you click **No**, the program will terminate.
6. Click '**Next**' on Readme Information screen to install INF files.
7. Click '**Finish**' to restart the system when prompted to do so.
8. Follow the screen instructions and use the default settings to complete the setup when Windows 95/98/ME/2000/XP re-starts. Upon re-start, Windows will display that it has found new hardware and is installing drivers for them. If **New Hardware Found** dialog box is displayed requesting the location of the drivers, use the mouse to click on the scrollbar and click on the <Windows directory>.
9. Select **Yes**, when prompted to re-start Windows 95/98/ME/2000/XP.

VGA Driver Installation

This section provides information on how to install the VGA driver that come in the Compact Disk with the package. Please follow the instructions set forth in this section carefully. Please note that there must be relevant software installed in your system before you could proceed to install the VGA driver.

Installing Drivers for Windows 98/ME/NT/2000

The following section describes the normal display driver installation procedures for Windows 98/ME/NT/2000. Use the following procedures when installing the display drivers for Windows 98/ME/NT/2000.

Installing the Drivers for Windows 98/ME

1. Boot Windows 98/ME.
2. The driver is included in the ADLINK CD. Run the **300win9x.exe** under the following directory: **X:\CHIPDRV\VGA\ISIS305**.
3. Click **Next>** on Welcome screen. And select *Typical* on Setup Type screen and click **Next>**.
4. Use default program folders on Select Program Folder screen. Click **Next>** to install driver. Finally, click **Finish** to re-start.

Installing the Drivers for Windows NT 4.0

The procedures below show you how to install the VGA driver for Windows NT 4.0.

1. Boot Windows NT 4.0.
2. The driver is included in the ADLINK CD. Locate the following directory: **X:\CHIPDRV\VGA\ISIS305\300nt40**.
3. Click **Start** on the tool bar and select **Settings** to click control panel.
4. Double-click **Display** icon. Select **Settings** tab and click **Display Type...** button. Click **Change...** button on Display Type screen. Then click **Have Disk...** to browse the 300nt40 folder in your hard disk. Open "Sis300.inf" under \300nt40\nt40.
5. Then open "Sheettab.ico" under \300nt40\Utility\Utilres\lco and "Bk.bmp" under \300nt40\Utility\Utilres\Bmp.
6. Click **OK** button to finish installation and re-start the system.

[IMPORTANT]: You should install the Windows NT 4.0 with at least Service Pack 4 (version number: 4.00.1381) first before installing the VGA driver. If you don't have the Windows NT 4.0 Service Pack 4, please contact your software vendor or download it from Microsoft's web site.

Installing the Drivers for Windows 2000/XP

1. Boot Windows 2000/XP.
2. The driver is included in the ADLINK CD. Run the **300win2kxp.exe** under the following directory:
X:\CHIPDRV\VGA\ISIS305.
3. Click **Next>** on Welcome screen. And select *Typical* on Setup Type screen and click **Next>**.
4. Use default program folders on Select Program Folder screen. Click **Next>** to install driver. Finally, click **Finish** to re-start.

NOTE: As the SIS305 does not support multi-display; the system may halt if other PCI VGA card drivers are used under windows 2000. After installing the SIS305's windows 2000 VGA driver, and you find that the system hangs during system boot-up, it is recommend that the SIS305 driver be removed first and then use other PCI VGA drivers to boot system and then change back to the SIS305 driver.

LAN Driver Installation

This section describes the LAN driver installation for the onboard Ethernet controllers, the **Intel 82540EM** and **Intel 82562EM**. The relative drivers are located in the following ADLINK CD directory: **X:\CHIPDRV\LAN**.

The Intel LAN drivers supports the following OS or platforms: Windows 98 SE, Windows ME, Windows NT 4.0, Windows 2000, Windows XP, Linux

All the above drivers are included in the ADLINK CD. In the following section, we will describe the LAN driver installation for Windows 98 SE/ME, Windows NT 4.0, and Windows 2000/XP. For LAN driver installation of other OS's, please refer to the readme file in the CD.

Driver Installation on Windows 2000/XP

Windows 2000 may automatically try to install a LAN driver within its directory. We recommend you to manually install the most updated LAN driver, which comes with the ADLINK CD to guarantee compatibility. After installing Windows 2000, please update to the new drivers by following these procedures.

1. Boot Windows 2000.
2. The driver is included in the ADLINK CD. Run the **Setup.exe** under the following directory: **X:\CHIPDRV\LAN82540EM\2K_XP**.
3. Click **Install now** button on Installation instructions screen to install drivers.
4. After installing, click **Finish** button to finish the installation.

Driver Installation on Windows 98/98SE/ME

Windows 98 will install the LAN drivers automatically. We recommend you to manually update the LAN drivers, which come with the ADLINK CD to guarantee compatibility. After installing Windows 98, please update to the new drivers by following these procedures.

1. Boot Windows 98.
2. The driver is included in the ADLINK CD. Run the **Setup.exe** under the following directory: **X:\CHIPDRV\LAN82540EM\98_Me**.
3. Click **Install now** button on Installation instructions screen to install drivers.
4. After installing, click **Restart now** button to restart the system.

Driver Installation on Windows NT

Windows NT may ask to install a LAN driver from its own library of drivers. We recommend you to manually update the LAN drivers, which come with the ADLINK CD to guarantee compatibility. After installing Windows NT, please update to the new driver by following these procedures.

1. Boot Windows NT.
2. The driver is included in the ADLINK CD. Run the **Setup.exe** under the following directory: **X:\CHIPDRV\LAN82540EMWT4.0**.
3. Click **Install now** button on Installation instructions screen to install drivers.
4. After installing, click **Restart now** button to restart the system.



Specifications

Electrical

This section outlines the electrical specifications of the NuPRO-840

General CompactPCI Features

- Fully compliant to PCI rev. 2.2 standards

Processor Socket

- mPGA478 ZIF socket

Processor

- Intel Pentium 4 FC-PGA2 CPU

Secondary Cache

- Built-in CPU

Bus Speed

- 400 MHz FSB

Chipset

- Intel 82845 DDR

Memory Sockets

- Two 184-pin DDR DIMM sockets
- Max. 2GB DDR SDRAM
- Memory type: 200MHz DDR SDRAM

Integrated Graphics Controller

- SIS 305 3D Graphics engine with 8/16MB Video Memory
- AGP 2X, ACPI and VESA compliant
- Up to 1600x1200 resolution

Audio (optional)

- Integrated i845 chipset with Line-in, Line-out & MIC Connectors with ADLINK DB-AC97S and Meets AC'97 standards

BIOS

- Award BIOS, support PnP
- Intel 82802AB Firmware Hub (512KB) for BIOS update
- DMI BIOS Support: Desktop Management Interface (DMI) allows users to download system hardware-level information such as CPU type, CPU speed, internal & external frequencies and memory size.
- Supports system soft-off (via ATX power supply)
- Supports Intel Preboot Execution Environment (PXE)

PCI Bus Ethernet Interface

- Intel 82845 built-in 82559 compatible high performance IEEE802.3 10/100-BaseTx Ethernet controller
- On-board Intel 82559 high performance IEEE 802.3 10/100BaseTx Ethernet controller for secondary Ethernet port
- Supports IEEE 802.3u auto-negotiation for 10/100BaseTx
- Supports IEEE 802.3x 100Base-Tx flow control
- Reserved with pin header for Ethernet's LED for user's applications
- IEEE802.3u auto-negotiation support for automatic speed selection
- IEEE 802.3X (100base-TX Flow control support)

Enhanced IDE

- Bus Master IDE controller, two EIDE interfaces for up to four IDE devices, support PIO Mode 3/4 or Ultra DMA/33/66/100 IDE devices

Super I/O Chipset

- Winbond W83627HF

Parallel Port

- One high-speed parallel port, SPP/EPP/ECP mode
- ESD protection to 4KV
- Downstream device protection to 30V

Serial Port

- Two 16550 UART compatible ports with RS-232 interface
- ESD protection to 2KV

FDD Interface

- One floppy interface, supporting 2 floppy drives

USB Interface

- Two USB pin-header connectors, compliant with USB Specification Rev. 1.1, Individual over-current protection

Watchdog Timer

- Programmable I/O port 2Eh and 2Fh to configure watchdog timer
- Time-out timing select 1~255 seconds or 1~255 minutes

Keyboard and Mouse Connectors

- One 6-pin circular DIN connector on the rear panel
- Power provided to keyboard/mouse is protected by a 1.1A polyswitch

HISA

- ISA bus high driving capability up to 64mA on all data address and control lines

Environment

Operating ambient temperature: 0 to 60°C

Storage temperature: -40 to 85°C

Relative Humidity: 5% to 95% non-condensed

Shock:

- Operating: 3G peak-to-peak, 10ms duration, 10 pulses in each of 3 axes.
- Non-operating: 30G peak to peak, 10ms duration, 10 pulses in each of 3 axes.

Vibration:

- Operating: 0.5Grms, 10 to 1000 Hz, random.
- Non-operating: 6Grms, 10 to 1000 Hz, random

Altitude:

- Operating: -500 to 5,000 m. (-1,640 to 16,404 ft.)
- Non-operating: -500 to 15,000 m. (-1,640 to 49,213 ft.)

Mechanical

This section describes the board dimensions of the NuPRO-840

Board Dimensions

The NuPRO-840 is fully compliant to PCI rev. 2.2 standards for all mechanical parameters. Mechanical dimensions are shown below.

- Board Length: 338 mm
- Board Width: 122 mm

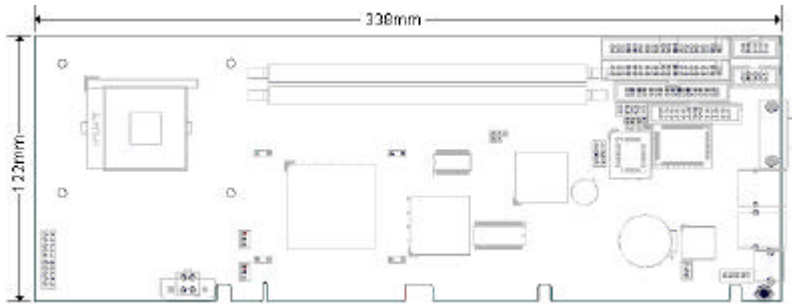

Figure 6: Board Dimensions

B

Jumpers & Connectors

A detailed description and pin-out for each connector is given in the following section. The jumpers on the NuPRO-840 allow you to configure your main board according to the needs of your applications. If you have doubts about the best jumper configuration for your needs, contact your dealer or sale representatives

The proceeding section identifies where each jumper and connector is located on the main board.

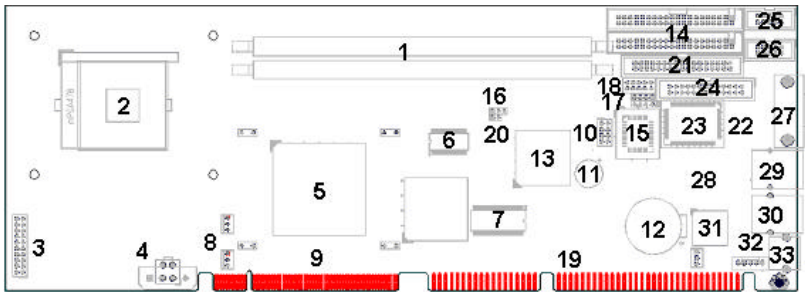
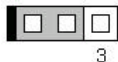

Figure 7: Location items on the NuPRO-840

Position	Description	Reference
1	DDR SDRAM Memory Socket	DIMM1, DIMM2
2	CPU socket mPGA478	U2
3	Front Panel Pin Header	CN16
4	Power Controller	CN19 (CN20)
5	Memory Control Hub	U14
6	Clock Generator	U6
7	Display Cache	U18, U31
8	Fan Connector	FN1, FN2, FN3
9	PCI Golden Finger	
10	USB1.1 Pin Header	CN11
11	Buzzer	BZ1
12	Battery and Socket	BT1
13	I/O Controller Hub	U8
14	IDE1 and IDE2	CN1, CN3
15	Firmware Hub (BIOS)	U5
16	Clear CMOS Jumper	JP1
17	SMBus Pin Header IrDA Pin Header	CN8 CN10
18	AC'97 Pin Header	CN6
19	ISA Golden Finger	
20	Case Open Pin Header	JP2
21	Floppy Disk Connector	CN5
22	External Temperature Pin Header	CN12
23	Super I/O	U4
24	PRINTER Port	CN7
25	COM1 Port	CN4
26	COM2 Port	CN2
27	VGA Connector	CN9
28	LAN1 IC (82562)	U10
29	LAN1 Connector (RJ-45)	CN13
30	LAN2 Connector (RJ-45)	CN22
31	LAN2 IC (82540)	U39
32	External KB/MS Connector	CN18
33	KB/MS Connector	CN17

Table 7: Cross-reference table for figure 6.

Clear CMOS Jumper – JP1



JP1	Function
1-2	Normal
2-3	Clean CMOS

Table 8: Clear CMOS Jumper

VGA Connector – CN9

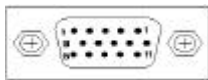

Pin	Signal	Pin	Signal
1	RED	9	V_PWR
2	GREEN	10	GND
3	BLUE	11	+5V
4	+5V	12	I ² C_DATA
5	GND	13	V_HSYNC
6	GND	14	V_VSYNC
7	GND	15	I ² C_CLK
8	GND		

Table 9: VGA Connector Pin Assignment

Keyboard/Mouse Connector – CN17

Please use ADLINK's Y-Cable when using Keyboard and Mouse at the same time. The cable follows the PC'99 standard, purple for Keyboard and Green for Mouse. You can connect either keyboard or mouse if the Y cable is not used.

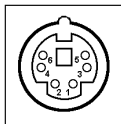

Pin	Signal
1	KBDAT
2	MSDAT
3	KYMSE_GND
4	KB5V
5	KBCLK
6	MSCLK

Table 10: Pinout of PS/2 connector

LAN1 RJ-45 Connector – CN13

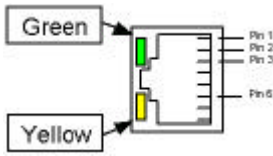

Pin	Signal	Pin	Signal
1	LAN1_TDP	5	NC
2	LAN1_TDN	6	LAN1_RDN
3	LAN1_RDP	7	NC
4	NC	8	GND

Table 11: Pinout of LAN1 RJ-45

LAN1 LED status

LED Color	Status	Function
Green (Speed status)	ON	100Mbps
	OFF	10Mbps
Yellow (Link status)	ON	Link
	OFF	Link off
	Blinking	Data transfer in progress

Table 12: LAN LED status

10/100/1000 LAN2 RJ45 Connector – CN22

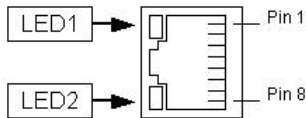

Pin	Signal
1	LAN2_TDP0
2	LAN2_TDN0
3	LAN2_RDP0
4	LAN2_TDP1
5	LAN2_TDN1
6	LAN2_RDN0
7	LAN2_RDP1
8	LAN2_RDP1

Table 13: Pin Definition of Gigabit LAN2 RJ-45

LAN2 LED status

LED	Status & Color	Function
LED1	ON (Green)	Link
	OFF	Link off
	Blinking (Green)	Data transfer in progress
LED2	OFF	10Mbps
	ON (Green)	100Mbps
	ON (Yellow)	1000Mbps

Table 14: LAN2 LED status

SMBus Connector – CN8

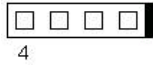

Pin	Signal	Function
1	+5V	Power
2	SMBCLK	Clock
3	SMBDATA	Data
4	GND	Ground

Table 15: Pin Assignment of SMBus Connector

AC'97 Connector – CN6

This connector is an optional function, which can be connected to the DB-AC97s board for AC'97 audio in/out. DB-AC97S support Line-in, Line-Out, CDROM-in connector. Please contact with ADLINK's reseller for this board.

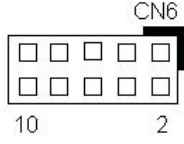

Pin	Signal	Function
1	GND	Ground
2	AC_BITCLK	Bit Clock
3	GND	Ground
4	AC_SDIN0	Data Input 0
5	+5V	Power
6	AC_SDOUT	Data Output
7	+5V	Power
8	AC_SDIN1	Data Input 1
9	AC_SYNC	Syncho-signal
10	AC_RSTJ	Reset

Table 16: Pinout of AC'97 Connector

Dual USB Connector – CN11

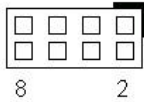

Pin	Pin	Signal Name
1	2	VCC
3	4	USB0- / USB1-
5	6	USB0+ / USB1+
7	8	Ground

Table 17: Pin Assignment of the USB Connector

COM1 and COM2 Pin Header – CN4 & CN2

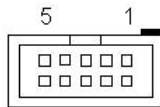

Pin	Signal Definition
1	DCD, Data carrier detect
2	RXD, Receive data
3	TXD, Transmit data
4	DTR, Data terminal ready
5	GND, ground
6	DSR, Data set ready
7	RTS, Request to send
8	CTS, Clear to send
9	RI, Ring indicator
10	NC

Table 18: COM Connector Pin Assignment

Parallel Port Connector – CN7

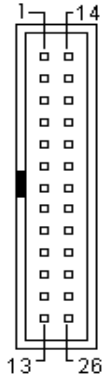

Pin	Signal	Function
1	PP_STB_L	Strobe
2	PP_PD0	Data 0
3	PP_PD1	Data 1
4	PP_PD2	Data 2
5	PP_PD3	Data 3
6	PP_PD4	Data 4
7	PP_PD5	Data 5
8	PP_PD6	Data 6
9	PP_PD7	Data 7
10	PP_ACK_L	Acknowledge
11	PP_BUSY	Busy
12	PP_PE	Paper Error
13	PP_SLCT	Select
14	PP_AFD_L	Auto Feed
15	PP_ERR_L	Error
16	PP_INIT_L	Initialize
17	PP_SLIN_L	Select In
18	GND	Ground
19	GND	Ground
20	GND	Ground
21	GND	Ground
22	GND	Ground
23	GND	Ground
24	GND	Ground
25	GND	Ground

Table 19: Pin Assignment of Parallel Port Connector

Floppy Connector – CN5

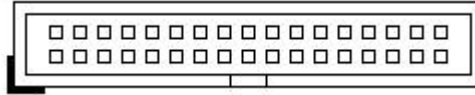

Pin	Signal	Function	Pin	Signal	Function
1	GND	Ground	2	FLPREDWC_L	Extended Density
3	GND	Ground	4	NC	No Connect
5	KEY	-	6	FLPDRATE0	Data Rate
7	GND	Ground	8	FLPINDEXT_L	Index
9	GND	Ground	10	FLPMOTEAL_L	Motor A Select
11	GND	Ground	12	FLPDRVSB_L	Drive B Select
13	GND	Ground	14	FLPDRVSA_L	Drive A Select
15	GND	Ground	16	FLPMOTEBL_L	Motor B Select
17	GND	Ground	18	FLPDIR_L	Step Direction
19	GND	Ground	20	FLPSTEP_L	Step Pulse
21	GND	Ground	22	FLPWDATA_L	Write Data
23	GND	Ground	24	FLPWGATE_L	Write Gate
25	GND	Ground	26	FLPTRK0_L	Track 0
27	GND	Ground	28	FLPWPT_L	Write Protect
29	GND	Ground	30	FLPRDATA_L	Read Data
31	GND	Ground	32	FLPSIDE1_L	Side 1
33	GND	Ground	34	FLPDSKCHG_L	Disk Change

Table 20: Pin Assignment of FDD Connector

Primary IDE Connector– CN1

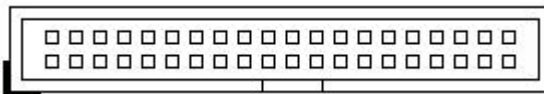

Pin	Signal	Function	Pin	Signal	Function
1	PIDRSTJ	Reset	2	GND	Ground
3	PDD7	Data 7	4	PDD8	Data 8
5	PDD6	Data 6	6	PDD9	Data 9
7	PDD5	Data 5	8	PDD10	Data 10
9	PDD4	Data 4	10	PDD11	Data 11
11	PDD3	Data 3	12	PDD12	Data 12
13	PDD2	Data 2	14	PDD13	Data 13
15	PDD1	Data 1	16	PDD14	Data 14
17	PDD0	Data 0	18	PDD15	Data 15
19	GND	Ground	20	KEY	-
21	PDRQ	Request	22	GND	Ground
23	PDIOWJ	I/O Write	24	GND	Ground
25	PDIORJ	I/O Read	26	GND	Ground
27	PDIORDY	I/O Ready	28	GND	Ground
29	PDDACKJ	DMA Acknowledge	30	GND	Ground
31	PIDEIRQ	Interrupt Request	32	NC	No Connect
33	PDA1	Device Address 1	34	P66DECT	ATA66/100 Detection
35	PDA0	Device Address 0	36	PDA2	Device Address 2
37	PDCSJ1	Chip Select 1	38	PDCSJ3	Chip Select 3
39	IDEACTPJ	Device Active	40	GND	Ground

Table 21: Pin Assignment of Primary IDE Connector

Secondary IDE Connector– CN3

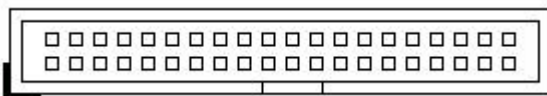

Pin	Signal	Function	Pin	Signal	Function
1	SIDERSTJ	Reset	2	GND	Ground
3	SDD7	Data 7	4	SDD8	Data 8
5	SDD6	Data 6	6	SDD9	Data 9
7	SDD5	Data 5	8	SDD10	Data 10
9	SDD4	Data 4	10	SDD11	Data 11
11	SDD3	Data 3	12	SDD12	Data 12
13	SDD2	Data 2	14	SDD13	Data 13
15	SDD1	Data 1	16	SDD14	Data 14
17	SDD0	Data 0	18	SDD15	Data 15
19	GND	Ground	20	KEY	-
21	SDREQ	Request	22	GND	Ground
23	SDIOWJ	I/O Write	24	GND	Ground
25	SDIORJ	I/O Read	26	GND	Ground
27	SIORDY	I/O Ready	28	GND	Ground
29	SDDACKJ	DMA Acknowledge	30	GND	Ground
31	SIDEIRQ	Interrupt Request	32	NC	No Connect
33	SDA1	Device Address 1	34	S66DECT	ATA66/100 Detection
35	SDA0	Device Address 0	36	SDA2	Device Address 2
37	SDCSJ1	Chip Select 1	38	SDCS3	Chip Select 3
39	IDEACTSJ	Device Active	40	GND	Ground

Table 22: :Pin Assignment of Secondary IDE Connector

FAN Connector – FN1, FN2, FN3



Pin	Signal	Function
1	GND	Ground
2	FAN_12V	Fan +12V
3	FANSPD_1	Fan Tachometer Output

Table 23: Pinout of the Fan Connector

IrDA Connector – CN10

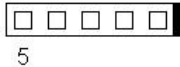

Pin	Signal	Function
1	+5V	Power
2	NC	No Connect
3	IRRXD	Infrared Receive Data
4	GND	Ground
5	IRTXD	Infrared Transmit Data

Table 24: Pinout of the Fan Connector

Thermal Connector – CN12

The connector is connected to a thermal sensor that is used to detect the systems temperature for monitoring application program's.



Pin	Signal	Function
1	TGND	Thermal Ground
2	VTIN	Thermal Voltage Input

Table 25: Pinout of the Thermal Connector

Front-Panel Header – CN16

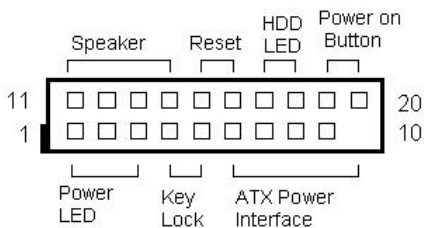

Pin	Signal	Function	Pin Groups
1	+5V	Power	Power LED
2	NC		
3	PLED	Power LED signal	
4	KEYLOCK	Keyboard lock	Key Lock
5	GND	Ground	
6	GND	Ground	ATX Power Interface
7	NC		
8	PWRON	Power-on signal	
9	+5VSB	Standby Power	
10	NC		Chassis Speaker
11	WDSPK	Speaker signal	
12	NC		
13	NC		
14	+5V	Power	RESET Button
15	RESETBT	RESET Button signal	
16	GND	Ground	Hard Disk LED
17	HDDLED	Hard Disk LED signal	
18	+5V	Power	
19	PWRBT	POWER Button signal	Power on Button
20	GND	Ground	

Table 26: Pinout of the Front Panel Header

External Keyboard Connector – CN18



Pin	Signal	Function	Comments
1	VCC (+5V)	Power	Keyboard Interface
2	GND	Ground	
3	NC	NC	
4	KBD Data	Data Signal	
5	KBD Clock	Clock Signal	

Table 27: Pinout of the External Keyboard Connector

CASE Open Connector – JP2

The signal is connected to the limit switch sensor of the chassis to detect the case open or closed.



Pin	Signal	Function
1	CASEOPEN	Case Open Signal
2	GND	Ground

Table 28: Pinout of the Fan Connector

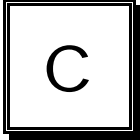

NuPRO-840 Comparison Table

Model	NuPRO-840DV	NuPRO-840LV
Processor	Pentium 4	Pentium 4
Chipset	Intel 82845 DDR	Intel 82845 DDR
BIOS	Phoenix-Award	Phoenix-Award
Max. System Memory	2GB un-buffered	2GB un-buffered
Memory Sockets	2 x DDR DIMM	2 x DDR DIMM
VGA	SIS305 VGA chip	SIS305 VGA chip
Ethernet	Dual LAN 82540 Gigabit LAN	Single LAN
Multi I/O Chip	Winbond 83627HF	Winbond 83627HF
Enhanced IDE (ATA-100)	Yes	Yes
2S/1P	Yes	Yes
USB	Yes	Yes
IrDA	Yes	Yes
Audio	Yes	Yes
H/W Monitoring	Winbond 83627HF	

Table 29: NuPRO-840 Comparison table

Warranty Policy

Thank you for choosing ADLINK. To understand your rights and enjoy all the after-sales services we offer, please read the following carefully.

1. Before using ADLINK's products, please read the user 's manual and follow the instructions carefully. When sending in damaged products for repair, please attach an RMA application form.
2. All ADLINK products come with a two-year guarantee, free of repair charges.
 - The warranty period starts from the product's shipment date from ADLINK's factory
 - Peripherals and third-party products not manufactured by ADLINK will be covered by the original manufacturers' warranty
 - End users requiring maintenance services should contact their local dealers. Local warranty conditions will depend on the local dealers
3. Our repair service does not cover two-year guarantee while damages are caused by the following:
 - a. Damage caused by not following instructions on users manual.
 - b. Damage caused by carelessness on the users' part during product transportation.
 - c. Damage caused by fire, earthquakes, floods, lightening, pollution and incorrect usage of voltage transformers.
 - d. Damage caused by unsuitable storage environments with high temperatures, high humidity or volatile chemicals.
 - e. Damage caused by leakage of battery fluid when changing batteries.
 - f. Damages from improper repair by unauthorized technicians.
 - g. Products with altered and damaged serial numbers voids the guarantee
 - h. Other categories not protected under our guarantees.
4. Customers are responsible for the fees regarding transportation of damaged products to our company or to the sales office.

5. To ensure the speed and quality of product repairs, please download an RMA application form from our company website www.adlinktech.com. Damaged products with RMA forms attached receive priority.

For further questions, please contact our FAE staff.

ADLINK: service@adlinktech.com

Test & Measurement Product Segment: NuDAQ@adlinktech.com

Automation Product Segment: Automation@adlinktech.com

Computer & Communication Product Segment: NuPRO@adlinktech.com;
NuIPC@adlinktech.com