

GOT-2570S

**5.7" STN LCD, Xscale-based touch screen
computer**

User's Manual

Disclaimers

The information in this manual has been carefully checked and is believed to be accurate. AXIOMTEK Co., Ltd. assumes no responsibility for any infringements of patents or other rights of third parties which may result from its use.

AXIOMTEK assumes no responsibility for any inaccuracies that may be contained in this document. AXIOMTEK makes no commitment to update or to keep current the information contained in this manual.

AXIOMTEK reserves the right to make improvements to this document and/or product at any time and without notice.

No part of this document may be reproduced, stored in a retrieval system, or transmitted, in any form or by any means, electronic, mechanical, photocopying, recording, or otherwise, without the prior written permission of AXIOMTEK Co., Ltd.

©Copyright 2003 by AXIOMTEK Co., Ltd.

All rights reserved.

June. 2004,

Printed in Taiwan

Edition V1.10

ESD Precautions

Integrated circuits on computer boards are sensitive to static electricity. To avoid damaging chips from electrostatic discharge, observe the following precautions:

- Do not remove boards or integrated circuits from their anti-static packaging until you are ready to install them.
- Before handling a board or integrated circuit, touch an unpainted portion of the system unit chassis for a few seconds. This helps to discharge any static electricity on your body.
- Wear a wrist-grounding strap, available from most electronic component stores, when handling boards and components.

Trademarks Acknowledgments

AXIOMTEK is a trademark of AXIOMTEK Co., Ltd.

IBM is a registered trademark of International Business Machines Corporation.

MS-DOS, Microsoft C and QuickBasic are trademarks of Microsoft Corporation.

TURBO C is a trademark of Borland Inc.

BASIC is a trademark of Dartmouth College.

Intel is a trademark of Intel Corporation.

Other brand names and trademarks are the properties and registered brands of their respective owners.

Unpacking

The GOT-2570S is packed in an anti-static bag. The product has components that are easily damaged by static electricity. Do not remove the anti-static wrapping until proper precautions have been taken. Safety instructions in front of this User's Manual describe anti-static precautions and procedures.

After unpacking the product, place it on a raised surface and carefully inspect the board for any damage that might have occurred during shipment. Ground the product and exercise extreme care to prevent damage to the product from static electricity.

Integrated circuits will sometimes come out of their sockets during shipment.

The GOT-2570S 5.7" STN LCD, Xscale-based touch screen computer package includes the following:

- GOT-2570S * 1
- Driver CD *1
- USB sync. cable *1
- Touch pen * 1
- Fuse * 1
- Panel mount * 2

Make sure that all of the items listed above are present.

What To Do If There Is A Problem

If there are damaged or missing parts, contact your supplier and/or dealer immediately. Do not attempt to apply power to the product if there is damage to any of its components.

Safety Instructions

Overview

This section states the safety instructions, which must be followed when installing, operating and servicing the GOT-2570S. If neglected, physical injury and death may follow, or damage may occur to controller and related equipment. The material in this chapter must be studied before attempting any work on, or with, the unit.

Warnings and Notes

This manual distinguishes safety instructions. Warnings are used to inform of conditions, which can, if proper steps are not taken, lead to a serious fault condition, physical injury or death. Notes are used when the reader is required to pay special attention or when there is additional information available on the subject. Notes are less crucial than warnings, but should not be disregarded.



Warnings

Readers are informed of situations that can result in serious physical injury and/or serious damage to equipment with the symbol shown to the left. A Warning symbol indicates that the reader should pay special attention to the accompanying text. Precautionary steps should be taken to insure that the installation is in compliance with warnings. Warnings include hazardous conditions that could cause personal injury or equipment damage if care is not taken. The text next to this symbol describes ways to avoid the danger.

Warnings

Dangerous Voltage Warnings: Warns of situations in which high voltage can cause physical injury and or

damage equipment.

General warning: Warns of situations, which can cause physical injury and or damage equipment by means other than electrical.

Electrostatic Discharge Warning: Warns of situations in which an electrostatic discharge can damage equipment.

Readers are notified of the need for special attention or additional information available on the subject with the following symbols:

CAUTION! Aims to draw special attention to it.

Note: **Note:** gives additional information or points out more information available on the subject.

Table of Contents

DISCLAIMERS	II
ESD PRECAUTIONS	III
UNPACKING	IV
SAFETY INSTRUCTIONS	V
CHAPTER 1 INTRODUCTION	1
1.1 General Description	1
1.2 Features	2
1.3 Specifications	2
CHAPTER 2 INSTALLATION INSTRUCTIONS	5
2.1 Mounting Instructions	5
2.1.1 Location Considerations	5
2.1.2 Making a NEMA-4 Mounting	5
2.1.3 Environmental Considerations	7
2.2 Power Connections	8
2.2.1 Power Requirements	9
2.2.2 Grounding Requirements	11
2.2.3 CE Requirements	12
2.2.4 Safety Guidelines	12
2.3 Communications Connections	14
2.3.1 COM 1 [RS-232]	14
2.3.2 COM2 [RS-232] & COM3 [RS-422/485]	16
2.3.3 Dip Switch	17

2.4	CE Requirements	18
2.5	Dimensions of GOT-2570S	19
CHAPTER 3 WINDOWS CE.NET -----		21
3.1	Introduction	21
3.2	Utilities.....	22
3.2.1	Soft-Keyboard	22
3.2.2	System Settings	23
3.2.3	IPSM	26
3.2.4	Startup.....	27
3.2.5	Remote Desktop Connection (Windows XP only)	28
3.3	GOT-2570S Networking	31
3.3.1	Networking via Ethernet.....	31
3.3.2	Networking via USB Client Port	32
3.3.3	Web browser.....	34
3.4	Application program development	35
3.4.1	Microsoft eMbedded Visual C++ 4.0	35
3.4.2	GOT-2570S SDK.....	37
APPENDIX A EXAMPLE -----		39
APPENDIX B HOW TO UPDATE WINDOWSCE IMAGE-----		41
APPENDIX C HOW TO USE DEVELOPMENT TOOLS-EMBEDDED C++4.0---		43

Chapter 1

Introduction

1.1 General Description



The GOT-2570S series are fan-less and compact-size touch panel computers. It equips with 5.7" STN LCD display, Windows CE.NET and low power consumption CPU, Intel Xscale PXA255. Therefore, GOT-2570S series are good cost-effective choices for operator interface applications.

The GOT-2570S adopts most reliable and stable design. With fan-less CPU and CompactFlash card, GOT-2570S is especially suitable for vibration environment such as transportation, semiconductor etc. In addition, GOT-2570S is also bundled with Windows CE.NET, which forms a bridge that lets GOT-2570S be an open HMI solution for system integration. For connecting other devices, the GOT-2570S also provides several interfaces: RS-232/422/485, Ethernet etc.

1.2 Features

- Fan-less and low power consumption CPU- Xscale PXA255
- 5.7" QVGA color STN LCD
- Windows CE.NET supported and flash ROM on-board
- Slim and compact size design
- Suitable for reliable and vibration application – Fan less and CompactFlash card
- NEMA 4 / IP65 compliant front panel
- Support Compact Framework
- Over-voltage power protection – fuse

1.3 Specifications

- Construction: plastic molding housing
- Display: 5.7" QVGA Color STN LCD
- CPU and core logic: Intel™ Xscale PXA255
- Flash ROM/SDRAM on board
32 MB Flash ROM / 64MB SDRAM
- 1 CompactFlash™ card slot
- I/O: 2 serial ports
COM1: RS-232, COM2: RS-232/422/485
- 1 Ethernet port (10Base-T)
- 2 USB host ports
- 1 USB client for ActiveSync
- Sound output: 16 bit sound output
- RTC: Dallas DS1685
- Power input: 24 VDC, 0.5A maximum
- Dimension (W x H x D): 204 x 150 x 48mm
- Weight: 1.0kg

LCD Display

- Display type: STN color LCD
- Display size (diagonal): 5.7"
- Max colors: 4096
- Resolution: 320 x 240
- Pixel pitch (HxV, mm): 0.36 x 0.36
- Viewing angle: 100°
- Luminance (cd/m²): 150
- Storage temperature: -20~60°C
- Operating temperature: 0~45°C
- Backlight: CCFL
- Contrast ratio 30:1

Touch screen

- Type: 4-wire, analog resistive
- Resolution: 320*240
- Light transmission: above 80%
- Life: 1 million activation minimal

Fuse

- BUSSMANN
- Fast Acting, Glass Tube
- Rating: 250VAC, 1A
- Size: 5x20mm

Environmental Specifications

- Operating temperature: 0° ~ 45°C (32° ~ 113°F)
- Relative humidity: 10% ~ 90% @ 40°C, non-condensing
- Shock (operation): 10 to 25Hz(X,Y,Z direction 2G
30minutes)
- EMI: Complies FCC class A

GOT-2570S User's Manual

- CE: Complies with EN50081-2 and EN50082-2 standards
- Front panel meets NEMA4 / IP65

Chapter 2

Installation Instructions

2.1 Mounting Instructions

2.1.1 Location Considerations

Care should be taken when locating equipment behind the unit to ensure that AC power wiring, PLC output modules, contactors, starters and relays, and any other source of electrical interference are located away from the back of the unit.

Particular note should be taken to the position of variable speed drives and switching power supplies. Their input and load cables should be screened to a central star earth point.

2.1.2 Making a NEMA-4 Mounting

Panel Details The unit can be mounted into panels with a depth of 4"(105mm). It is recommended that the unit be mounted on the front panel of a steel enclosure, through an appropriate opening*. Allow a clearance of 1"(25mm) around the sides of the unit for mounting hardware. Allow clearance for cable connections to the back of the unit. Unit depth may vary according to cable type used. Typically, plan a depth to accommodate at least 4"(105mm) behind the panel.

NEMA-4 Mounting Put the unit through the panel cut out. Slide the clamps into the 6 holes provided around the case. Tighten the clamping screws in an even pattern until

the unit is secured in the panel.

Caution! Do not over tighten mounting clamps!

Note: Specifications Note:

To seal to NEMA-4 specifications, all supplied mounting clamps must be used and panel cannot flex more than 0.010".

2.1.3 Environmental Considerations

- The GOT-2570S are to be used indoors as built in displays. Make sure that the displays are installed correctly and that the operating limits are followed (See Specifications).
- Do not operate the unit in areas subject to explosion hazards due to flammable gases, vapors or dusts.
- The unit should not be installed where fast temperature variations and/or high humidity are present. This will cause condensation of water in the device.
- Do not install these terminals in environments where have inflammable gases.

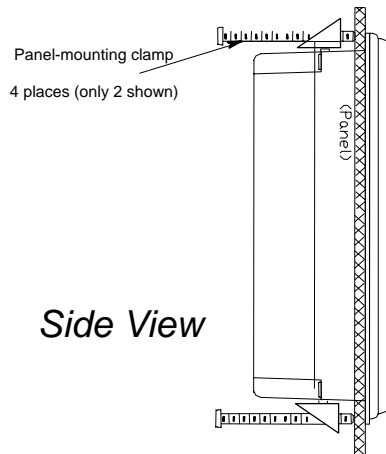

2.2 Power Connections

Make sure that all local and national electrical standards are met when the installing the unit. Contact your local authorities to determine which codes apply.



2.2.1 Power Requirements

Power	The GOT-2570S can be powered by DC power only. The specified voltage range is +21 to 25 Volts DC. This insures compatibility with most controller DC systems. The power conditioning circuitry inside the unit is accomplished by a switching power supply. The peak starting current can be as high as 700mA.
Fusing Requirements	If the display does not come on within 2 seconds of power up, remove power. An internal fuse will prevent damage if the polarity of the DC power is incorrect. Check wiring to insure proper connections and try to power up again.
Caution High Voltage	An Internal fuse will prevent damage for over voltage condition however it isn't guaranteed. DC voltage sources should provide proper isolation from main AC power and similar hazards.
Caution Emergency Stop	A Hard-wired EMERGENCY STOP should be fitted in any system using a GOT-2570S to comply with ICS Safety Recommendations.
Caution Supply Voltage Condition	Do not power the GOT-2570S and inductive DC loads, or input circuitry to the controller, with the same power supply. Note: The 24 VDC output from some controllers may not have enough current to power the GOT-2570S.
Caution Wire Routing	Wire lengths should be minimized (Maximum 1600' (500 m) shielded, 1000' (300 m) unshielded). Wires should be run in pairs with a neutral or

common paired with a hot or signal line.

If wiring is to be exposed to lightning or surges, use appropriate surge suppression devices.

Keep AC, high energy, and rapidly switching DC wiring separate from signal wires.

Equip ungrounded DC supplies with a resistor and capacitor in parallel to earth ground. This provides a path for static and high frequency dissipation. Typical values to use are 1M Ω and 4700pF.

Connection

To make a connection, strip about 3/8" of insulation off the end of the wire, turn the connector screw counterclockwise until the gap is wide open, insert the wire all the way in, and turn the screw clockwise until it's tight.

Connect positive DC line to the '+24V' terminal and the DC ground to the '0V' terminal.

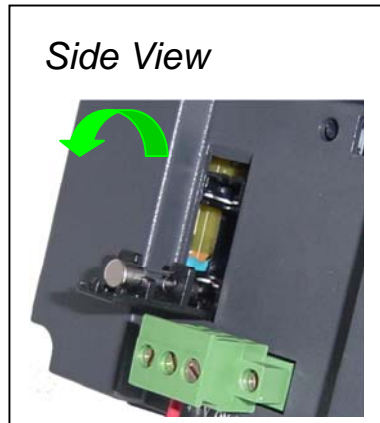

FUSE Replacement:

The fuse use on GOT-2570S is:

BUSSMANN

Fast Acting, Glass Tube

Rating: 250VAC, 1A

Size: 5x20mm

Warning:



1. Make sure the power off before replace the fuse.
2. Do not replace the fuse with a different rating fuse.

2.2.2 Grounding Requirements

Chassis ground must be used. DC ground is not directly coupled to Earth ground internally. It is preferable not to ground DC negative return to chassis ground as poor site earths can introduce noise into a system, but if necessary an earth connection should be made, from the power supply return point to the central star earth point. Ground conductors should be as short and as large in size as possible. The conductors must always be large enough to carry the maximum short circuit current of the path being considered. Ground conductors should be connected to a tree from a central star earth ground point. This ensures that no ground conductor carries current from any other branch.

2.2.3 CE Requirements

To make a GOT-2570S comply with EMC directives, and to reduce susceptibility to electrical interference, a separate #14 AWG ground wire should be taken to the chassis ground terminal of the power connector. This ground connection should be run directly to the central star earth connection point (as recommended in most Installation Instructions).

2.2.4 Safety Guidelines

This section presents recommended installation practices, and procedures. Since no two applications are identical, these recommendations should be considered as guidelines.

Hardware Considerations WARNING!

The system designer should be aware that devices in Controller systems could fail and thereby create an unsafe condition. Furthermore, electrical interference in an operator interface, such as a GOT-2570S, can lead to equipment start-up, which could result in property damage and/or physical injury to the equipment operator.

If you, or your company, use any programmable control systems that require an operator or attendant, you should be aware that this potential safety hazard exists and take appropriate precautions.

Although the specific design steps depend on your particular application, the following precautions generally apply to installation of solid-state programmable control devices. In addition, these precautions conform to the guidelines for installation of Controllers as recommended in the NEMA ICS 3-304 Control Standards.

Programming Considerations

To conform to ICS Safety Recommendations, checks should be placed in the controller to ensure that all writable registers that control critical parts of plant or machinery have limit checks built into the program, with an out-of-limit safe shut down procedure to ensure safety of personnel.

ICS 3-304.81 Safety Recommendations:

Consideration should be given to the use of an emergency stop function, which is independent of the programmable controller.

Where the operator is exposed to the machinery, such as in loading or unloading a machine tool, or where the machine cycles automatically, consideration should be given to the use of an electromechanical override or other redundant means, independent of the programmable controller, for starting and interrupting the cycle.

If provision is required for changing programs while the equipment is in operation, consideration should be given to the use of locks or other means of assuring that only authorized personnel can make such changes.

These recommendations are intended as safeguards against the failure of critical components and the effects of such failures or the inadvertent errors that might be introduced if programs are changed while the equipment is in operation. *

- The ICS 3-304.81 Safety Recommendations are reproduced by permission of the National Electrical Manufacturers Association from NEMA ICS 3-304

2.3 Communications Connections

There are several ports in the back of the case. Please take the following information for reference.

2.3.1 COM 1 [RS-232]

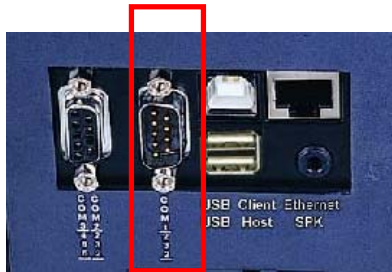

Cable Requirements
Caution

Different cables are required for various devices.

Restrict cable length to less than 50' (15m) for RS-232 devices to avoid communications problems.

Shielded cable must be used for long lengths or cables run in an electrically noisy environment.

Do not run cables next to AC power lines or near sources of electrical noise.

Be sure that the cable ends have been inserted all of the way into mating connectors and are secure

Pin Designations

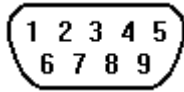

Pin assignment of the 9 Pin, Female, SUB-D, COM1 [RS-232] Port.

Note: This port is not used for downloading or for printing functions.

COM1 [RS-232]

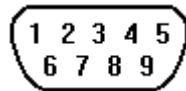

Pin#	Symbol	Function
1	DCD	Data Carrier Detect
2	RxD	Received Data
3	TxD	Transmitted Data
4	DTR	Data Terminal Ready
5	GND	Signal Ground
6	DSR	Data Set Ready
7	RTS	Ready to send output
8	CTS	Clear to send input
9	RI	Ring Indicator

2.3.2 COM2 [RS-232] & COM3 [RS-422/485]

The 9 Pin, male, SUB-D, COM2 [RS-232] & COM3 [RS-422/485] Port on the back of the unit is the downloading port (PC Connector) and RS-485/422 communications port for connecting to a device.



Connector COM2 [RS-232] & COM3 [RS-2422/485]

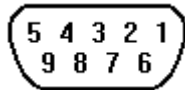

Pin Designations

Pin#	Symbol	COM2 (RS-232)	COM3 (RS-422)	COM3 (RS-485)
1	GND	GND	GND	GND
2	Tx+		RS-422 Transmit	
3	Tx-		RS-422 Transmit	
4	Rx+		RS-422 Receive	Data+
5	Rx-		RS-422 Receive	Data-
6	GND			
7	RxD	Receive		
8	TxD	Transmit		
9	Not used			

2.3.3 Dip Switch

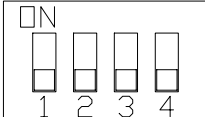
	Pin1	Pin2	Mode
	OFF	OFF	Normal
	ON	OFF	Touch Screen Calibrate mode
	OFF	ON	Boot Loader mode

Pin3, 4 unused

- **Touch Screen Calibrate mode:** In this mode when you power on the GOT-2570S, the screen will display a “+” sign at the center of the screen. Use a stylus or finger to push the center of the “+” until it moves. The “+” moves to upper-left, lower-left, lower-right and upper-right corners. When all five “+” are done the “+” will disappear. The Touch Screen parameter will store at Flash Rom.

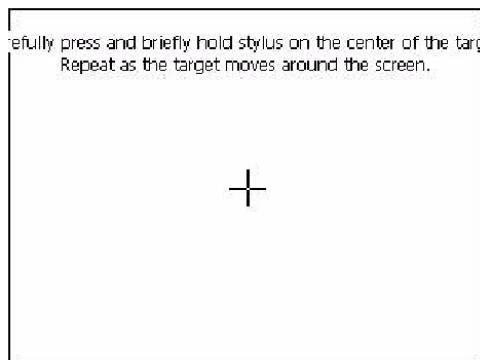

- Boot Loader mode: Load new Windows CE.NET image file.
If the GOT-2570S already load the CE image with boot loader.
Set the DIP SW2 ON then power ON into boot loader mode.
Refer the load Win CE image document.

2.4 CE Requirements

EU directives that apply to the GOT-2570S Series:

- EMC Directive (89/336/EEC, 92/31/EEC, 93/68/EEC)
electromagnetic emissions and immunity
- Machinery Directive (89/392/EEC, 91/368/EEC, 93/44/EEC,
93/ 68/EEC) machine safety

The GOT-2570S Series has been designed to operate satisfactorily in electromagnetic noise (immunity) and without emitting high levels of electrical noise into the environment (emission). The units are designed to meet European Community standards when installed per the wiring instructions in this manual.

Compatibility Standards	<p>The GOT-2570S has been designed to meet electromagnetic compatibility for industrial environments.</p> <ul style="list-style-type: none">• CISPR (EN 55011) Group 1, Class A Radiated Emissions levels• EN50081-2 Generic emission standard, industrial environment (Also US FCC Class A)• EN50082-2 Generic immunity standard, industrial environment
--------------------------------	---

2.5 Dimensions of GOT-2570S

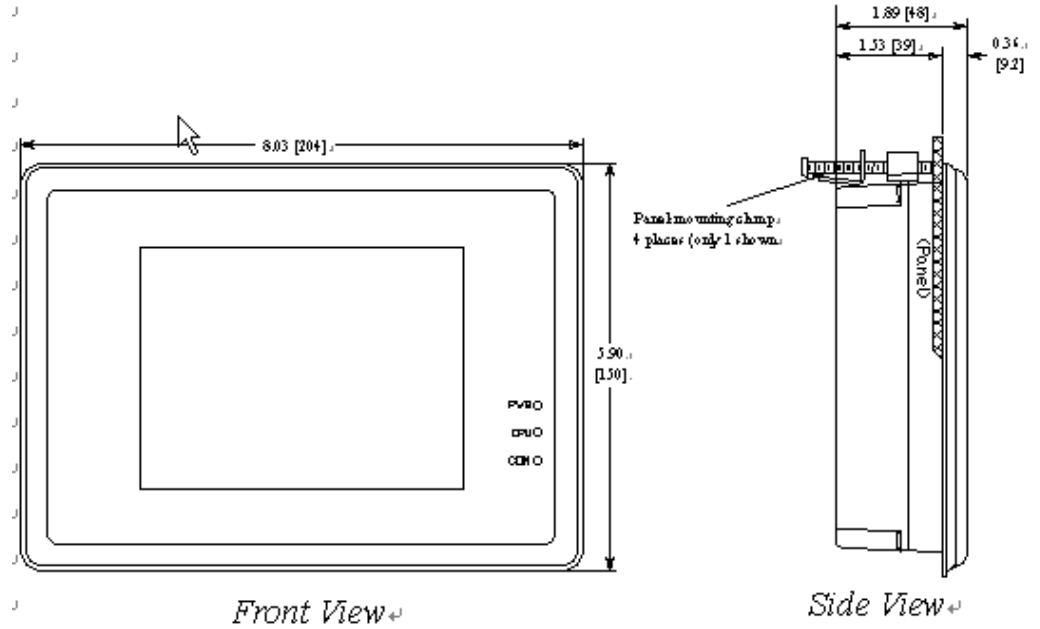

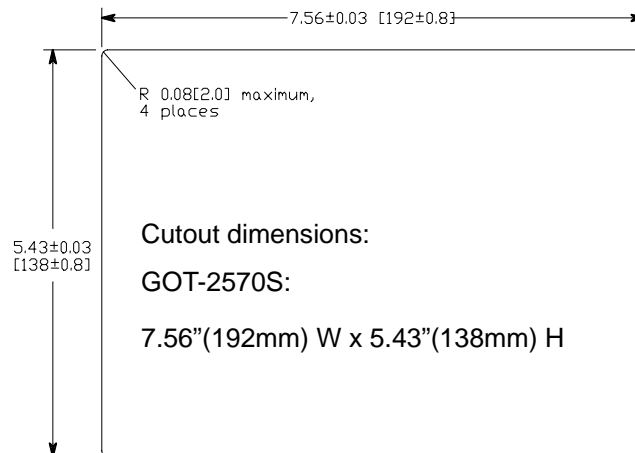
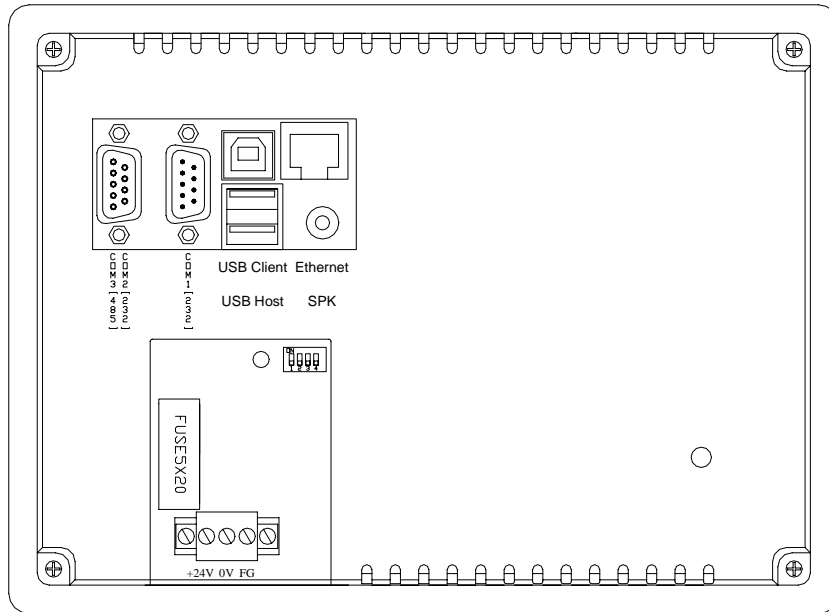

Chapter 3

Windows CE.NET

3.1 Introduction

The GOT-2570S series operator interface terminal is designed to serve on the Windows CE.NET platform. Designed from the ground up for the embedded marketplace, Windows CE.NET delivers a robust real-time operating system for rapidly building the next generation of smart mobile and small footprint devices. With a complete operating system feature set and end-to-end development environment, Windows CE.NET contains everything you need to create a custom Windows CE.NET-based device that requires rich networking, hard real-time, and a small footprint, as well as rich multimedia and Web browsing capabilities.



3.2 Utilities

There are several useful utilities built in the standard Windows CE.NET OS of GOT-2570S:

3.2.1 Soft-Keyboard

The GOT-2570S is dedicated to the small-sized operator interface. It is often inconvenient for users to attach a keyboard to such small machine. Thus, a software keyboard is embedded in the standard Windows CE.NET OS. Upon boot-up, a small keyboard icon will appear on the status bar. Tap this icon by the stylus to activate/hide this Soft-keyboard.



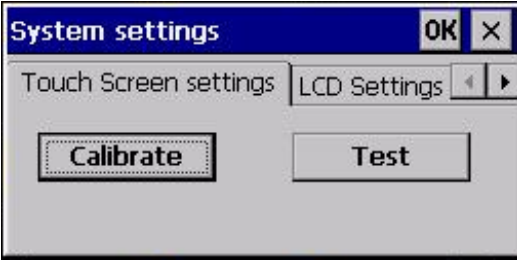

3.2.2 System Settings

GOT-2570S provides an integrated utility for users to make basic setting of the machine.

Step		
1.	Tap the "cecp" icon from Desktop.	
2.	Launch the System Settings Control Panel.	

Touch Screen settings

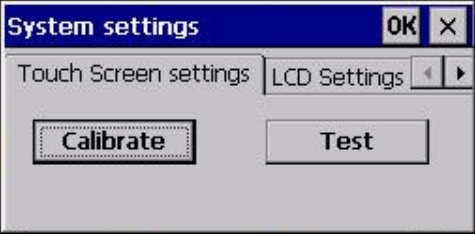
The touch screen calibration can be executed from the Control Panel.

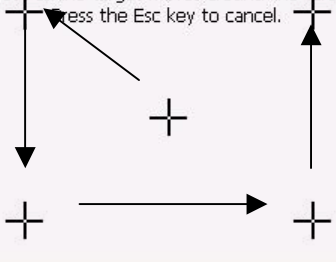
Step		
1.	Launch the System Settings Control Panel.	
	<p>Tapping the "Calibrate" button.</p> <p>The screen will display a "+" sign at the center of the screen.</p>	<p>Fully press and briefly hold stylus on the center of the target. Repeat as the target moves around the screen. Press the Esc key to cancel.</p> 
	<p>Use a stylus or finger to push the center of the "+" until it moves. The "+" moves to upper-left, lower-left, lower-right and upper-right corners. When all five "+" are done the "+" will</p>	<p>Fully press and briefly hold stylus on the center of the target. Repeat as the target moves around the screen. Press the Esc key to cancel.</p> 

	disappear. The Touch Screen parameter will store at Flash Rom.	
--	--	--

Backlight

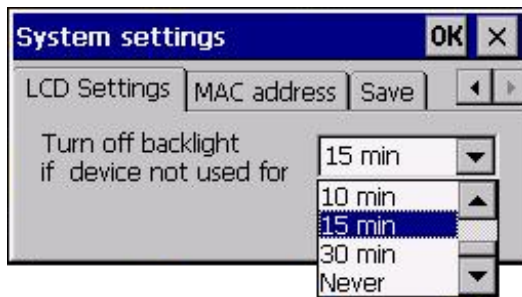

“LCD Settings” page of the **cecpc** provides the function to turn off the LCD backlight, and thus elongates the period of service. For example, if the user wants the backlight turned off automatically after 10 minutes when the device was no longer used. The user must select “10 minutes” in the put down box and then press “OK” button. Then the screen save function is enabled. Once the backlight was turned off, events or perturbations from the touch screen can turn it on.

On the other hand, if users want to disable the screen save function, select “Never” and press “OK” button.

MAC address

The MAC address page the block shows the network MAC address.

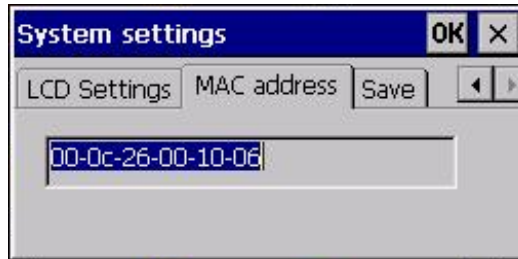

Save

Tap the Save registry button, would save the registry data to the **IPSM** folder. Next time reboot the



GOT-2570S, Windows CE.NET system will use the stored registry data.

Or in GOT-2570S \Windows folder click the "**backupreg.exe**" and it will save the registry data too.

3.2.3 IPSM



IPSM(Intel Persistent Storage Manager)

The IPSM serves as a small capacity hard disk. You can store your data and application in the Flash ROM via IPSM function to prevent unexpected loss of data as power failure. When power is shutdown and cold boot, the data in the Flash ROM area would be saved.

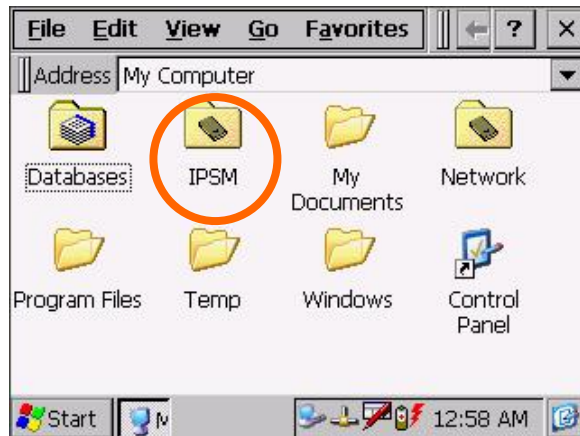

3.2.4 Startup

After the system boot up, the startup execution function would automatically perform. This function is useful for control system to do the initialization processes or some other programs.

Step1: Create "startup" directory in in "\IPSM\".

Step2: Copy executable files or Shortcut to "StartUp" directory, which is created in Step 1.

An alternative way to setup startup files is to make a shortcut and copy it to "IPSM\StartUp". A shortcut can execute a program with Parameters.

Follow the following procedure to create the shortcut (.lnk) file.

A .lnk file is a text file that contains the command line for the linked target, which may be enclosed in double quotation marks, along with the length of that command line. Optionally, you can also pass parameters into the linked target. By default, a .lnk file uses the following format.

```
[number of ASCII characters after pound sign]#[command line]  
[optional parameters]
```

For example, to start MyApp.exe and pass two optional parameters into the application, a sample MyApp.lnk file contains the following.

```
40#\Windows\MyApp.exe parameter1 parameter2
```

3.2.5 Remote Desktop Connection (Windows XP only)



Use Remote Desktop Connection you can remotely control your computer.

To use Remote Desktop, you need the following:

Windows XP Professional installed on your office computer, or whichever computer you plan to operate remotely. This computer is known as the host.

You must first enable the Remote Desktop feature on your office computer so that you can control it remotely from another computer. You must be logged on as an administrator or a member of the Administrators group to enable Remote Desktop on your Windows XP Professional-based computer.

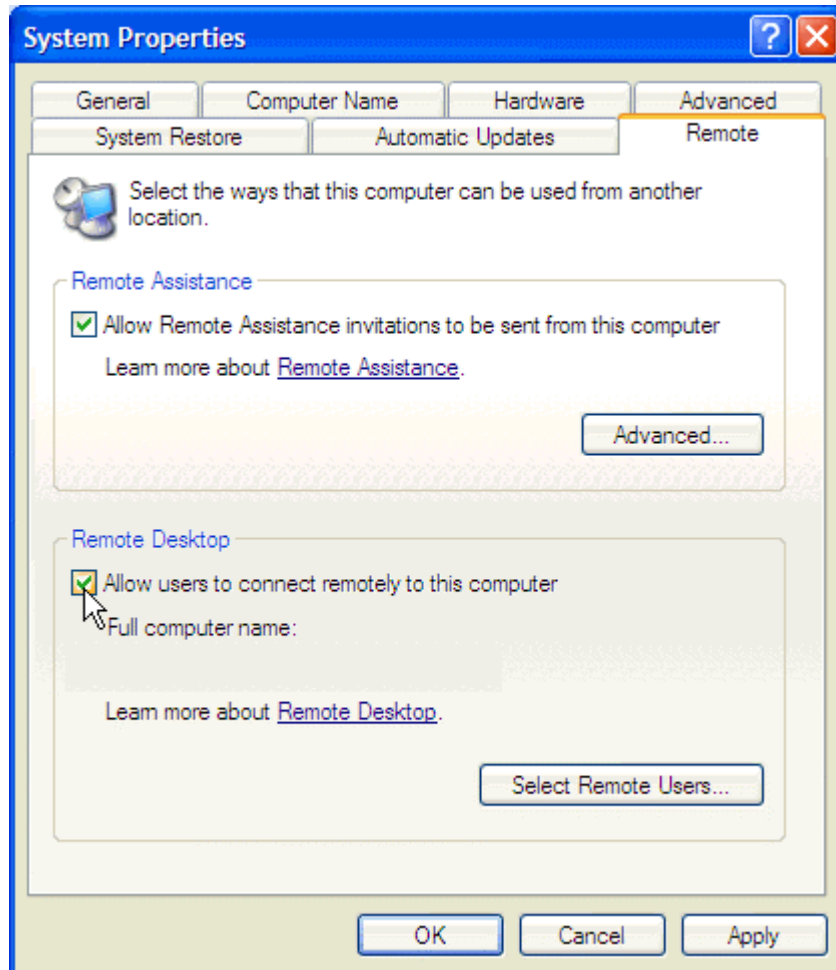

To create a new Remote Desktop Connection

1. Open Remote Desktop Connection.
2. In Computer, type the computer name for your computer running Windows XP Professional that has Remote Desktop enabled and for which you have Remote Desktop permissions.



3. Click **Connect**. The **Log On to Windows** dialog box appears.
4. In the **Log On to Windows** dialog box, type your user name, password, and domain (if required), and then click **OK**. The Remote Desktop window will open and you will see the desktop settings, files, and programs that are on your office computer. Your office computer will remain locked. Nobody will be able to work at your office computer without a password, nor will anyone see the work you are doing on your office computer remotely.

Note: To change your connection settings, (such as screen size, automatic logon information, and performance options), click Options before you connect.

3.3 GOT-2570S Networking

3.3.1 Networking via Ethernet

The GOT-2570S is equipped with a 10Base-T Ethernet controller. To utilize it, change the device name when the GOT-2570S is first turned on.

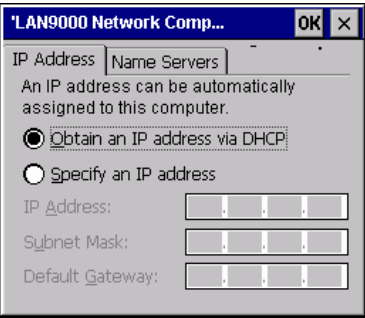
Step		
1	Click "Start/Settings/Control Panel"	
2	Double click "Network and Dial-up Connections"	
3	Find the default device name. Change it to a unique one depending on the plan of individual LANs.	 LAN90001
4	If the GOT-2570S is a node of a LAN with DHCP servers, it is now available.	
5	If the GOT-2570S is a node of a LAN with fixed IP	

	server, please consult with MIS to get specific IP address. Click "Start/Settings/Control Panel". Double click "Network and Dial-up Connections" and update the IP address.	
6	Use the cecp utility "Save registry" to save this changed.	

3.3.2 Networking via USB Client Port

The GOT-2570S can use the USB client to USB host cable connect the USB client port of the GOT-2570S and the USB host port of the host computer as following:

Step		
1	Make sure the Microsoft ActiveSync service is properly installed on the host PC.	 <p>Microsoft ActiveSync</p>
2	Power ON the GOT-2570S. Before the Windows CE.NET boot up, don't connect the USB cable.	

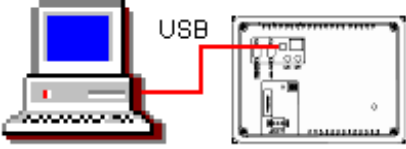
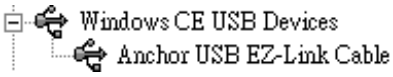
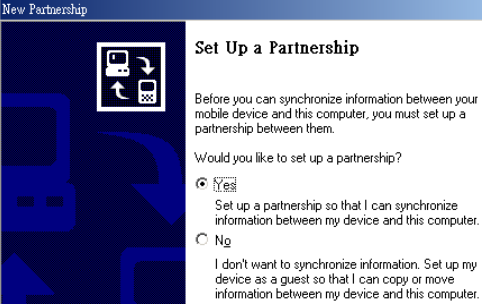
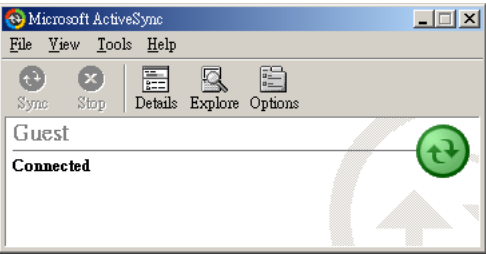
<p>3</p>	<p>Connect the USB client port of the GOT-2570S and the USB host port of the host PC by the USB client to USB host cable.</p>	
<p>4</p>	<p>When the “Add New Hardware Wizard” asks for the driver, select the file D:\GOT-2570S\USBdriver\ wceusbsh.inf</p>	
<p>5</p>	<p>Follow the onscreen instructions to establish a partnership and synchronize your GOT-2570S with your desktop computer.</p>	
<p>6</p>	<p>Now you can synchronize the information between the GOT-2570S and host computer with ActiveSync.</p>	

3.3.3 Web browser

The GOT-2570S built-in Windows CE.NET OS includes Microsoft IE sample. It can be used to browse web pages on World Wide Web via LAN or dial-up connection.



3.4 Application program development

The GOT-2570S is bundled with built-in Windows CE.NET operating system and with Compact Framework. In real applications users need to execute various applications programs on it. However, unlike its other family the Windows CE.NET is a hardware-dependent operating system. That is to say, Windows CE.NET application programs are only portable in the source code level. Users must rebuild the runtime file for a different Windows CE.NET platform even though the source code may not be changed at all.

To develop your application program, you can use two development tools. **Visual Studio.NET or eMbedded Visual C++ 4.0.**

For Visual Studio.NET, you can download newest version of Compact Framework from Microsoft website.

For eMbedded Visual C++4.0; the following development tools must be installed on the PC:

- Microsoft eMbedded Visual C++ 4.0
- Microsoft eMbedded Visual C++ 4.0 Service Pack 1
- GOT-2570S SDK

3.4.1 Microsoft eMbedded Visual C++ 4.0

System Requirements

To use Microsoft eMbedded Visual C++ 4.0 you need the following:



- A desktop computer with a Pentium-II class processor, 450 MHz or faster

- Microsoft Windows® 2000 Professional SP2, Microsoft Windows 2000 Server SP2, or Microsoft Windows XP Professional.
- 96 MB (128 MB recommended) memory for Windows 2000 Professional or Windows XP Professional. 192 MB (256 MB recommended) memory for Windows 2000 Server.
- CD-ROM drive required
- VGA or higher-resolution monitor. A Super VGA (800 x 600 or larger) monitor is recommended.
- Mouse or compatible pointing device.
- 200 MB hard disk space.

3.4.2 GOT-2570S SDK

The GOT-2570S SDK provides developers with access to an extensive set of functions that are specific to the GOT-2570S hardware.

Installing the GOT-2570S SDK

Step		
1.	<p>Download or from GOT-2570S SDK CD find the GOT-2570S_SDK.msi file.</p> <p>Double click the file's name start the Setup Wizard.</p>	
2	<p>The installer will be prompted for acceptance of a license agreement.</p> <p>Following that, the SDK should install itself automatically on the host machine without further operator intervention.</p>	

3	<p>When installation is complete the following message should appear: “Completing the GOT-2570S Setup Wizard”. The installer must press the “Finish” button in the install window to exit.</p>	
---	--	--

Appendix A

Example Program

The GOT-2570S offers loop back test program for two comports. Please select the program D:\GOT-2570S\Example\Serial Test.

Serial port loop back test program

Before running the program, you need to connect two comports of the GOT-2570S.

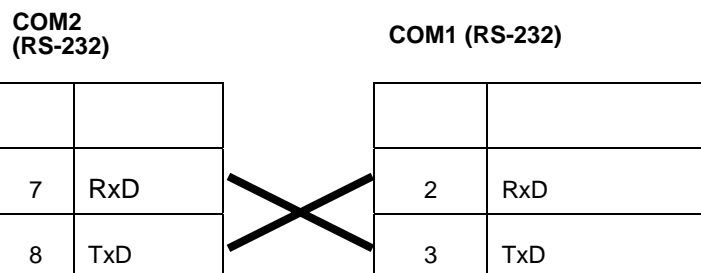

This page does not contain any information.

Appendix B

How to Update WindowsCE image

If you want to update new WindowsCE image to GOT-2570S, you can follow the procedure.

1. Download newest version of WindowsCE image from AXIOMTEK's website. www.axiomtwk.com.
2. Save new WindowsCE image into CompactFlash card and rename it to "nk.bin".



3. Set the DIP switch as follows.

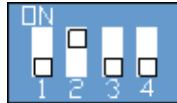

4. Power on the GOT-2570S. Then, it updates GOT-2570s's image and automatic reboot and into Windows CE.

This page does not contain any information.

Appendix C

How to use development tools- eMbedded C++4.0

The following procedure will show you how to use development tools-eMbedded C++4.0.

1. Before you start to develop the application program, you need to install following three S/W to Host PC.
 - (1) USB driver in the driver CD.
 - (2) eMbedded C++ 4.0
 - (3) Microsoft ActiveSync. software
 - (4) SDK (Software Development kit) in the driver CD.

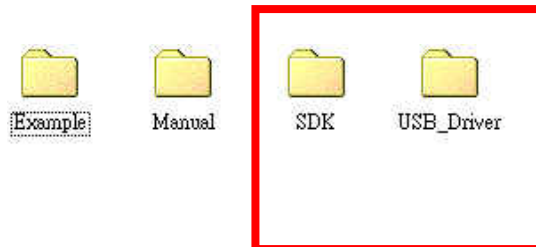

2. Plug synchronized cable which is in the package to the USB client port of the GOT-2570S.



3. Run Microsoft ActiveSync. software.



4. Select "No"



5. Host PC synchronizes to GOT-2570S. Click the item "Explore" and fine all folders in the GOT-2570S.

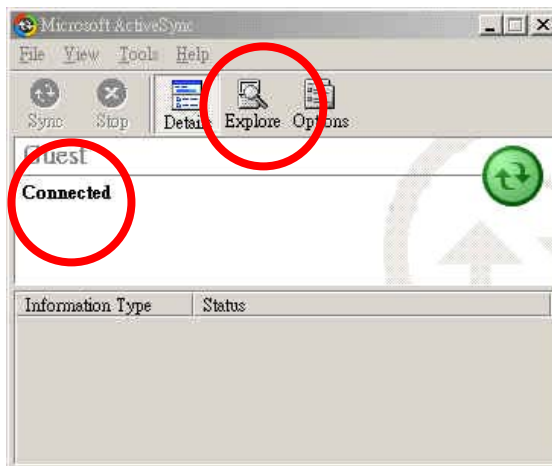



6. If you plug the CompactFlash card in the GOT-2570S. You can find out the folder "StorageCard" in GOT-2570S.



7. Run eMbedded VC++4.0 in host PC..

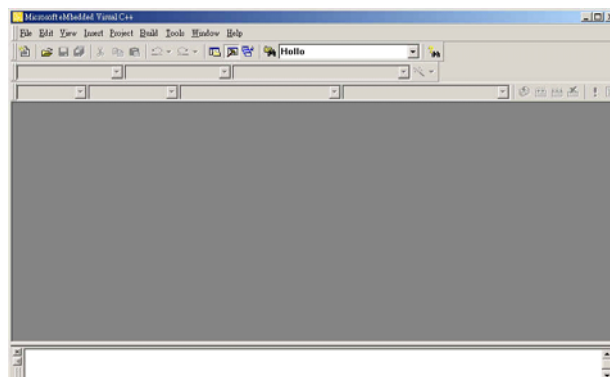

8. Open a new project

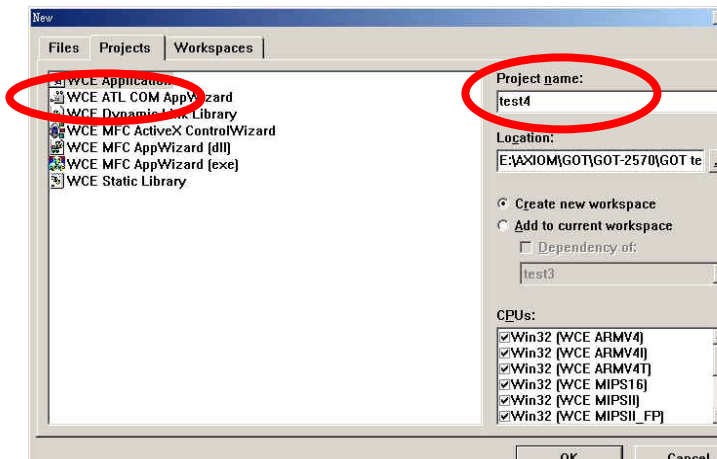

9. Select all CPUs.

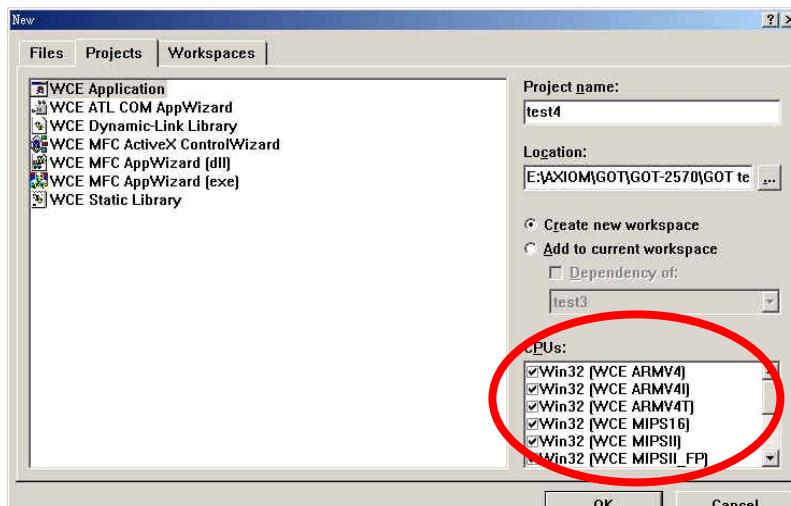

10. If you install GOT-2570S/2770S's SDK successfully, you can select GOT-2570S/2770S in the item. Then, click "Run" to compile your application program into ".exe" file.

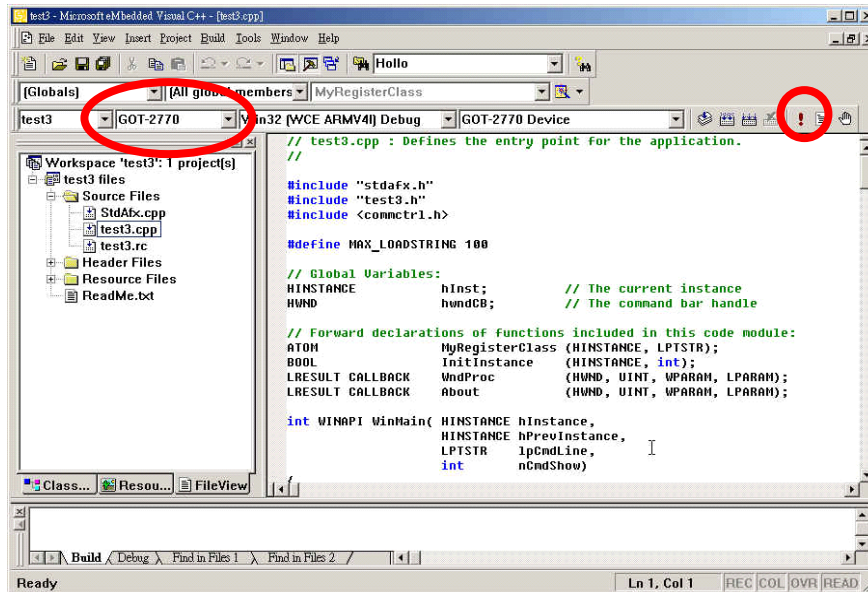

11. The ".exe" file is being sent to the GOT-2570S sync. You can find it in GOT-2570S.

