

High Efficiency PC/104 Vehicle Power Supply

DC to DC Convertor

Manufactured by
TRI-M ENGINEERING

Engineered Solutions for Embedded Applications

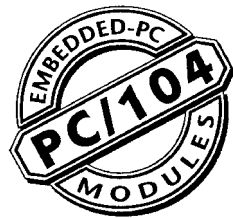
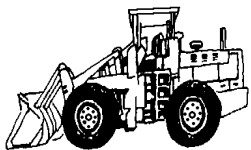

Technical Manual



P/N: HE104MAN-V5
Revision: 09/99



Unit 6, 1301 Ketch Court
Coquitlam, British Columbia, V3K 6X7
Canada

<http://www.Tri-M.com>
Tel 604-527-1100 - 800-665-5600
Fax 604-527-1110



PREFACE

This manual is for integrators of applications based on the PC/104 embedded systems format. It contains information on hardware requirements and interconnection to other PC/104 embedded electronics.

DISCLAIMER

Tri-M Engineering makes no representations or warranties with respect to the contents of this manual, and specifically disclaims any implied warranties of merchantability or fitness for any particular purpose. Tri-M Engineering shall under no circumstances be liable for incidental or consequential damages or related expenses resulting from the use of this product, even if it has been notified of the possibility of such damages. Tri-M Engineering reserves the right to revise this publication from time to time without obligation to notify any person of such revisions. If errors are found, please contact Tri-M Engineering at the address listed on the title page of this document.

COPYRIGHT © 1996 TRI-M ENGINEERING

No part of this document may be reproduced, transmitted, transcribed, stored in a retrieval system, or translated into any language or computer language, in any form or by any means, electronic, mechanical, magnetic, optical, chemical, manual, or otherwise, without the express written permission of Tri-M Engineering.

Table of Contents

CHAPTER 1 - INTRODUCTION	1-1
1.1 GENERAL DESCRIPTION	1-1
1.2 FEATURES	1-2
1.3 SPECIFICATIONS	1-3
CHAPTER 2 - CONFIGURATION AND INSTALLATION	2-1
2.1 Introduction	2-1
2.2 Power Considerations	2-1
2.3.1 Main Input Power Connector	2-2
2.3.3 Output Power Connector	2-2
2.3.2 Battery Power Connector (Optional)	2-2
2.3.5 Onboard DC "Boost" Converter (Optional)	2-3
2.4 Bus Termination (Optional)	2-3
2.5 Installation onto PC/104 modules	2-3
2.6 Jumper Selection	2-4
2.6.1 LED Jumper Enable/Disable	2-4
2.6.2 +5VDC Low Q / Noise (Q=quiescent)	2-4
2.6.3 +12VDC Low Q / Noise	2-4
2.6.4 Mezzanine Expansion Headers	2-5
2.6.4 PC/104 Bus Interrupts (optional)	2-5
2.8 Remote On/Off	2-6
2.9 Power Management Controller PM104 (optional)	2-7
2.10 Low Input Alarm	2-8
2.11 HE104 Efficiency and Heat Dissipation Calculation	2-8
CHAPTER 3 - THEORY OF OPERATION	3-1
3.1 Input power protection:	3-1
3.2 Switching regulator, +5VDC	3-1
3.3 Switching regulator, +12VDC	3-2
3.4 Charge Pumps	3-2
3.5 Filter Capacitors	3-3
3.5 Bus Termination (Optional)	3-4
APPENDIX	APPENDIX-1
HE104, +5V Regulator Block Diagram	APPENDIX-1
ADVANTAGES OF USING AC TERMINATION	APPENDIX-3
Installation Hints for the HE104 Power Supply	APPENDIX-4
Vehicles Are An Electronics Nightmare	APPENDIX-4

CHAPTER 1 - INTRODUCTION

1.1 GENERAL DESCRIPTION

The HE104 multiple output DC to DC 50 watt converter is a high efficiency, high performance unit that can be supplied with +5V, +12V outputs only, or can include features such as Power Management, Universal Battery Charger, AC Bus termination, -5V output, -12V output, and custom output voltages from -42V to +42V. The HE104 is designed for low noise embedded PC/104 computer systems, has a wide input range of 6- 40V(>6:1) and is ideal for battery or unregulated input applications. The HE104 is specifically designed for vehicular applications and has heavy duty transient suppressors (5000W) that clamp the input voltage to safe levels, while maintaining normal power supply operation.

The HE104 is a state-of-the-art MOSFET based design that provides outstanding line and load regulation with efficiencies up to 95 percent. Organic Semiconductor Capacitors provide filtering that reduces ripple noises below 20mV. The low noise design makes the HE104 ideal for use aboard aircraft or military applications or wherever EMI or RFI must be minimized. The +5VDC and +12VDC outputs are controlled by a constant off-time current-mode architecture regulator that provides excellent line and load transient response.

The +12VDC boost regulator uses the +5VDC as input power, and therefore can operate without dropout from 6 to 40V input, and supply 2A. The +5VDC output is protected from output shorts by a high speed pulse-by-pulse current limit circuit. The +12VDC output is protected from shorts by the current limiting of the +5VDC controller.

A "plug-in" Universal Battery Charger (BC104) is available for the HE104 to charge Lead-Acid, NiCd, and NiMH batteries. Charge currents can be up to 1.5A, and battery charging voltages from 6 to 40V.

The Power Management controller (PM104) allows timed on/off control of the HE104, bus interrupts on impending power failure, current limit setting and intelligent charge termination for the BC104.

The HE104 is provided in a PC/104 form factor compliant size, and includes the 8bit, and 16bit PC/104 expansion bus header. All generated voltages are provided to their related power supply pins on the PC/104 expansion bus, and are all also available for off-board use through a screw terminal block. PC/104 AC bus termination is optionally available on the HE104, which provides the "cleanest" possible signals on the PC/104 bus.

The HE104 can be configured to meet almost any power supply need for embedded PC/104 applications, whether that be a simple +5V application, or providing power for back lighted LCD panels, or a full UPS (un-interruptible power supply configuration).

1.2 FEATURES

- M DC to DC convertor for PC/104 bus equipped products.
- M "Load Dump" transient suppression on input power supply.
- M Operates from 6VDC to 40VDC input.
- M "Stacks" onto the PC/104 bus.
- M Passthrough or non-passthrough 8 bit and 16 bit versions.
- M 5V, 12V standard, -12V, -5V, and battery charger optional.
- M Highly compact, 100 percent PC/104 conforming.
- M "AC" bus termination available.
- M Screw terminals provide off-board connection to output voltages.
- M Remote "logic level" On/Off control.

1.3 SPECIFICATIONS

Power Supply Specifications	
Model	HE104
5V output*	10 A
12V output	2 A
-5V output	400mA
-12V output	500mA
Input Voltage Range	6 to 40V
Load Regulation **	<60mV
Line Regulation **	±40mV
Output temp. drift **	<40mV
Switching Freq.	75kHz
Max. Input Transient	125V for 100msec
Output Ripple**	<20mV
Conducted Susceptibility **	>57db
Efficiency**	up to 95%
Temp Range	-40 to 85C
Quiescent current***	2mA
Size, PC/104 form factor****	3.55"W. x 3.75"L x 0.6"Height

- *Current rating includes current supplied to 12V, -12V, & -5V regulators.
- **Measured on the 5V output.
- ***LEDs disabled, Low Quiescent mode enabled.
- ****Not including passthrough pins.

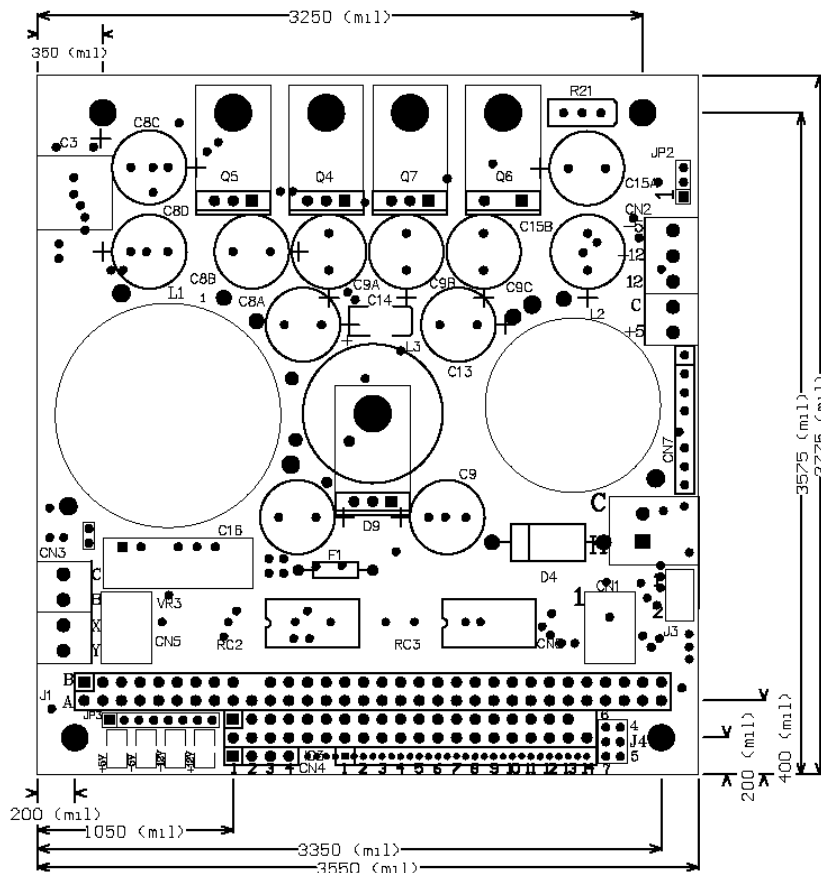
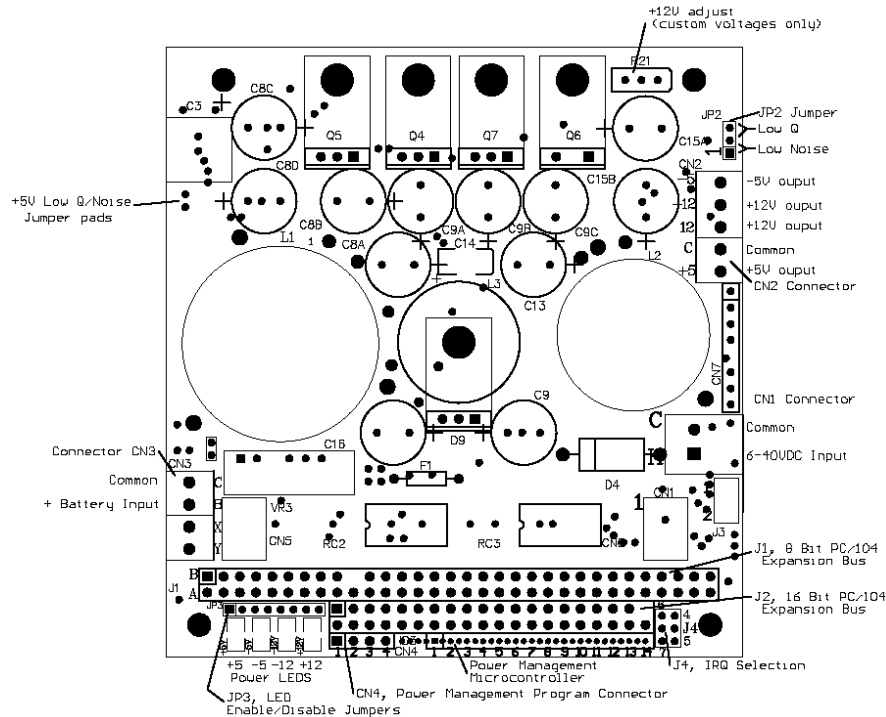

Figure 1-1, HE104 Dimensions
1000mil = 1 inch

CHAPTER 2 - CONFIGURATION AND INSTALLATION

2.1 Introduction

This chapter describes the configuration and installation of the HE104 power supply. In addition, section 2.2 provides a formula to calculate the available +5VDC. Figure 2-1 shows the HE104 connectors, jumper and other options.



2.2 Power Considerations.

$$Usable +5V output = 10A - \frac{(I[-5] + I[-12]) * 2.4 + I[12] * 2.4}{0.8}$$

The +5V switching regulator is rated at 10A maximum output, however the +5V output supplies power to the +12, -5, and -12VDC regulators. To obtain the usable range of +5V output, “derate” according to the use of +12, -5, and -12VDC. Use the following formulae to calculate the maximum usable output.

Where: $I[-5]$ = -5VDC current load
 $I[-12]$ = -12VDC current load
 $I[12]$ = 12VDC current load

Assuming 90 percent convertor efficiency (actual efficiency may vary).

2.3.1 Main Input Power Connector

Input power is connected to the “pluggable” block, CN1, which is removable from the socket connector on the circuit board. The power supply accepts DC input voltages in the range of 6VDC to 40VDC.

Unregulated vehicle power is connected as follows:

- Terminal 1: “hot” polarity
- Terminal 2: Common (0VDC)

!! CAUTION !!

To allow operation at the lowest possible input voltages (6VDC), and for the best efficiency, **NO input “reverse-polarity” input diode is provided on the HE104 ordered without battery charger option.** If reverse-polarity input diode is required, add “RPD” to the HE104 part#

- Example HE104-512-16-RPD

Note: Adding the Reverse Polarity Diode (RPD) results in an increased power loss. For heat dissipation estimation please refer to section 2.11.

2.3.2 Output Power Connector

Output power is available for non-PC/104 use via connector CN2.

- Terminal 1: +5VDC output
- Terminal 2: Common
- Terminal 3: +12VDC
- Terminal 4: -12VDC output (optional)
- Terminal 5: -5VDC output (optional)

2.3.3 Battery Power Connector (Optional)

Batteries are connected to the screw terminal block, CN3. The HE104 accepts DC battery voltages in the range 6.5V to 40VDC through the Battery Power Connector. Two external signals can be connected to the battery terminal block for use by add-on modules plugged into the mezzanine header connectors. Connect to the HE104 Battery Terminal Block as follows:

- Terminal 1: Common of battery
- Terminal 2: Positive Battery Terminal
- Terminal 3: External signal 1
- Terminal 4: External signal 2

Note: When Optional Plug-IN Boost regulator (VR3) is ordered, batteries or external signals cannot be connected to CN3. See section 2.3.5

2.3.4 Onboard DC “Boost” Converter (Optional)

An optional converter boost pump, model NMH05XXS (XX = output voltage, $\pm 5V$, $\pm 9V$, $\pm 12V$, $\pm 15V$) can be installed in location VR3 to provide custom output voltages. The NMH charge pumps have an isolated positive and negative output, and a maximum 2 watt capacity. A minimum load of 10 percent is required for proper operation. By referencing (connecting) the charge pump to other voltages, the user can create +/- supplies, elevated and negative voltages (ie. The charge pump “0V” is not connected to the HE104 common).

- Terminal 1: Common of battery
- Terminal 2: -V output
- Terminal 3: 0V
- Terminal 4: +V output

Example: NMH0515S ($\pm 15V$) can generate the following voltages:

- $\pm 15V$ by connecting NMH “0V” to HE104 common
- $-30V$ by connecting NMH +V to Common
- $+30V$ by connecting NMH -V to Common
- $+42V$ by connecting NMH -V to $+12V$ output

Note: When batteries or external signals are connected to CN3 the Plug-IN Boost regulator (VR3) cannot be installed. See section 2.3.4

2.4 Bus Termination (Optional)

“AC” bus termination minimizes power consumption, while improving the reliability of the bus. The resistor/capacitor combination only conducts current during the few nanoseconds when the bus signal is changing state. See appendix “B”.

2.5 Installation onto PC/104 modules

The PC/104 bus on the HE104 is keyed according to the standards as set out by the PC/104 Consortium Guidelines. Pin B10 of the 8-bit bus, and pin C20 of the 16-bit bus are removed, but the female sockets are not “plugged”. It is highly recommended the female sockets be plugged to prevent mis-alignment with other PC/104 modules, however this is left up to the customer.

Because of the large number of pins and sockets (104 total) in the PC/104 bus, caution must be used in separating the PC/104 modules to prevent bending the pins, or “spearing” the person separating the modules. Tri-M Engineering recommends the use of the PC/104 removal tool, model #5535, available from Tri-M Engineering.

2.6 Jumper Selection

This section describes the function of each jumper, the location of it, the default setting, and how to change it.

2.6.1 LED Jumper Enable/Disable

These jumpers allow the LEDs to be disabled. This is most likely to be used when absolute minimum power consumption must be maintained, such as when operating off a limited battery source.

The location of each LED jumper is immediately “behind” each LED.

Each LED is enabled by factory default. To disable any LED, remove the LED jumper (or cut the small PCB trace if no jumper is installed) associated with the LED. To re-enable any LED, re-install the associated jumper (or solder a short jumper wire between each of the jumper pads).

2.6.2 +5VDC Low Q / Noise (Q=quiescent)

This jumper allows the +5VDC regulator IC1 to be changed from low ripple noise mode into the low quiescent power mode. This option is most likely to be used when absolute minimum power consumption must be maintained, such as when operating off a limited battery source. It is recommended that the +12VDC Low Noise mode be selected whenever the +5VDC Low Q. mode is not required.

The PCB jumper trace is located on the “bottom” of the circuit board, between two pads. Location of the jumper is identified on the left side of the heat sink by “Low Q/Noise”. Refer to figure 2.1 for exact location of +5VDC Low Q/Noise jumper.

The factory default setting for Low Q/Noise is for low ripple noise. To change the factory default setting to Low Q operation, the small PCB trace jumper trace must be cut using the tip of a sharp knife. To return to Low Noise operation, solder a jumper connecting the jumper pads.

2.6.3 +12VDC Low Q / Noise

This jumper allows the +12VDC regulator IC1 to be changed from low ripple noise mode into the low quiescent power mode. This option is most likely to be used when absolute minimum power consumption must be maintained, such as when operating off a limited battery source.

The PCB jumper trace is located on the “bottom” of the circuit board, between two pads of jumper block JP2. Location of the jumper is identified on the right side of the heat sink by “Low Q” with “Low Noise” directly below it. Refer to figure 2.1 for exact location of +12VDC Low Q, Low Noise jumper.

The factory default setting for Low Q, Low Noise is for low ripple noise. To change the factory default setting to Low Q operation, the small jumper connecting JP2-1 to JP2-2 must be cut using the tip of a sharp knife, and solder a jumper across the pads JP2-2 to JP2-3. To return to Low Noise operation, remove the jumper between JP1-2 and JP2-3 and re-install the jumper connecting

JP2-1 to JP2-2.

2.6.4 Mezzanine Expansion Headers

The mezzanine expansion headers are used for installation of the optional battery charger. The mezzanine expansion headers can also be used for custom output voltages such as Vee for LCD panels. If custom output voltages are required please contact Tri-M Engineering.

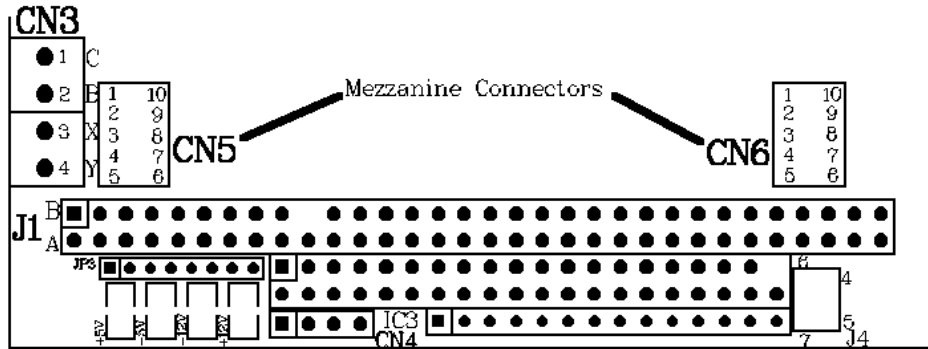

Figure 2.3, HE104 Mezzanine Connectors

Connector CN5 Pinout		Connector CN6 Pinout	
1. +5V	10. +5V	1. PM104-P1	10. Main Pwr. Input
2. Common	9. Common	2. Common	9. Common
3. +Battery Input	8. Main Pwr Input	3. PM104-P7	8. PM104-P2
4. Ext. Signal 1	7. +12V	4. PM104-P6	7. PM104-P3
5. Ext. Signal 2	6. -5V	5. PM104-P5	6. PM104-P4

2.6.5 PC/104 Bus Interrupts (optional)

Interrupts to the PC/104 bus require the installation of the optional power management microcontroller (PM104). The PM104 can be programmed to provide indication of loss of input power, low battery voltage, or to provide indication to the PC/104 CPU to begin an orderly shutdown of program operation.

Two separate interrupt requests can be generated, and each interrupt request will remain active until the cause of the interrupt request returns to normal. Interrupt Int1 can be set to IRQ6 or IRQ7, while interrupt Int2 can be set to IRQ4 or IRQ5 by installing an appropriate jumper on jumper selections block J4. Jumper block J4 is located adjacent to the PC/104 bus, on the opposite side where the power LEDs are located.

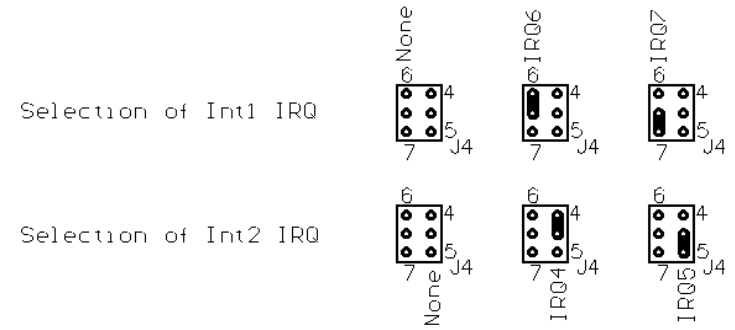

Figure 2-2, Interrupt IRQ Selection

2.7 Remote On/Off

This input allows the HE104 to be remotely turned on or off by a low power logic level signal. An ideal use of this feature is allow the PC/104 host computer to “shutdown” before power is removed. A simple timer triggered when the ignition is turned off, tells the HE104 to turn off, but only after timing out. In the meantime, the ignition signal (buffered of course) connected to the PC/104 host computer would give it time to properly shut down any programs that were running.

If the power management microcontroller PM104 is installed, it can be used to generate a PC/104 bus interrupt to signal the PC/104 CPU to shut down running programs, then the PM104 can be programmed to power down the HE104 after a preset time.

- Connect the ignition signal (through a 10K resistor with a transient 24V suppressor to ground) to CN6 pin 8. Use of Int2 is not permitted if CN6 pin 8 is used as an I/O pin.
- Use Int1 if PC/104 bus interrupt required
- Program your application to recognize IRQ6 or IRQ7 to shut down program operation when activated.
- Program PM104 to initiate bus interrupt when preset time expired.

The maximum voltage input level for the Remote On / Off input is 7VDC. No transient protection is provided on this input to the HE104, therefore ensure adequate signal level clamping, and transient suppression is provided and the connected signal. The Remote On/Off threshold voltage is 2VDC.

The Remote On/Off input can be accessed on connector CN6-1, or IC3-8 if PM104 is not installed. Connect common to CN6-2 OR IC3-2.

2.8 Power Management Controller PM104 (optional)

The Power Management Controller (PM104) is a microcontroller “plug-in” module for timed on-off control of the HE104, control of the optional battery charger, and generation of interrupts to the PC/104 host CPU. The PM104 is programmed in a high level “controller basic language” called PBasic. To program the PM104, connect the program cable (PM104-Cable) to connector CN4 on the HE104, and to the parallel port of any PC compatible computer. PM104 programs can be directly downloaded, or updated using the PM104 utility software.

Connector CN4 Pinout, PM104 Program Connector

- Terminal 1: PM104 Power (leave disconnected if HE104 powered)
- Terminal 2: Common, connect to pin 25 of PC parallel port
- Terminal 3: PC0, connect to pin 11 (busy) of PC parallel port.
- Terminal 4: PCI, connect to pin 2 (DO) of PC parallel port.

Table 2.1, PM104 Pin Number and I/O Functions

IC3 Pin#	PM104 Microcontroller Description (IC3)	HE104 Function or Connection	Battery Charger Function
1	PM104 Supply Voltage	HE104 Supply Voltage	
2	Common	Common	
3	PC0 (PC out)	Connector CN4-3	
4	PCI (PC in)	Connector CN4-4	
5	+5V input/output	No connection	
6	Reset	No connection	
7	P0 (Input/Output Pin 0)	Input Voltage Status	
8	P1 (Input/Output Pin 1)	HE104 On/Off Control	HE104 On/Off Control
9	P2 (Input/Output Pin 2)	Connector CN6-8	Analog/Digital Chip Select
10	P3 (Input/Output Pin 3)*	Int2, Connector CN6-7*	Spare* Input/Output
11	P4 (Input/Output Pin 4)	Connector CN6-6	Data Input/Output Line
12	P5 (Input/Output Pin 5)	Connector CN6-5	Data Clock
13	P6 (Input/Output Pin 6)*	Int1, Connector CN6-4*	Spare* Input/Output
14	P7 (Input/Output Pin 7)	Connector CN6-3	Analog Current Limit

* If Interrupt function is not used, this PM104 line can be used for general purpose Input/Output.

2.9 Low Input Alarm

This output signals the Power Management circuit (PM104) or external circuitry that main input power has failed. The Low Input Alarm signal has a 100K current limiting resistor in series.

If the PM104 is not installed, then external circuitry can access the Low Input Alarm output on connector IC3-7.

2.10 HE104 Efficiency and Heat Dissipation Calculation

The average efficiency of the HE104 is 90 percent for the +5V output, but efficiency at any specific input voltage, output load, and ambient temperature may be higher or lower. Typical efficiency is between 88 and 94 percent. Best efficiency occurs at mid input voltage (16 to 18V), mid output loads (20 to 30 watts), and low heat sink temperature. As the input voltage, and output load is determined by the system application, this leaves only the heat sink temperature that System Integrators adjust to maximize efficiency. Either forced flow fans, or thermally coupling the HE104 heat sink to enclosures or external heat sinks can improve the efficiency of the HE104. An improvement of 3 to 4 percent can be obtained by good thermal management and results is 35 percent less heat dissipated.

- A. Heat Dissipated (HD) = Input Power - Actual Load
 where Input Power = Input Voltage * Input Current
 and Actual Load = +5V load +(12V load) +(-5V load) +(-12V load)
 (Load measured in watts)
- B. Estimated Heat Dissipated (ESD) can be calculated based on 90 percent efficiency:
 $EHD = \{+5V \text{ load} + [(+12V \text{ load}) +(-5V \text{ load}) +(-12V \text{ load})]/0.9\} * 0.1$
- C. If the Battery Input option is installed or the Reverse Diode Protection (RDP) option installed addition heat will be dissipated.
 $RDPD = \text{Total Load}/\text{Input Voltage} * 0.7V \text{ (diode drop)}$
- D. If the Battery Charger Option is installed the heat dissipated from it will vary according to the current charge current. Maximum heat dissipation will occur when charging at maximum current, and can be estimated by:
 $BCD = \text{Maximum Charge Current} * \text{Charge Voltage} * 0.2$
 (Based on 80 percent efficiency)

CHAPTER 3 - THEORY OF OPERATION

3.1 Input power protection:

Input power is connected to the screw terminal block, CN1, which is removable from the socket connector on the circuit board. A 10 ampere 'pico' fuse F1 limits the current draw from the power source. A series of devices, (toroid Coil L3, transorb D4, and filter capacitors, C8A, C8B, C8C and C8D) filters and clamps the input power.

Transorb D4 is a 5KVA, heavy duty transient suppressor. Transorb D4 provides "zener" type protection and has an avalanche voltage of 43V. It is electrically located "before" fuse F1 to prevent activation of the fuse during a "load dump" or large transient. Sustained voltages greater than the avalanche voltage must not be applied or transorb D4 will fail.

3.2 Switching regulator, +5VDC

A switching regulator IC1, generates the +5VDC output, operating in a "buck" mode synchronous switching regulator configuration using inductor coil L1, upper mosfet Q4, lower mosfet Q5, schottky diode D8, input filter capacitors C8A, C8B, C8C and C8D, and output filters capacitors C2, C3, C9A, C9B, and C9C. Regulator IC1, is a current mode controller, and adjusts the "switching cycle" by the sensed current rather than directly by the output voltage. Control of the output voltage is obtained by using the output of a voltage sensing error amplifier in regulator IC1 to set the current trip level. Operating frequency is set by capacitor C5.

A total of 15 amperes can be supplied to the connected +5VDC load, to the inputs of the +12VDC regulator, and the -5VDC, and -12VDC charge pumps and invertors. The +5VDC power is available on the PC/104 expansion bus, screw terminal connector CN2.

At startup, a low dropout 4.5V source in regulator IC1 provides the operating voltage Vcc for the mosfets, and control circuitry. After startup, regulator IC1 uses the output from the +12VDC regulator to power the mosfets and control circuitry to improve efficiency .

A low quiescent power mode uses the built-in "burst mode" feature of the regulator IC1. Low quiescent power mode reduces power by placing regulator IC1 in a "sleep" mode whenever the output level is within the burst mode voltage limits. As soon as the +5VDC output drops below the burst low level voltage, "normal" switching regulator operation begins and continues until the +5VDC output reaches the upper burst level voltage. Then regulator IC1 is put into "sleep" mode again. When low quiescent power mode is enabled, regulator IC1 burst mode operation will begin at approximately 1.5 ampere output. The output ripple when regulator IC1 is operating in burst mode is 50millivolts.

The +5VDC regulator functions fully down to 6VDC input. Below 6VDC input the +5VDC output will track the input and have a "droop" proportional to the resistive losses on the HE104. The HE104 operates up to 40VDC input.

3.3 Switching regulator, +12VDC

A switching regulator IC2, generates the +12VDC output, operating in a "boost" mode switching regulator configuration using inductor coil L2, mosfet Q7, schottky diode Q6, input filter capacitors C9A, C9B, and C9C, and output filters capacitors C15A, and C15B. Capacitors C9A, C9B, and C9C work as an output filter for the +5VDC, and as an input filter for the +12VDC regulator IC2. Regulator IC2, is a current mode controller, and adjusts the "switching cycle" by the sensed current, rather than directly by the output voltage. Control of the output voltage, sensed by resistors R18 and R19, is obtained by using the output of a voltage sensing error amplifier in regulator IC2 to set the current trip level. If a custom output voltage is ordered, variable resistor R21 (in series with R19) will adjust the feedback voltage. Operating frequency is set by capacitor C22.

A total of 2 amperes can be supplied to the connected +12VDC load, and the -12VDC invertor. The +12VDC power is available on the PC/104 expansion bus, and screw terminal connector CN2.

A low quiescent power mode uses the built-in "burst mode" feature of the regulator IC2. Low quiescent power mode reduces power by placing regulator IC2 in a "sleep" mode whenever the output level is within the burst mode voltage limits. As soon as the +12VDC output drops below the burst low level voltage, "normal" switching regulator operation begins and continues until the +12VDC output reaches the upper burst level voltage. Then regulator IC2 is put into "sleep" mode again. When low quiescent power mode is enabled, regulator IC2 burst mode operation will begin at approximately 0.3 ampere output.

Note: Low quiescent power mode should only be selected if absolute minimum current consumption is required. At output currents above 0.3 amperes, low quiescent power mode will not increase efficiency, and may result in regulator IC2 jumping into "burst mode" resulting from noise on the +12VDC output. No harm to IC2 will occur from this, but increased ripple on the +12VDC output will occur.

3.4 Charge Pumps

The -12VDC is generated by first charging capacitor C13 to +12VDC when mosfet Q7 is turned off. Diode D6 provides a path to common for the charge current. When mosfet Q7 is turned on the charge on C13 is transferred to the -12VDC output capacitor C9 through mosfet Q10. Mosfet Q10 is synchronized with mosfet Q7 through a level shifter (C19, D13, and R26).

The -5VDC is generated by a "secondary" coil on inductor L1. By design, the inductor in a buck regulator will maintain the output voltage across it. The secondary winding having the same number of turns as the primary, will also have the same output voltage across it. By referencing the positive end of the "secondary" coil to Common, -5V is created. Diode D3, and capacitor C14 improve the regulation. Capacitor C16 provides output filtering. The -5V is rated at 500mA, however for best regulation, the -5V load should be limited to 10 percent of the +5V load.

3.5 Filter Capacitors

At 10kHz and above, the impedance of filter capacitors is essentially their effective series resistance (ESR), and this parasitic resistance limits the filtering effectiveness of the capacitors. Since the filter capacitors must absorb the “switching ripple” current, capacitors with high ESR values will quickly overheat. For example, a capacitor with a 100mOhm ESR which is absorbing a 5A ripple current, will dissipate 2.5W heat.

The capacitors used for filtering in the HE104 are organic semiconductor (OS-CON) capacitors. The OS-CON is an aluminum solid capacitor with organic semiconductive electrolyte used as cathode conductive materials. The OS-CON has many advantages over the conventional electrolytic:

- very low ESR values, less than 8 times lower for same package.
- high ripple current rating, over 4 times higher for same package.
- no degrade in operation at extended low temperatures. (ESR value of conventional electrolytics can increase 25 fold at -40C).

The life expectation for a filter capacitor is typically 2,000 to 6,000 hours @ 105C. For a conventional electrolytic capacitor the temperature acceleration coefficient = 2 for a 10C increase, while the OS-CON has a temperature acceleration coefficient = 10 for a 20C increase. For example, a capacitor rated for 2,000 hours @ 105C would have an expected life of:

- for conventional electrolytic capacitor
32,000 hours (3.6 years) @ 65C
128,000 hours (14.6 years) @ 45C
- for OS-CON capacitor
200,000 hours (22 years) @ 65C
2,000,000 hours (220 years) @ 45C

This means that the OS-CON has extremely longer life in practical use, even under the same warranty of 2,000 hours @ 105C.

In a buck converter, output ripple voltage is determined by both the inductor value, and the output filter capacitor (for continuous mode).

$$V_{p-p} = \frac{ESR * V_{out} * (1 - (\frac{V_{out}}{V_{in}}))}{L1 * frequency}$$

Note that only the ESR of the output capacitor is used in the formula. It is assumed that the capacitor is purely resistive at frequencies above 20kHz. Worst case output ripple is at highest input voltage. Ripple voltage is independent of load (for continuous mode).

Example

Vout = 5V, Vin = 28V, L1 = 55uH, frequency = 50kHz and three 330uF capacitor with 27mohm ESR in parallel.

$$V_{p-p} = \frac{0.009 * 5 * (1 - (\frac{5}{28}))}{55 * 10E6 * 0.5 * 10E5} = 14mV_{ripple}$$

3.6 Bus Termination (Optional)

“AC” bus termination is provided by 5 “RC” SOIC packages (3 only for 8-bit PC/104 bus HE104s), RC1 to RC5 and discrete components C20, C27. Each RC package contains 16 resistor/capacitor combinations of 47R and 47PF with a common bus connected to the signal ground.

	RC1	RC2	RC3	RC4	RC5
1	GND	GND	GND	GND	GND
2	*SMEMW	IRQ10	*BACK6	SA11	SA3
3	AEN	LA22	SD9	*REFRESH	BALE
4	IOCHRDY	IRQ11	DRQ6	SA12	SA4
5	SD0	LA21	*DACK7	DRQ1	IRQ3
6	SD1	LA20	SD11	SA13	SA5
7	SRDY	IRQ15	DRQ7	*DACK1	*DACK2
8	SD2	LA19	SD12	SA14	SA6
9	SD3	LA18	----	SA15	SA7
10	GND	GND	GND	GND	GND
11	GND	GND	GND	GND	GND
12	SD7	*MEMR	SD15	*IOW	IRQ6
13	SD6	LA17	SD14	SA17	SA9
14	SD5	LA18	SD13	*IOR	IRQ5
15	SD4	IRQ12	SD10	SA16	SA8
16	DRQ2	LA23	SD8	*DACK3	IRQ4
17	SA19	*IOCS16	DRQ5	DRQ3	DA2
18	*SMEMR	*SBHE	*MEMW	IRQ7	SA1
19	SA18	*MEMCS16	*DACK5	SA10	SA0
20	GND	GND	GND	GND	GND

In addition, the following signals are terminated with discrete components.

- TC C1 (330pF)
- Reset C20 (330pF)

APPENDIX A HE104, +5V Regulator Block Diagram

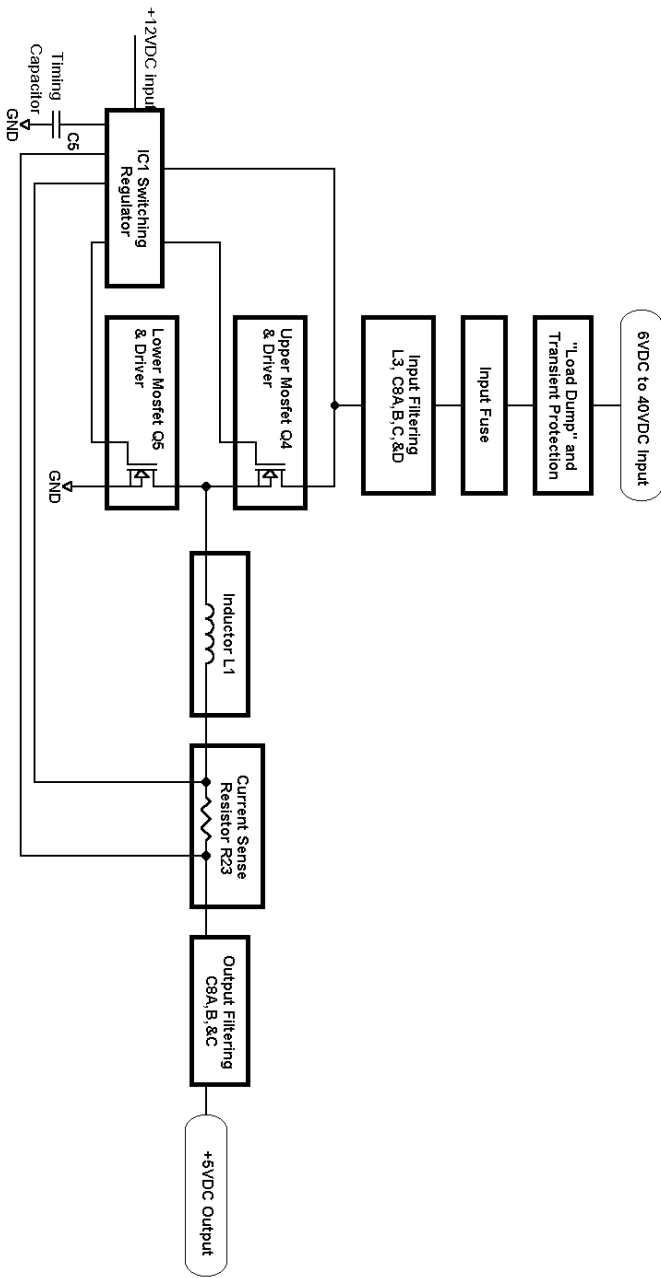

APPENDIX-1

APPENDIX B HE104, +12V, -12V, & -5V Regulator Block Diagram

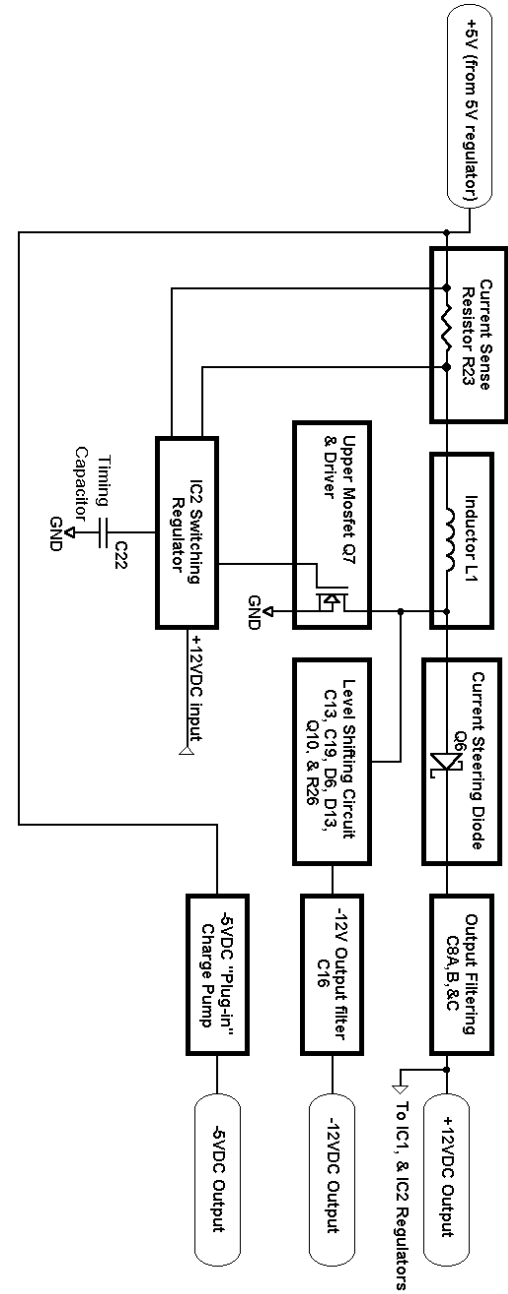

APPENDIX-2

APPENDIX C ADVANTAGES OF USING AC TERMINATION

One of the requirements of embedded electronics is for low power consumption. One method of reducing power is to reduce the drive current available to power the expansion bus. With over 80 signal lines, any reduction in current load would have a large impact on overall requirements. The PC/104 Consortium Guidelines for the expansion bus specify drive current can be as low as 4mA. Compared with the 24mA for the standard desktop computer, this is an 84 percent reduction in the drive current available.

The disadvantage to reducing drive current is the increasing possibility for noise to infiltrate the bus. The symptoms of noise induced problems are often "flaky" or unreliable operation. Systems suffering from noisy busses are often difficult to diagnose and solve. Programmers blame the hardware engineers, and the hardware engineers blame the software programmers.

With reduced drive currents, more attention must be paid to reducing the noise levels on the PC/104 bus. One frequently used method is bus terminators. Testing has proven the best way to terminate the PC/104 bus is to use AC terminators instead of resistive terminators. This is the recommended termination method for Ampro CPU products. The IEEE P996 PC Bus Standard recommends the AC bus terminating technique.

The use of AC terminators has several advantages over DC terminators:

- **Reduced power consumption:** DC terminators are typically in the 330 ohm to 1K ohm range and draw heavy currents. This is significant when terminating the over 80 signals on the PC/104 bus. AC terminators draw current only during the few nanoseconds when the bus signal is changing state, resulting in negligible current drain.
- **Improved bus reliability:** DC terminators invariably increase the voltage level of the logic zero state. This decreases noise immunity, making it more likely a zero will be seen as a one. AC terminators do not cause this shift, resulting in a more reliable bus.
- **Reduced crosstalk:** AC terminators roll off the signal transitions on the bus. The result is a quieter bus which has fewer high frequency effects such as crosstalk to other bus lines.
- **Reduced EMI.** Busses with AC termination tend to generate less EMI than resistively terminated buses due to the reduction in high frequency components of signal transitions.

APPENDIX D Installation Hints for the HE104 Power Supply

1. To minimize noise induced into the power supply, connect the HE104 power supply direct to the power supply source (battery) with "dedicated" wires. This makes use of the vehicle battery as a filter.
2. Always use large gauge hookup wires to connect the HE104 power supply the vehicle power source (battery). This minimizes any voltage drop caused by the resistance of the wire. Use minimum of AWG #16 for lengths less than 10 feet, and AWG #14 for longer lengths.
3. Where ever possible, install the HE104 power supply on to the "top" of the HE104 card stack. This will allow better dissipation of heat from the heat sink. If additional cooling is required, use either forced air ventilation, or mount the PC/104 power supply so that the heat sink can dissipate heat to the enclosure.

APPENDIX E Vehicles Are An Electronics Nightmare

Under the hood of a vehicle is an electronics nightmare. EMI spraying and RFI sparking is everywhere, and electrical transients run amuck, zapping the embedded electronics. Electronics located in that environment must withstand 600V transients, and load dump situations. Although the automotive market is growing about 2 percent yearly, the amount of electronics being introduced into vehicles is much higher. The electronics on a vehicle are no longer just the radio and engine computer, but cellular phones, portable computers and faxes, "smart" navigation with Global Positioning Receiver, and car alarm systems.

The infamous "load dump" is an energy surge resulting from disconnecting the battery while being charged. The alternator, with a finite response time of 40msec to 400msec, generates power with no where to go, thus an energy surge is formed, much like a tidal wave builds to an enormous height as it crashes the beach. The resultant overvoltage is the most formidable transient encountered in the automotive environment, and is an exponentially decaying positive voltage. The actual amplitude depends on alternator speed and the level of alternator field excitation, and can exceed 100V.

Each electronic component has its own power supply, and it is the power supplies that must absorb the transients and energy surges. What makes one transient more dangerous than another transient is not the voltage level, but the amount of energy in it. A 600V, 1msec transient has much less energy than a 100V, 400msec surge. Regardless of the source, all overvoltages must be clamped, and prevented from passing through to the rest of the electronics.

There are a number of methods for clamping overvoltages, but the most efficient and cost effective is to shunt the current to ground using a surge suppressor. The surge suppressor relies on the vehicle's wiring and alternator impedance as the current limit, and it remains in a high impedance state until an overvoltage condition occurs. Standard devices such as transorbs (P6KE or 1.5KE) will not

survive the high energy discharge of a load dump. Special "automotive" suppressors must be used to suck up the 20A to 30A peak currents being shunted. Several manufacturers, such as Motorola, Harris and Seimens, manufacture suppressors specifically for automotive applications. Some devices provide "zener diode" style protection, while others provide "back to back zener diode" bidirectional protection. Each type has advantages, but unless they are used correctly, they will fail to protect the electronics. Ratings on the transient suppressors can be confusing. A suppressor with an avalanche voltage of 24V to 32V will have a clamp off voltage of over 40V. In addition, ambient temperature can vary from -40C to 70C, and can result in the avalanche voltage being several volts lower, at -40C, and a clampoff serveral volts higher, at 70C.

Not all vehicles have 12V battery systems. Some trucks use 24V batteries, aircraft use 28V, and trains from 45V to 85V. Transient suppressors for aircraft cannot use the 12V system automotive components. Instead, a suppressor with an avalanche rating of 35V is needed to allow for low ambient temperature compensation, but this results in clamp off of over 70 volts. Tri-M Engineering's High Efficiency PC/104 Vehicle Power Supply, employs a Diode Inc. part#5KP43A, allowing an input voltage range of 6V to 40V. If a high clamp off voltage cannot be tolerated, other techniques must be used. A "series" device such as a MOSFET can act as a preregulator, but it also must be selected to withstand the transients. In addition a series device adds to in-efficiency, and creates a heat dissipation problem, especially at high ambients.

Load dumps occur infrequently in a vehicle's lifetime, but any electronics wishing to survive in this environment must be designed to withstand the assaults. Load dumps co-operate slightly though, their worst-case voltage does not typically occur with worst-case source impedence. In fact, although the total energy of a load dump may be 500 joules, a transient suppressor capable of 70 joules typically will be adequate because of the distributed electronics in the vehicle. That is, provided the suppressor ratings are the same or larger than other suppressors throughout the vehicle. The "quick thinking" engineer can take advantage of this, and design his power supply to withstand higher voltages, and thus let everyones elses transient suppressors do the work.

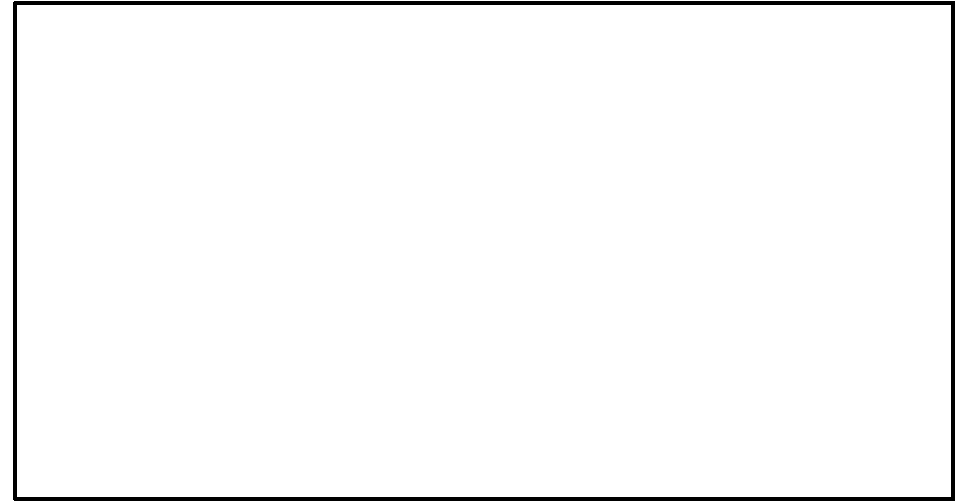

Distributed by:

*

